

2013

On the Recognition of Emotion from Physiological Data

Warren Creemers
Edith Cowan University

Follow this and additional works at: <https://ro.ecu.edu.au/theses>



Part of the [Artificial Intelligence and Robotics Commons](#)

Recommended Citation

Creemers, W. (2013). *On the Recognition of Emotion from Physiological Data*. <https://ro.ecu.edu.au/theses/680>

This Thesis is posted at Research Online.
<https://ro.ecu.edu.au/theses/680>

2013

On the Recognition of Emotion from Physiological Data

Warren Creemers
Edith Cowan University

Recommended Citation

Creemers, W. (2013). *On the Recognition of Emotion from Physiological Data*. Retrieved from <http://ro.ecu.edu.au/theses/680>

This Thesis is posted at Research Online.
<http://ro.ecu.edu.au/theses/680>

Edith Cowan University

Copyright Warning

You may print or download ONE copy of this document for the purpose of your own research or study.

The University does not authorize you to copy, communicate or otherwise make available electronically to any other person any copyright material contained on this site.

You are reminded of the following:

- Copyright owners are entitled to take legal action against persons who infringe their copyright.
- A reproduction of material that is protected by copyright may be a copyright infringement. Where the reproduction of such material is done without attribution of authorship, with false attribution of authorship or the authorship is treated in a derogatory manner, this may be a breach of the author's moral rights contained in Part IX of the Copyright Act 1968 (Cth).
- Courts have the power to impose a wide range of civil and criminal sanctions for infringement of copyright, infringement of moral rights and other offences under the Copyright Act 1968 (Cth). Higher penalties may apply, and higher damages may be awarded, for offences and infringements involving the conversion of material into digital or electronic form.

On the Recognition of Emotion from Physiological Data

A Thesis Submitted by Warren Creemers

In Partial Fulfillment of the Requirements for the award of
Doctor of Philosophy, (Computer Science)

At the
Faculty of Health, Engineering and Science
Edith Cowan University

February, 2013.

Abstract

This work encompasses several objectives, but is primarily concerned with an experiment where 33 participants were shown 32 slides in order to create ‘weakly induced emotions’. Recordings of the participants’ physiological state were taken as well as a self report of their emotional state. We then used an assortment of classifiers to predict emotional state from the recorded physiological signals, a process known as Physiological Pattern Recognition (PPR).

We investigated techniques for recording, processing and extracting features from six different physiological signals: Electrocardiogram (ECG), Blood Volume Pulse (BVP), Galvanic Skin Response (GSR), Electromyography (EMG), for the corrugator muscle, skin temperature for the finger and respiratory rate.

Improvements to the state of PPR emotion detection were made by allowing for 9 different weakly induced emotional states to be detected at nearly 65% accuracy. This is an improvement in the number of states readily detectable.

The work presents many investigations into numerical feature extraction from physiological signals and has a chapter dedicated to collating and trialing facial electromyography techniques. There is also a hardware device we created to collect participant self reported emotional states which showed several improvements to experimental procedure.

USE OF THESIS

The Use of Thesis statement is not included in this version of the thesis.

DECLARATION

I certify that this thesis does not incorporate without acknowledgment any material previously submitted for a degree or diploma in any institution of higher education; and that to the best of my knowledge and belief it does not contain any material previously written by another person except where due reference is made in the text.

Signature



Date 13/3/2013

ACKNOWLEDGMENTS

I would like to thank the participants and nurses who volunteered their time to make this research effort possible. I would also like to thank my supervisors for their enthusiastic support in this work. A special thanks to my other half, Liz, for her patience and free proof-reading service. Thanks are also due to our schools research support team who helped put the lab together and help construct specialised hardware. These acknowledgements cannot be complete without thanking my school for their faith in this project and the funding granted to purchase the recording hardware used extensively in this work.

Table of Contents

ABSTRACT	3
TABLE OF CONTENTS	7
INDEX OF FIGURES.....	16
1.0 INTRODUCTION.....	37
2.0 BACKGROUND.....	47
2.1 WHAT ARE EMOTIONS?	48
2.1.1. THE JAMES-LANGE THEORY	49
2.1.2. THE CANNON-BARD THEORY.....	50
2.1.3. THE TWO FACTOR THEORY	50
2.2 CULTURALLY SPECIFIC EMOTIONS	51
2.3 EMOTIONS FROM A RESEARCH PERSPECTIVE	52
2.3.1. EMOTION ORGANISATION THEORIES.....	53
2.3.2. HIERARCHICAL EMOTION CLASSIFICATION THEORIES	56
2.3.3. MIXED EMOTION CLASSIFICATION THEORIES.....	57
2.3.4. DIMENSIONAL EMOTION CLASSIFICATION THEORIES	58
2.3.5. FUZZY EMOTION CLASSIFICATION THEORIES	60
2.3.6. CONCLUSION	60
2.4 OVERVIEW OF CLASSIFICATION TECHNIQUES RELEVANT TO PPR.....	60
2.4.1. ASSESSING THE PERFORMANCE OF A CLASSIFIER	61
2.4.2. OVERVIEW OF THE K-NN CLASSIFIER	65
2.4.3. OVERVIEW OF ARTIFICIAL NEURAL NETWORK CLASSIFIERS	67
2.4.4. OVERVIEW OF THE SUPPORT VECTOR MACHINE CLASSIFIER.....	70
2.4.5. OVERVIEW OF THE NAIVE BAYES CLASSIFIER	72
2.4.6. OVERVIEW OF THE DECISION TREE CLASSIFIER	73
2.4.7. OVERVIEW OF THE RANDOM FOREST CLASSIFIER	75
2.5 OVERVIEW OF TECHNIQUES RELATED TO CLASSIFIERS	76
2.5.1. OVERVIEW OF THE FORWARD FEATURE SELECTION ALGORITHM.....	76
2.5.2. OVERVIEW OF N-FOLD CROSS VALIDATION	77
2.6 CONCLUSION	77

3.0	<u>A REVIEW OF CURRENT LITERATURE</u>	79
3.1	RECOGNITION OF EMOTION.....	81
3.2	CULTURALLY SPECIFIC EMOTIONS AND THE PLAUSIBILITY OF HETEROGENEOUS PHYSIOLOGICAL PATTERN RECOGNITION.....	83
3.3	PHYSIOLOGICAL CHANGES AS CUES FOR RECOGNITION OF EMOTION	86
3.3.1.	PHYSIOLOGICAL PATTERN RECOGNITION	88
3.3.2.	AN INVESTIGATION OF PHYSIOLOGICAL SIGNALS	90
3.3.3.	EXAMINING AND MONITORING THE PHYSIOLOGICAL STATE.....	91
3.3.4.	MUSCULAR PHYSIOLOGICAL SIGNALS (EMG) OF THE BACK (POSTURE & SUPPORT) 92	
3.3.5.	HUMAN ACTION OF THE HAND (PRESSURE).....	93
3.3.6.	HUMAN ACTION OF THE TORSO (POSTURE).....	94
3.3.7.	HUMAN AUTONOMOUS FUNCTIONS CONTROLLED BY THE MEDULLA OBLONGATA AND THE AUTONOMIC NERVOUS SYSTEM - OVERVIEW.....	94
3.3.8.	SIGNALS CONTROLLED BY THE MEDULLA OBLONGATA - RESPIRATION.....	97
3.3.9.	SIGNALS CONTROLLED BY THE MEDULLA OBLONGATA- HEART BEAT.....	98
3.3.10.	SIGNALS CONTROLLED BY THE MEDULLA OBLONGATA - BLOOD VOLUME PULSE 101	
3.3.11.	HUMAN AUTONOMOUS FUNCTIONS CONTROLLED BY THE MEDULLA OBLONGATA - BLOOD PRESSURE.....	102
3.3.12.	HUMAN DERMATOLOGICAL RESPONSE (SWEAT & SKIN CONDUCTANCE).....	103
3.3.13.	HUMAN THERMOREGULATORY RESPONSE - SKIN TEMPERATURE AND THE INSULA CORTEX	104
3.3.14.	SAMPLING OF SKIN TEMPERATURE FROM THE HAND	105
3.3.15.	SKIN TEMPERATURE AND ENVIRONMENTAL FACTORS.....	107
3.3.16.	HUMAN ACTION OF THE EYE.....	108
3.3.17.	SUMMARY OF PHYSIOLOGICAL CHANGES	110
3.4	OTHER FACTORS AFFECTING PHYSIOLOGICAL SIGNALS.....	111
3.4.1.	COMMON DRUGS IN RELATION TO PHYSIOLOGICAL SIGNALS.....	111
3.5	HUMAN EMOTION AS AN EXPERIMENTAL VARIABLE	112
3.5.1.	INFLUENCING THE HUMAN EMOTIONAL STATE.....	114
3.5.2.	OBSERVING EMOTION.....	117
3.6	HUMAN EMOTION IN HUMAN COMPUTER INTERACTION VS. HUMAN EMOTION IN RESEARCH	120
3.7	SUMMARY OF PHYSIOLOGICAL PATTERN RECOGNITION RESEARCH AND EXPERIMENTS.....	121

3.8 CONCLUSION	128
-----------------------------	------------

4.0 THE HUMAN FACE AND ITS COUPLING WITH THE EMOTIONAL STATE

129

4.1 BACKGROUND OF FACIAL EXPRESSION IN RELATION TO EMOTIONS	131
--	------------

4.1.1. EMOTIONAL VS. CONSCIOUS FACIAL MUSCLE ACTIVATION	133
---	-----

4.1.2. FACIAL DISPLAY RULES AND MICRO EXPRESSIONS	133
---	-----

4.1.3. FACIAL FEEDBACK THEORY AND ITS IMPLICATIONS FOR EMOTION RESEARCH	135
---	-----

4.1.4. OUR GUIDELINES FOR EXPERIMENTAL APPARATUS IN AFFECTIVE FACIAL STUDIES	140
--	-----

4.2 FACIAL EMG AS A METHOD OF STUDYING EMOTIONAL STATE.....	142
--	------------

4.3 PHYSIOLOGICAL SIGNALS (EMG) OF THE JAW.....	142
--	------------

4.3.1. ORBICULARIS ORIS	143
-------------------------------	-----

4.3.2. LEVATOR ANGULI ORIS (CANINUS)	145
--	-----

4.3.3. LEVATOR LABII SUPERIORIS (OR QUADRATUS LABII SUPERIORIS)	146
---	-----

4.3.4. ZYGOMATICUS MINOR	148
--------------------------------	-----

4.3.5. ZYGOMATICUS MAJOR	149
--------------------------------	-----

4.3.6. RISORIIUS.....	153
-----------------------	-----

4.3.7. BUCCINATOR	154
-------------------------	-----

4.3.8. QUADRATUS LABII INFERIORIS (DEPRESSOR LABII INFERIORIS)	155
--	-----

4.3.9. DEPRESSOR ANGULI ORIS (TRIANGULARIS)	157
---	-----

4.3.10. MENTALIS	158
------------------------	-----

4.3.11. RISORIIUS.....	159
------------------------	-----

4.3.12. PLATYSMA	160
------------------------	-----

4.4 PHYSIOLOGICAL SIGNALS (EMG) OF THE EYES	161
--	------------

4.4.1. FRONTALIS.....	163
-----------------------	-----

4.4.2. CORRUGATOR SUPERCILII	165
------------------------------------	-----

4.4.3. ORBICULARIS OCULI	169
--------------------------------	-----

4.4.4. PROCERUS.....	173
----------------------	-----

4.5 PHYSIOLOGICAL SIGNALS (EMG) OF THE NOSE.....	174
---	------------

4.5.1. NASALIS TRANSVERSA	174
---------------------------------	-----

4.5.2. NASALIS ALARIS.....	175
----------------------------	-----

4.6 SUMMARY OF THE AFFECTIVE CAPACITY OF THE MIMETIC MUSCLES	176
---	------------

5.0 EXAMINATION OF ELECTROMYOGRAPHY RESULTS FROM POSED

<u>FACIAL EXPRESSIONS.....</u>	<u>179</u>
---------------------------------------	-------------------

5.1	EMG OF THE ORBICULARIS ORIS.....	181
5.2	EMG OF THE ZYGOMATICUS MAJOR.....	183
5.3	EMG OF THE BUCCINATOR.....	185
5.4	EMG OF THE DEPRESSOR ANGULI ORIS.....	187
5.5	EMG OF THE MENTALIS.....	189
5.6	EMG OF THE ORBICULARIS OCULI.....	191
5.7	EMG OF THE FRONTALIS	193
5.8	EMG OF THE CORRUGATOR SUPERCILII.....	195
5.9	EMG OF THE SUPRAHYOID PLACEMENT	198
5.10	EMG OF THE TEMPORAL SUPRAHYOID PLACEMENT	203
5.11	EMG OF THE TEMPORAL MASSETER (WIDE) PLACEMENT.....	207
5.12	EMG OF THE FRONTAL (WIDE) PLACEMENT.....	210
5.13	CONCLUSION	213
6.0	<u>EXPERIMENTAL DESIGN</u>	<u>215</u>
6.1	SYNOPSIS.....	217
6.2	DATA COLLECTED	218
6.3	DESIGN.....	219
6.4	DISCRIMINANT VALIDITY OF EMOTIONS INDUCED	221
6.5	VALIDITY OF EMOTIONS REPORTED	227
6.6	VALIDITY OF SOMATOVISCERAL RESPONSES OBSERVED.....	228
6.7	PARTICIPANTS	228
6.8	CONCLUSION	229
7.0	<u>METHOD AND MATERIALS.....</u>	<u>233</u>
7.1	TUTORIAL SLIDES	235
7.1.1.	FEEDBACK INSTRUCTION.....	237
7.1.2.	SIMULATED CRASH.....	238
7.2	ROOM SETUP	239
7.2.1.	AFFECTIVE TONE.....	240
7.2.2.	LIGHTING	241
7.2.3.	LOCATION.....	242
7.2.4.	TECHNICAL REQUIREMENTS.....	243
7.2.5.	OUR EXPERIMENTATION WITH A SHIELD ROOM TO ELIMINATE RF INTERFERENCE	244
7.2.6.	OUR GUIDELINE FOR ROOM PREPARATION (A SUMMARY).....	245

7.3 PROCEDURES FOR INTERACTION WITH PARTICIPANTS	246
7.3.1. PRIVACY FOR HONESTY OF FEEDBACK	246
7.3.2. RECRUITMENT AND PRE-EXPERIMENT CONTACT.....	247
7.3.3. ENTRANCE PROCEDURE.....	247
7.3.4. EXIT PROCEDURE.....	249
7.3.5. ETHICAL TREATMENT OF HUMANS	250
7.4 SAFETY.....	250
7.4.1. ELECTRODE ISOLATION	251
7.4.2. ELECTRICAL AND BIOHAZARD SAFETY REQUIREMENTS (AS3200 & IEC6060-1) ..	252
7.4.3. BIOLOGICAL HAZARDS	253
7.4.4. POSSIBLE ALLERGENS	254
7.5 EQUIPMENT CAPABILITIES AND APPLICATION.....	254
7.5.1. ENCODER	254
7.5.2. THE EMG SENSOR.....	255
7.5.3. THE ECG SENSOR.....	257
7.5.4. THE BVP SENSOR.....	258
7.5.5. THE GSR SENSOR.....	258
7.5.6. THE TEMPERATURE SENSOR.....	260
7.5.7. THE RESPIRATION SENSOR	260
7.6 SOFTWARE.....	261
7.7 CONCLUSION	263
<u>8.0 FEEDBACK VIA A HARDWARE SAM IMPLEMENTATION.....</u>	<u>265</u>
8.1 REQUIREMENTS ANALYSIS.....	268
8.2 SAM ON PRINTED ANSWER SHEETS	270
8.3 SAM AS PC SOFTWARE	271
8.4 SAM ON A PERSONAL DIGITAL ASSISTANT (PDA/TABLET)	276
8.5 SAM AS A CUSTOMISED HARDWARE DEVICE.....	280
8.5.1. USER INTERFACE	280
8.5.2. TECHNICAL CAPABILITIES	281
8.5.3. SIGNAL QUALITY	282
8.5.4. TECHNICAL CHALLENGES	283
8.6 CONCLUSION	284
<u>9.0 SIGNAL PROCESSING AND FEATURE EXTRACTION.....</u>	<u>287</u>

9.1 ECG SIGNAL.....	289
9.1.1. OVERVIEW OF FILTERING THE ECG SIGNAL	289
9.1.2. EMG AND POWER LINE NOISE REMOVAL.....	294
9.1.3. ARTEFACT DETECTION	308
9.1.4. BASELINE DRIFT CORRECTION VIA MEDIAN FILTERING	308
9.1.5. OVERVIEW OF FEATURE DETECTION IN THE ECG SIGNAL	311
9.1.6. WAVELET DECOMPOSITION AND AUTOMATED ECG ANNOTATION	313
9.1.7. EXTRACTION OF TRAINING DATA FROM THE ECG	315
9.1.8. INVARIANT FEATURE SELECTION FROM THE ECG.....	316
9.1.9. SUMMARY OF ECG PROCESSING AND FEATURE EXTRACTION	319
9.2 EMG SIGNAL.....	319
9.2.1. EMG FEATURE EXTRACTION	320
9.2.2. ARTEFACT DETECTION	342
9.3 SKIN TEMPERATURE	343
9.3.1. SKIN TEMPERATURE ALTERATION BY MOOD AND MEDIUM TERM TRENDS	345
9.3.2. A SKIN TEMPERATURE FEATURE EXTRACTION METHOD.....	348
9.4 RESPIRATION.....	349
9.5 BLOOD VOLUME PULSE.....	352
9.5.1. FEATURES EXTRACTED	354
9.6 GALVANIC SKIN RESPONSE	355
9.7 SAMPLING OF TIME SERIES DATA	357
9.8 SUMMARY	359
<u>10.0 ANALYSIS OF COLLECTED DATA</u>	<u>361</u>
10.1 LABELLING OF DATA FOR CLASSIFICATION AND ANALYSIS	363
10.1.1. FINDING A GOOD DEAD-ZONE FOR THE GRID DIVISION OF EMOTIONAL STATES .	365
10.1.2. APPLYING K-MEANS CLUSTERING TO THE SAM RATINGS	366
10.2 NAMES USED FOR DESCRIBING FEATURES	370
10.3 EXTERNAL FACTORS IN RECORDED PHYSIOLOGICAL DATA	372
10.3.1. PARTICIPANT MOOD PRIOR TO THE EXPERIMENT	373
10.3.2. DIURNAL AUTONOMIC VARIATIONS	373
10.4 EFFECTIVENESS OF THE IAPS STIMULI	377
10.4.1. EXAMPLE OF CULTURAL BIAS IN AUSTRALIAN RESPONDENTS: SNAKE FEAR IS LESS PREVALENT.....	381
10.4.2. EXAMPLE OF CULTURAL BIAS IN AUSTRALIAN RESPONDENTS: A BOY WITH HIS HEAD IN A BISON'S ARSE IS JUST NOT INTERESTING	382

10.5	PARTICIPANT SELF ASSESSMENT RESPONSES	384
10.5.1.	SUMMARY OF EFFECTIVENESS OF STIMULI	388
10.6	VISUALISING RESULTS OBTAINED FROM PHYSIOLOGICAL RECORDINGS.....	389
10.6.1.	VISUALISING THE ROLE OF RESPIRATION	390
10.6.2.	VISUALISING EMG CORRELATIONS.....	392
10.6.3.	VISUALISING THE DIFFICULTIES OF HETEROGENEOUS CLASSIFICATION TASKS ...	393
10.6.4.	VISUALISING TIME AS A FACTOR IN OBSCURING EMOTIONAL RESPONSE.....	394
10.7	VISUALISING THE FEASIBILITY OF USING MULTIVARIATE DATA TO SEPARATE HETEROGENEOUS RESULTS SETS	395
10.8	SAMPLING OF DATA FOR CLASSIFICATION	396
10.9	A FEATURE SELECTION INVESTIGATION	396
10.10	CONCLUSION	403
<u>11.0</u>	<u>CLASSIFICATION OF DATA.....</u>	<u>405</u>
11.1	WHICH FEATURES SHOULD BE USED?.....	407
11.2	HOW DOES THE PERFORMANCE OF CLASSIFIERS VARY FOR OUR DIFFERENT TYPES OF CLASS LABELS?	411
11.3	NAIVE BAYES CLASSIFIER.....	413
11.4	THE RANDOM FOREST CLASSIFIER.....	417
11.5	THE NEURAL NETWORK CLASSIFIER.....	423
11.5.1.	BASIC TUNING OF THE ANN CLASSIFIER, NUMBER OF LAYERS AND TRAINING EPOCHS	423
11.5.2.	FURTHER TUNING OF THE ANN, MOMENTUM AND LEARNING RATE.....	427
11.5.3.	ANN PERFORMANCE OVERVIEW	429
11.6	K-NN CLASSIFIER	432
11.7	SUPPORT VECTOR MACHINE CLASSIFIER.....	438
11.7.1.	LINEAR KERNEL	439
11.7.2.	POLYNOMIAL KERNEL.....	440
11.7.3.	RADIAL BASIS FUNCTION (RBF) KERNEL.....	441
11.7.4.	SIGMOID KERNEL	441
11.7.5.	COMPARISON OF SVM KERNELS	444
11.8	SELECTING THE BEST CLASSIFIER	447
11.9	CONCLUSION	448
11.9.1.	COMPARISON WITH OTHER WORKS.....	450
<u>12.0</u>	<u>CONCLUSION.....</u>	<u>451</u>

12.1	CONTRIBUTIONS.....	453
12.1.1.	REVIEW OF PHYSIOLOGICAL & NEUROLOGICAL PROCESSES OF EMOTION	453
12.1.2.	FACIAL MUSCLES	454
12.1.3.	SAM	454
12.1.4.	STIMULUS SELECTION	455
12.1.5.	SIGNAL PROCESSING	456
12.1.6.	FEATURE EXTRACTION	457
12.1.7.	LABELLING EMOTIONS	458
12.1.8.	CLASSIFICATION PERFORMANCE.....	459
12.2	FUTURE WORK AND FINAL THOUGHTS.....	460
13.0	<u>GLOSSARY</u>	<u>463</u>
14.0	<u>APPENDIX</u>	<u>469</u>
14.1	STIMULUS SLIDES.....	470
14.2	SAM EVALUATIONS USER RELIABILITY CHARTS.....	473
14.3	IAPS SLIDE SCATTER PLOTS	485
14.4	ECG “NARF” COMPENSATIONS FOR ALL INTERVALS OF THE TYPICAL WAVEFORM.....	504
14.5	IMPLEMENTATIONS OF SELECTED ALGORITHMS.....	510
14.5.1.	LINEAR CRITERION FOR ECG SUBTRACTION PROCEDURE.	510
14.6	ASSORTED NOTICES AND COMMUNICATIONS USED.....	512
14.7	RISK MANAGEMENT REPORT	518
14.8	EMAIL SENT TO ALL WOULD BE VOLUNTEERS	525
14.9	MEDIAN FILTERING ALGORITHM.....	527
14.10	HARDWARE SAM CIRCUIT DIAGRAM AND INFORMATION.....	531
14.10.1.	MICROCONTROLLER	532
14.10.2.	POWER SUPPLY	532
14.10.3.	AUDIO TONE OUTPUT.....	533
14.10.4.	MICROPHONE OUTPUT.....	533
14.10.5.	SYNCH OUTPUT	533
14.10.6.	SAM LED OUTPUTS.....	534
14.10.7.	READING INPUT VOLTAGES.....	534
14.10.8.	CONVERSION TIME	535
14.10.9.	READING SAM SELECTION SWITCHES	536
14.10.10.	RESISTOR LADDER VALUES	537

14.10.11.	DETERMINATION OF RANGE.....	538
14.10.12.	SAM SWITCH DURATION	540
14.10.13.	COMMUNICATIONS	541
14.10.14.	PROTOCOL	541
14.10.15.	COMMAND SET	542
14.10.16.	OUTPUT COMMANDS	542
14.10.17.	INPUT COMMANDS.....	543
15.0	<u>REFERENCES</u>	<u>545</u>

Index of Figures

Figure 1 : Emotion theory heirarchy	53
Figure 2: Plutchik's wheel of emotions	57
Figure 3: Semantic Differential, showing two peoples ratings for “policemen” (Pagon, 1996).	58
Figure 4: The circumplex model of emotion. Russell (Russell, 1980) plotted different emotions on a two dimensional space created by two axes, arousal and Valence. These axes of Arousal and Valence can have both positive , neutral and negative values.	59
Figure 5: Operation of a working classifier	61
Figure 6: Examples of Classifier Boundaries in Feature Space. A) Is an ideal. B) Shows a poor fit. C) Shows an over-fit. D) Show a data item that cannot be fitted.	63
Figure 7: Sensitivity and Specificity Shown Graphically. A) High Specificity; B) Low specificity; C) High Sensitivity; D) Low Sensitivity.	64
Figure 8: Example of k-NN on a 2 dimensional dataset.	66
Figure 9: ANN setup with one hidden layer	68
Figure 10: Typical ANN setup for classification	69
Figure 11: Support vector machine setup	70
Figure 12: Allowing for better separation of training points by projecting the data (part A, in 1 dimension) into a higher dimensional space (part B, in 2 dimensions). The hyper plane is shown in black.	71
Figure 13: A Trivial Decision Tree Example	73
Figure 14: Physiological (blue) and Cognitive (red) signals.	82
Figure 15: Depiction of schadenfreude, in the Simpsons character Nelson Muntz (Groening & Brooks, 2006)	85
Figure 16: Dimensional projection via a day dependence matrix (Picard, Vyzas, & Healey, 2001)	88
Figure 17: Structures of the brain involved in emotion.	91
Figure 18: Variables Affecting the Physiological State	92
Figure 19: The "TouchPhone"	94
Figure 20: The Structure of the Autonomic Nervous System (Lane et al., 2009)	96
Figure 21: Respiration Cycle	97
Figure 22: Wiggers Diagram, (Guyton, 2000) ; Chapter 9 - Page 99.	99

Figure 23: Heart Rate in Relation to Pleasant Emotions (Libby Jr et al., 1973)	100
Figure 24: Heart rate response to various slide types	100
Figure 25: Heart rate in response to negative animal stimuli, in phobic and non phobic participants. (Globisch et al., 1999)	101
Figure 26: A BVP Envelope (Fernandez & Picard, 1998).....	102
Figure 27: Blood Pressure in response to negative animal stimuli, in phobic and non phobic participants. (Globisch et al., 1999)	102
Figure 28: Skin Conductance in response to negative animal stimuli, in phobic and non phobic participants. (Globisch et al., 1999)	104
Figure 29: Medical conditions effecting skin temperature of the hands.....	106
Figure 30: 4 Hand-temperature types identified by Kokubo et al., Dark regions indicate thermal hot spots of the four hand circulation types. Corresponding mean hand temperatures and deviations given above.	107
Figure 31: Averaged pupil diameter timelines for the different stimulus categories for female (above) and male (below). (Partala & Surakka, 2003)	109
Figure 32: Mean changes in systolic blood pressure (SBP; A), diastolic blood pressure (DBP; B), mean arterial pressure (MAP; C), and heart rate (D) in response to ingestion of 6 mg/kg caffeine during rest and 65% maximal oxygen consumption. bpm, Beats/min. ◻, Rest-placebo; •, rest-caffeine; (Daniels et al., 1998).....	112
Figure 33: Self Assessment Manikin.	118
Figure 34: PrEmo Self Report Device by Desmet	119
Figure 35: PrEmo Animations	119
Figure 36: User thoughts in HCI mapped onto emotional dominance.	121
Figure 37: The Sentograph (Clynes, 1978). A two-dimensional touch transducer for biocybernetic measurements of finger pressure.....	122
Figure 38: Confusion matrices for training performed Nasoz et al., (Nasoz et al., 2003). MBG Marquardt back-propagation algorithm trained ANN; KNN k-Nearest Neighbour Algorithm; DFA Discriminant Function Analysis.....	123
Figure 39: Summary of PPR Research into Emotion Classification. EMG Electromyography; BVP Blood Volume Pulse; GSR Galvanic Skin Response; RS Respiration; ST Skin Temperature; HR Heart Rate; ECG Electrocardiogram; BI bio-impedance; HS heart sounds; PD Pupil Diameter; EDA blood-glucose levels; SFS Sequential Backward Selection; Fisher Fisher Projection; LDA Linear Discriminant Analysis; HMM Hidden Markov Model; kNN k Nearest Neighbour; MLP Multilayer	

Perceptron; DBI Davies-Bouldin Index; ANOVA Analysis of Variance; BN Bayesian Network; RT Regression Tree; AANN Auto-Associative Neural Network; ANN artificial neural network; ANFIS Adaptive Neuro-Fuzzy Inference System; EMDC Emotion-specific Multilevel Dichotomous Classification; SVM Support Vector Machine; DFA Discriminant Function Analysis; MBP Marquardt Back Propagation.	127
Figure 40: Photographs of Duchenne Experiments (Duchenne, 1876)	131
Figure 41: Modulation of facial expression to produce an apparent emotion in line with social display rules.....	134
Figure 42: Basic premise of facial feedback.....	135
Figure 43: Lips, teeth and alternate teeth conditions for holding a pen.....	136
Figure 44: A) Wider view of facial feedback in relation to emotion as compared to, B) classical thoughts on facial expression.	137
Figure 45: the vascular theory of emotion	138
Figure 46: Results obtained by Davis et. al., showing the effects of Botox and Restylane (the placebo) in processing emotional stimuli.	139
Figure 47: Venn diagram of selected emotional theories	141
Figure 48: Location of the Orbicularis Oris.....	143
Figure 49: Actions of the Orbicularis Oris	144
Figure 50: Location of the Caninus	145
Figure 51: Actions of the Caninus	145
Figure 52: Location of the Levator Labii Superioris.	146
Figure 53: Actions of the Levator Labii Superioris	146
Figure 54: EMG change from baseline and standard errors in response to emotional imagery.	147
Figure 55: Location of the Zygomaticus Minor.....	148
Figure 56: Actions of the Zygomaticus Minor.	148
Figure 57: Location of the Zygomaticus Major.....	149
Figure 58: Actions of the Zygomaticus Major.....	150
Figure 59: Facial expression of a Smile (A) posed (b) spontaneous (Schmidt et al., 2006)	150
Figure 60: Mean Zygomaticus Major EMG Responses to Happy and Angry Facial Animations. (Achaibou et al., 2008).....	152

Figure 61: EMG change from baseline and standard errors in response to emotional imagery.	153
Figure 62: Location of the Risorius.	153
Figure 63: Actions of the Risorius.	154
Figure 64: Location of the Buccinator.	154
Figure 65: Actions of the buccinator.	155
Figure 66: Location of the Quadratus Labii Inferioris.	156
Figure 67: Actions of the Quadratus Labii Inferioris.	156
Figure 68: Location of the Depressor Anguli Oris.	157
Figure 69: Actions of the Depressor Anguli Oris.	157
Figure 70: Location of the Mentalis.	158
Figure 71: Actions of the Mentalis.	159
Figure 72: Location of the Risorius.	159
Figure 73: Actions of the Risorius.	160
Figure 74: Location of the Platysma.	160
Figure 75: Actions of the Platysma.	161
Figure 76: The primary motor strip of the cerebral cortex (Penfield & Rasmussen, 1950). The relative proportion of cortical tissue controlling the muscles of the body is illustrated by the cartoon; and more precisely by the length of the dark lines. Note the size of the mouth in proportion to the rest of the face.	162
Figure 77: Location of the Frontalis	163
Figure 78: Actions of the Frontalis	164
Figure 79: "Expression Glasses" (Scheirer et al., 1999)	164
Figure 80: Location of the Corrugator Supercilii	165
Figure 81: Actions of the Corrugator Supercilii	165
Figure 82: EMG activity(mean) for angry and happy faces. (Hess, Philippot & Blairy, 1998)	166
Figure 83: EMG responses to happy and angry facial animations (Achaibou et al., 2008)	167
Figure 84: EMG Reactions to Assorted Stimulus (J. T. Cacioppo et al., 1992),. The Corrugator Supercilii shows higher activity for negative stimuli and lower for positive stimuli.	168
Figure 85: EMG change from baseline and standard errors in response to emotional imagery.	168

Figure 86: Location of the Orbicularis Oculi.....	169
Figure 87: Actions of the Orbicularis Oculi.	170
Figure 88: EMG Reactions to Assorted Stimulus (J. T. Cacioppo et al., 1992),. The Orbicularis Oculi displays higher EMG activity when a participant was shown pleasant Stimuli, while the Corrugator Supercilii shows higher activity for negative stimuli.	171
Figure 89: Orbicularis Oculi EMG activity (mean) for angry and happy stimulus. (Ursula et al., 1998)	171
Figure 90: Excerpt from (Willibald & Ekman, 2001) with the Orbicularis Oculi and Corrugator Supercilii related text highlighted.	172
Figure 91: Location of the Procerus.....	173
Figure 92: Actions of the Procerus.	173
Figure 93: Location of the Nasalis Transversa.	174
Figure 94: Actions of the Nasalis Transversa.	175
Figure 95: Location of the Nasalis Alaris.	175
Figure 96: Actions of the Nasalis Alaris.....	176
Figure 97: Orbicularis Oris Electrode Placement.	181
Figure 98: Typical EMG Recording for the Orbicularis Oris showing (A) a pursed smile with the lips closed. (B) A pensive biting of the lip. (C) Talking.....	182
Figure 99: Zygomaticus Major Electrode Placement.	183
Figure 100: Zygomaticus Major EMG recordings showing smiling and talking.	184
Figure 101: Buccinator Electrode Placement.	185
Figure 102: Buccinator EMG recordings showing: (A) blowing air through the lips in expressions of exasperation and self control. (B) Smiling. (C) Lips pursed in and expression of contemplative contraction.	186
Figure 103: Depressor Anguli Oris Electrode Placement.....	187
Figure 104: A typical Depressor Anguli Oris EMG recording showing: Frowning, (B) Showing scorn, (C) Talking.....	188
Figure 105: Mentalis Electrode Placement.	189
Figure 106: EMG testing of the Mentalis showing typical results for actions of grimacing, showing doubt, frowning and talking.	190
Figure 107: Orbicularis Oculi Electrode Placement.	191
Figure 108: Typical EMG recordings for the Orbicularis Oculi showing the actions of blinking, squinting and smiling.....	192

Figure 109: Frontalis Electrode Placement.....	193
Figure 110: Typical EMG recordings for the Frontalis showing posed expressions of anger, surprise and sadness.	194
Figure 111: Corrugator Supercilii Electrode Placement.....	195
Figure 112: Typical EMG recordings for the Corrugator Supercilii showing expressions of frowning, pain, desperation and effort.	196
Figure 113: EMG of the Corrugator Supercilii showing blink artefact.	197
Figure 114: Suprahyoid Placement.	198
Figure 115: Typical EMG recordings for the Suprahyoid Placement. Participant Clenched their teeth four times.	199
Figure 116: Typical EMG recordings for the Suprahyoid Placement. Two frowns are shown. Note: The first frown was less intense.	199
Figure 117: Typical EMG recordings for the Suprahyoid Placement. The recording is of genuine laughter that was invoked by the telling of a joke.	200
Figure 118: Typical EMG recordings for the Suprahyoid Placement. The participant was instructed to please stop laughing at a previous joke. The face returns to a visibly neutral position, but the suppressed laughter was still detected.	200
Figure 119: Typical EMG recordings for the Suprahyoid Placement. Jaw was opened and closed several times. The feature after the 30 second mark is unrelated.	201
Figure 120: Typical EMG recordings for the Suprahyoid Placement. The participant spontaneously yawned.	201
Figure 121: Typical EMG recordings for the Suprahyoid Placement. (Displaying a (genuine) sigh of relief after a long recording session).	202
Figure 122: Temporal Suprahyoid Placement.	203
Figure 123: Typical EMG recordings for the Temporal Suprahyoid Placement showing the features created by frowning.	204
Figure 124: Typical EMG recordings for the Temporal Suprahyoid Placement showing smiling.	204
Figure 125: Typical EMG recordings for the Temporal Suprahyoid Placement showing four raises of the eyebrows.	205
Figure 126: Typical EMG recordings for the Temporal Suprahyoid Placement showing posed surprise.	205

Figure 127: Typical EMG recordings for the Temporal Suprahyoid Placement showing the features created by opening and closing the jaw. The last feature is the jaw closing.	206
Figure 128: Masseter (Wide) Placement.....	207
Figure 129: Typical EMG recordings for the Masseter (Wide) Placement showing clenching of the Jaw.....	208
Figure 130: Typical EMG recordings for the Masseter (Wide) Placement showing a single extension of the jaw.....	208
Figure 131: Typical EMG recordings for the Masseter (Wide) Placement showing genuine laughter in response to a joke.....	209
Figure 132: Typical EMG recordings for the Masseter (Wide) Placement, showing a genuine yawn.	209
Figure 133: Frontal (Wide) Electrode Placement.	210
Figure 134: Typical EMG recordings for the Frontal (Wide) Placement showing the action of frowning.....	211
Figure 135: Typical EMG recordings for the Frontal (Wide) Placement showing the action of clenching the jaw.	211
Figure 136: Typical EMG recordings for the Frontal (Wide) Placement showing the action raising the eyebrows three times.	212
Figure 137: Typical EMG recordings for the Frontal (Wide) Placement showing the action of swallowing.....	212
Figure 138: Self Assessment Manikin	219
Figure 139: Software for IAPS show optimisation.....	224
Figure 140: Overview of experiment procedure	234
Figure 141: Introductory slides.....	236
Figure 142: Feedback slide, displayed after each stimulus while the participant completes the self assessment task.	237
Figure 143: Crash screen (left) and crash rating screen (Right)	238
Figure 144: Experimental room, plan view.	240
Figure 145: The participant survey sheet, the annotation below was made without the participant's knowledge.	248
Figure 146: Final slide	249
Figure 147: An example opto-isolator circuit.....	251

Figure 148: Thought Technology T3404 three-strip Uni-Gel electrodes (unseparated)	256
Figure 149: Electrode placement for ECG electrodes.	258
Figure 150: Location of GSR placement.	260
Figure 151: Self Assessment Manikin.	266
Figure 152: The Hardware SAM developed for this experiment.	269
Figure 153: Noise in ECG Signal produced while using SAM on a hardware device.	270
Figure 154: A generic PC controlled SAM experiment.	271
Figure 155: PXLab software (Irtel, 2007).	272
Figure 156: Self Assessment Manikin Software [as used by (Choppin, 2000)].	273
Figure 157: Apple vs. IBM branding, effect on creativity (Fitzsimons, 2008). Results given for experiments conducted with and without a five minute delay between the priming stimulus and the creativity task.	274
Figure 158: Cluttered experimental setup. (Swindells et al., 2007).	275
Figure 159: Noise in ECG Signal produced while using PXLab. Shaded region indicates SAM was in use.	276
Fig 160: Our SAM implementation on a PDA	277
Figure 161: (Neerinx & Streefkerk, 2003) Measurement of user trust in a device both before and after a experimental task.	278
Figure 162 : Noise in ECG Signal produced while using SAM on a PDA (user is coached). Shaded region indicates SAM was in use.	278
Figure 163: Noise in ECG Signal produced while using SAM on a PDA (user is not coached). Shaded region indicates SAM was in use.	279
Figure 164 SAM character from: PDA (left), VGA (middle), paper (Right).	280
Figure 165: Hardware Sync Signal. First Sequence has 7 peaks, and the second sequence 9 peaks. Giving this recording the unique ID “79”.	281
Figure 166: Noise in ECG Signal produced while using SAM on a hardware device. Shaded region indicates SAM was in use.	282
Figure 167: Resistor Ladder used in the hardware SAM.	283
Figure 168: Comparison of SAM feedback Devices.	284
Figure 169 The Basic ECG waveform showing locations of the P, Q, R, S, T & U Components	289
Figure 170: Components of the ECG Spectrum (Thakor, 1988)	290

Figure 171: Examples of electrode motion artefacts in our experiment. (a) Electrode drop out followed by saturation of signal by EMG (muscle activity) noise. (b), rapid baseline drift.....	291
Figure 172: Baseline drift in the ECG signal.....	291
Figure 173: Device noise, A filtering artefact in response to impulse noise.	292
Figure 174: Electrode pop noise as recorded on day two of the experiment.	293
Figure 175: Sources of high frequency noise in the ECG signal.	294
Figure 176: Savitzky-Golay Filtering at Different Orders on Synthetic ECG data. Top left graph is the source signal and its noise components. Other graphs are the result of filtering the signal shown and comparing to the known synthetic data to visualise the error.....	295
Figure 177: Line noise artefacts (in red) after removing EMG jitter from signal using a Savitzky-Golay Finite impulse response filter. A sample 50Hz sine wave is shown below the ECG.....	297
Figure 178: Our results using the ECG noise subtraction procedure as described by (Levkov et al., 2005). The original signal is in black, the baseline and noise corrected version is in blue and the orange lines at the top indicate the linear criterion.	298
Figure 179: Demonstrates linear criterion (lower line) detection problems when EMG (upper line) noise is present. Notice the noise is decreasing as the signal progresses, resulting in increased linear criterion performance.	299
Figure 180: Wavelet processed ECG signal.	300
Figure 181: Synthetic ECG noise, 50hz (top), generated at 0.1, 0.2 or 0.3 mV, and EMG (bottom) present at a signal to noise ratio of 2, 5 or 10dB.....	302
Figure 182: Performance of Different Wavelets in EMG De-Noising (lower results are better).	303
Figure 183: Error level by EMG noise (lower error level results are better). Note: The noise is expressed as signal to noise ratio so lower values mean more noise.....	304
Figure 184: De-Noising Performance by decomposition level (across all wavelets)	304
Figure 185: Pseudo-Gibbs Artefact (Su & Zhao, 2005). Top graph is source signal, second graph is noisy version, third graph is the wavelet de-noised, showing only minimal pseudo-Gibbs artefacts near the Q and S portions of the ECG signal.	306
Figure 186: Multiple Wavelet De-noising Technique (above). Raw Signal (below) Average wavelet in red superimposed on 15 key wavelets (gray).....	307

Figure 187 An Extreme Instance of Baseline Drift. The baseline is detected using median filtering and is shown as the curved line running through the signal.....	310
Figure 188 Baseline corrected ECG signal.....	310
Figure 189: Typical ECG Signal - QRS Complex.....	311
Figure 190 Nomenclature of various possible QRS intervals.....	312
Figure 191: ECG Annotations Against Raw ECG signal.	315
Figure 192: EMG Thresh holding.....	320
Figure 193: Time vs. Frequency domain EMG features; The lower graph is a spectrogram and the colouring is a third dimension indicating the amplitude of the given frequency (x) for the given time (y).....	321
Figure 194: IEMG (window = 1s) feature extracted from experiment data. IEMG shown in red, EMG (not to scale) shown in black.....	324
Figure 195: IEMG by participant.....	324
Figure 196: MAV by participant.....	325
Figure 197: WMAV1 (MMAV) by participant	326
Figure 198: WMAV2 (MMAV2) by participant.....	327
Figure 199: MAVSLP by participant.....	328
Figure 200: SSI by participant.....	329
Figure 201: VAR by participant.....	330
Figure 202: RMS by participant.....	331
Figure 203: WL by participant.....	332
Figure 204: SSC by participant.....	333
Figure 205: WAMP by participant.....	334
Figure 206: : Distribution of autoregressive coefficients 1-10.....	336
Figure 207: EMG Power Spectrum for a participant in our experiment.....	337
Figure 208: Median Frequency Distribution (MDF), by participant	338
Figure 209: Mean Frequency Distribution (MNF), by participant.....	339
Figure 210 Modified Median Frequency Distribution (MMDF), by participant.....	340
Figure 211: Performance of MMNF (Phinyomark et al., 2009).....	341
Figure 212: Modified Mean Frequency Distribution (MMDF), by participant.....	342
Figure 213: EMG artefact detection by thresholding at 0.3mV. The portion of the signal with significant activity above the red line was caused by an artefact. After 23 seconds the sensor placement was corrected.....	342
Figure 214: Savitzky-Golay filter on skin temperature data.....	344

Figure 215: Effect of pre-processing with a median filter	344
Figure 216: Medium term skin temperature trend (three worst participants shown, to highlight problem), lower trace indicated the duration of the training period.....	346
Figure 217: Finger temperature curve during a series of depressive reactions. (Bela Mittelmann & Wolff, 1943).....	347
Figure 218: Typical skin temperature variation during a psychiatric interview (Bela Mittelmann & Wolff, 1943) ['RM TEMP' appears to be an error]	347
Figure 219: Normalisation method for skin temperature, shown on synthetic data. The red line showing normalised data had its baseline established during the period before the experiment started, while the participant was sitting in the chair and the electrodes connections were verified.	348
Figure 220: Peak detection of respiration data. Each red line is a detected peak.	349
Figure 221: Interrupted breath. The peak shown by the arrow appears to be made by some sort of pause in the regular breathing cycle.....	350
Figure 222: The signal obtained from a lower chest placement of the respiration sensor.	350
Figure 223: Respiration metrics. The coloured regions are used in a slope approximation function.....	351
Figure 224: Curve metric function. The metric for any of the sections shown is the area under the curve divided by the size of the box. A dark/light blue box is shown for inhalation and a dark/light green box is shown for exhalation.	351
Figure 225: Curve metric in synthetic form.....	352
Figure 226: Reference image of BVP Waveforms Pressure vs. Optical	352
Figure 227: Typical BVP waveform collected during our experiment.....	353
Figure 228: ECG and BVP signals for the same participant.	353
Figure 229: BVP waveform peaks. Major peaks in blue, minor peaks in red.	354
Figure 230: Slope based metrics and the BVP signal	355
Figure 231: Distribution of the IGSR (see IEMG) calculation for GSR signal.....	355
Figure 232: Distribution of the Mean Absolute Value Slope (MAVSLP) calculation for GSR Signal.....	356
Figure 233: Distribution variance calculation for GSR signal.....	356
Figure 234: Distribution IRMS calculation for GSR signal	356
Figure 235: Distribution Wilson Amplitude (WAMP) Calculation for GSR Signal.....	357
Figure 236: Feature sampling at 500ms.....	358

Figure 237: T-wave finish per-heartbeat sample	358
Figure 238: Random per-heartbeat sample	359
Figure 239: Nine label divisions of emotion space. The division is grid-based and uses a dead-zone of 1 (shown in large at the top), 2 (lower left) and 3 (lower right). The labels used on these figures correspond to labels used elsewhere, i.e. SAM3_5 is the 5 th label on a grid with a dead-zone of 3.....	364
Figure 240: A histogram showing the three bucket distribution archived by dead-zones of 1, 3 and 5.	365
Figure 241: The “data distribution donut” for SAM labels.	366
Figure 242: Clustering performance for SAM results; showing (A) The lowest value with performance similar to the minimum for the Davies–Bouldin index.	367
Figure 243: Distribution of clustering labels vs. grid scheme with a dead-zone of 3.	368
Figure 244: Two Voronoi plots of the results of our work to cluster the SAM responses. The plots are shown from two rotations and the three rating axes have been adjusted from the range [1 to 9] to the range [-4 to 4] so that 0 is neutral.....	369
Figure 245: Diurnal variations of mean skin conductance level (Pasca et al., 2005)	374
Figure 246: Mean amplitude of skin conductance (Pasca et al., 2005)	374
Figure 247: Mean values of emotional experience (Pasca et al., 2005)	375
Figure 248: Experiment timetable	375
Figure 249: Distribution of time of day when the experiment was conducted.....	376
Figure 250: GSR levels (normalised by person) over hourly time periods. Graph used 24hr time.	376
Figure 251: Valence ratings by slide. The slide number is the relevant IAPS ID. A Valence rating of 5 is Neutral. Above that is “bad or negative”, below that is “good or positive”. The slides are not in the same order they were presented to participants.	378
Figure 252: Arousal ratings by slide. The slide number is the relevant IAPS id. An Arousal rating of 5 is Neutral. Above that is “restful state”, below that is “exciting state”. The slides are not in the same order they were presented to participants.....	379
Figure 253: Dominance ratings by slide. The slide number is the relevant IAPS ID. A Dominance rating of 5 is Neutral. Above that is “in control”, below that is “awe/ not in control”. The slides are not in the same order they were presented to participants.	380

Figure 254: Comparison of our SAM ratings and those of reference studies. Responses that were chosen by more than one participant are labelled x2, x3 and so on. Male responses are in blue, female in red. A rectangle of matching colour is drawn to represent the area around the mean bounded by one standard deviation. The areas of one standard deviation about the mean from previous studies (P. Lang et al., 2001) are shown in grey.380

Figure 255: Comparison of our SAM ratings and those of reference studies. Responses that were chosen by more than one participant are labelled x2, x3 and so on. Male responses are in blue, female in red. A rectangle of matching colour is drawn to represent the area around the mean bounded by one standard deviation. The areas of one standard deviation about the mean from previous studies (P. Lang et al., 2001) are shown in grey.381

Figure 256: Scatter plot of SAM results for slide 2730. Responses that were chosen by more than one participant are labelled x2, x3 and so on. Male responses are in blue, female in red. A rectangle of matching colour is drawn to represent the area around the mean bounded by one standard deviation. The areas of one standard deviation about the mean from previous studies (P. Lang et al., 2001) are shown in grey.383

Figure 257: Result histograms for slide 2730. In the arousal graph lower numbers indicate excitement and higher numbers indicate calmness.383

Figure 258: Example result histogram (for Participant 2, on day 1).384

Figure 259: Table 17 displayed as a set of pie charts. The red zone indicates areas where our participants' results did not correlate with results obtained from previous studies. This could be due to significant cultural differences, errors in reporting feedback, other intangible aspects affecting the emotions of participants, or more extreme natural variance in emotional response.387

Figure 260: Example shotgun plot. The plot is broken up into discrete bins; in this case nine bins are present. The nine bins are one each for the nine areas the data has been grouped into. The nine bins are organised according to two sets of three labels which represent, in this case, the affective dimensions of Arousal (SAMA_0...SAMA_2) and Valence (SAMV_0...SAMV_2). Thus data in the three bins to the left of the graph is negative Valence (SAMV_0). Likewise data in the three bins along the top of the graph are related to positive Arousal (SAMV_2).389

Figure 261: Exhalation curve metric for three levels of Dominance. The mean is almost constant, however the distribution of values decreases as the results move from excited (SAMD_0) to calm (SAMD_2).....390

Figure 262: “Respiration peak height from last valley” metric plotted against Valence and Arousal.390

Figure 263: “Respiration peak distance from last valley” metric plotted against Valence and Arousal. The colours indicate the value of the metric.391

Figure 264: Scatter plot of typical EMG features and their ability to roughly categorise affective Valence states (shown in colour, blue = negative Valence, through green = neutral and red = positive). It is important to note that the graph shows heterogeneous data from multiple people. A general trend is evident in that neutral emotions yielded results lower and central to the shape of the plot.392

Figure 265: EMG data by Person arranged in a “waterfall”. The colour reflects Valence reported for the reading. Some participants (e.g. # 6) have EMG readings that are affected by the Valence of the stimulus; while others (e.g. #25) do not.....393

Figure 266: GSR Variance by person, coloured by Valence.394

Figure 267: Falloff of ECG signal metric. The grey area is the time in the stimulus and the white was recorded during rating tasks. The points shown are sampled randomly from all participants. The colour coding shows the results of the Arousal rating.394

Figure 268: Using an ECG and GSR metric to separate Dominance ratings.395

Figure 269: Using two ECG metrics to separate the clustered affective states.395

Figure 270: Using BVP and GSR Metrics to separate Arousal responses.396

Figure 271: FFS_NB training with meta data (dead-zone = 1). Local jumps in performance are seen for $p = 4, 6$ and 13 . After $p = 13$ the system stabilises, indicating additional features are unlikely to be of benefit. The results are coloured by p as a “rainbow” spectrum over the values of p examined.398

Figure 272: FFS_NB training with meta data (dead-zone = 2). Local jumps in performance are seen for $p = 7$ and 15 . As p approaches 20 the system continues to grow indicating more features need to be examined.398

Figure 273: FFS_NB training with meta data (dead-zone = 5). Local jumps in performance are seen for $p = 4, 6$ and 13 . As p approaches 20 the system peaks indicating sufficient features have been examined.399

Figure 274: FFS_NB training with meta data (group based labels). Local jumps in performance are seen for $p = 5$ and 15 . As p approaches 20 the system continues to grow indicating more features need to be examined.399

Figure 275: FFS_RF performance. Jumps in performance are evident for different sizes of feature sets (p), and as expected, the jumps are smaller as p increases. Notable significant improvements are found for $p = 2, 3$ and 5400

Figure 276: Forward feature selection (FFS) results obtained using a naive Bayes classifier on the grid based labels (samClassDZ3Div9). Each point represents the performance of a unique subset of features as tested in the FFS algorithm. The X axis represents the number of iterations the FFS algorithm has passed through.409

Figure 277: Forward feature selection (FFS) results obtained using a naive Bayes classifier on the cluster based Labels (samClassCluster8). Each point represents the performance of a unique subset of features as tested in the FFS algorithm. The X axis represents the number of iterations the FFS algorithm has passed through.409

Figure 278: Performance over all participants of a series of random forest classification tasks. Note: grid labels are in blue and cluster labels are red.412

Figure 279: Performance over all participants of a series of Support Vector Machine (SVM) classification tasks. Note: grid labels are in blue and cluster labels are red.413

Figure 280: Performance of naive Bayes classifiers.414

Figure 281: Summary confusion matrix for grid based labels trained via a naive Bayes classifier. As not all predictions are equally wrong, the matrix is displayed in a colour coded manner to indicate the nature of each error. The rightmost column provides summary statistics for each label in terms of True Positives, False Positives, False Negatives and True Negatives. The last row gives individual and total classification accuracies. The coloured areas are akin to a bar graph which shows that cells portion of the total predictions for the associated label. The colour represents the nature of the guess, blue for correct, two greens for level of similarity, pink for an unrelated state and red for a opposing state.415

Figure 282: Summary confusion matrix for clustered labels trained via a naive Bayes classifier.415

Figure 283: Clusters 5 (PPV = 54%) and 2 (PPV = 51%) highlighted for clarification of the naive Bayes classifier results.416

Figure 284: Random forest tuning for 12 participants. Shows results organised by the number of trees. Colour information is used to separate the participants. The number

of trees used was 2, 7, 12, 17, 22, 27, 32, 37, 42, 47 & 52. A “scatter” effect was applied over the points to allow easier visualisation, the nature of the scatter may change from graph to graph.417

Figure 285: Random forest tuning for 12 participants. Shows results organised by the number of trees. Colour information is used to show tree depth.418

Figure 286: Random forest tuning for 12 participants. Shows results organised by the depth of the trees. Colour information is used to separate the number of trees.....418

Figure 287: Random forest tuning for 12 participants. Shows results organised by the depth of the trees. Colour information is used to separate the participants, lines show the maximum performance for each participant at the given depth.....419

Figure 288: Histograms of performance of random forest classifiers for all participants. Histograms for cluster and grid labels are shown, each using 10% bins.420

Figure 289: Summary confusion matrix for grid based labels trained via a random forest classifier. As not all predictions are equally wrong the matrix is displayed in a colour coded manner to indicate the nature of each error. The rightmost column provides summary statistics for each label in terms of True Positives, False Positives, False Negatives and True Negatives. The last row gives individual and total classification accuracies. The coloured areas are akin to a bar graph which shows that cells portion of the total predictions for the associated label. The colour represents new nature of the guess, blue for correct, two greens for level of similarity, pink for an unrelated state and red for an opposing state.421

Figure 290: Summary confusion matrix for clustered labels trained via a random forest classifier.421

Figure 291: Clusters 5 (PPV = 70%), 6 (PPV = 70%) & 7 (PPV = 68%) highlighted for clarification of random forest results.422

Figure 292: ANN performance tuning. Results shown by number of layers and coloured by person.424

Figure 293: ANN performance tuning. Results shown by layer size (× number of inputs) and coloured by person.424

Figure 294: ANN Performance tuning. Results shown by number of training cycles and coloured by person.425

Figure 295: Fine tuning for grid and cluster labels shows no apparent visual trend. 427

Figure 296: Histograms of performance of ANN for all participants. Histograms for cluster and grid labels are shown, each using 10% bins.	429
Figure 297: Summary confusion matrix for grid based labels Trained via an ANN. As not all predictions are equally wrong, the matrix is displayed in a colour coded manner to indicate the nature of each error. The rightmost column provides summary statistics for each label in terms of True Positives, False Positives, False Negatives and True Negatives. The last row gives individual and total classification accuracies. The coloured areas are akin to a bar graph which shows that cell's portion of the total predictions for the associated label. The colour represents new nature of the guess, blue for correct, two greens for level of similarity, pink for an unrelated state and red for an opposing state.	430
Figure 298: Summary confusion matrix for clustered labels trained via an ANN. ...	430
Figure 299: Clusters 2 (PPV = 43%), 5 (PPV = 42%) & 7 (PPV = 42%) Highlighted for clarification of ANN results.	431
Figure 300: Plot of performance by distance measure, for grid labels. The Manhattan distance shows the best performance overall.	433
Figure 301: Plot of performance by distance measure, for grid labels. The Canberra distance shows the best performance overall.	433
Figure 302: Grid, for Manhattan distance measure, comparing values of k. The black line is the average performance across all participants.	434
Figure 303: Cluster, for Canberra distance measure, comparing values of k. The black line is the average performance across all participants.	434
Figure 304: Comparison of weighted voting performance for grid and cluster labels at k=4.	435
Figure 305: Performance of k-NN classifier.	436
Figure 306: Summary confusion matrix for clustered labels trained via a k-NN classifier.	437
Figure 307: Summary confusion matrix for grid labels Trained via a k-NN classifier.	437
Figure 308: Clusters 5 (PPV = 54%) and 2 (PPV = 51%) highlighted for clarification of the naive Bayes classifier results.	437
Figure 309: SVM, Linear kernel performance.	439
Figure 310: Polynomial kernel performance	440
Figure 311: RBF kernel performance.	441

Figure 312: Sigmoid kernel SVM tuning for grid	442
Figure 313: Sigmoid kernel SVM tuning for cluster	443
Figure 314: Performance of SVM classifier.	445
Figure 315: Summary confusion matrix for clustered labels trained via a SVM classifier.	446
Figure 316: Summary confusion matrix for grid labels trained via a SVM classifier.	446
Figure 317: Clusters 0 (PPV = 65%), 1 (PPV = 52%) and 3 (PPV = 52%) highlighted for clarification of the SVM classifier results.	446
Figure 318: Performance distributions by classification task. Results are in pairs (cluster and grid labels) for each classifier. The cluster results are in grey, while the grid results are in white.	448
Figure 319: Performance (prediction accuracy) by participant. Results coloured by classifier with average performances indicated by the lines. Squares show results for Grid labels and circles Cluster labels.	449
Figure 320: The hardware Self Assessment Manikin (SAM) device developed.	455
Figure 321: ECG Annotations against raw ECG signal.	457
Figure 322: Emotion labelling systems. Voronoi plots of the our clustering Labels (Left) are shown from two rotations and the rating axes have been adjusted from the range [1 to 9] to the range [-4 to 4] so that 0 is neutral. The grid labels (Right) show the Valence/Arousal emotional space divided into nine different labels.	459
Figure 323: Diagram of human anatomical terminology.	467
Figure 324: IAPS slide used in this study (continued next page)	470
Figure 325: IAPS slide used in this study (continued next page)	471
Figure 326: IAPS slide used in this study	472
Figure 327: SAM frequency histogram for participant 1, day 1	473
Figure 328: SAM frequency histogram for participant 2, day 1	473
Figure 329: SAM frequency histogram for participant 3, day 1	474
Figure 330: SAM frequency histogram for participant 4, day 1	474
Figure 331: SAM frequency histogram for participant 5, day 1	474
Figure 332: SAM frequency histogram for participant 6, day 1	475
Figure 333: SAM frequency histogram for participant 1, day 2	475
Figure 334: SAM frequency histogram for participant 2, day 2	475
Figure 335: SAM frequency histogram for participant 3, day 2	476

Figure 336: SAM frequency histogram for participant 4, day 2.....	476
Figure 337: SAM frequency histogram for participant 5, day 2.....	476
Figure 338: SAM frequency histogram for participant 6, day 2.....	477
Figure 339: SAM frequency histogram for participant 7, day 2.....	477
Figure 340: SAM frequency histogram for participant 8, day 2.....	477
Figure 341: SAM frequency histogram for (female) participant 1, day 3	478
Figure 342: SAM frequency histogram for participant 2, day 3.....	478
Figure 343: SAM frequency histogram for participant 3, day 3.....	478
Figure 344: SAM frequency histogram for participant 4, day 3.....	479
Figure 345: SAM frequency histogram for participant 1, day 4.....	479
Figure 346: SAM frequency histogram for participant 2, day 4.....	479
Figure 347: SAM frequency histogram for participant 3, day 4.....	480
Figure 348: SAM frequency histogram for participant 4, day 4.....	480
Figure 349: SAM frequency histogram for participant 5, day 4.....	480
Figure 350: SAM frequency histogram for (female) participant 1, day 5	481
Figure 351: SAM frequency histogram for participant 2, day 5.....	481
Figure 352: SAM frequency histogram for participant 3, day 5.....	481
Figure 353: SAM frequency histogram for participant 4, day 5.....	482
Figure 354: SAM frequency histogram for (female) participant 5, day 5	482
Figure 355: SAM frequency histogram for (female) participant 6, day 5	482
Figure 356: SAM frequency histogram for (female) participant 7, day 5	483
Figure 357: SAM frequency histogram for participant 8, day 5.....	483
Figure 358: SAM frequency histogram for participant 9, day 5.....	484
Figure 359: A plot of Arousal vs. Valence scores for slide 1050 (Snake), reference studies in grey.	485
Figure 360: A plot of Arousal vs. Valence scores for slide 1200 (Big Hairy Spider), reference studies in grey.	486
Figure 361: A plot of Arousal vs. Valence scores for slide 1300 (Angry Dog), reference studies in grey.	486
Figure 362: A plot of Arousal vs. Valence scores for slide 2000 (Smiling Male Face).	487
Figure 363: A plot of Arousal vs. Valence scores for slide 2070 (Human Baby).	487
Figure 364: A plot of Arousal vs. Valence scores for slide 2345 (Kids playing).....	488
Figure 365: A plot of Arousal vs. Valence scores for slide 2730 (Boy with bison)..	488

Figure 366: A plot of Arousal vs. Valence scores for slide 2900 (Boy Crying).....	489
Figure 367: A plot of Arousal vs. Valence scores for slide 3062 (Abortion).....	489
Figure 368: A plot of Arousal vs. Valence scores for slide 3069 (Girl [½ head blown away]).	490
Figure 369: A plot of Arousal vs. Valence scores for slide 3150 (Hand Cut up).....	490
Figure 370: A plot of Arousal vs. Valence scores for slide 3220 (Male Hospital Patient).....	491
Figure 371: A plot of Arousal vs. Valence scores for slide 4005 (Female Nude [discreet]).....	491
Figure 372: A plot of Arousal vs. Valence scores for slide 4150 (Female bikini). ...	492
Figure 373: A plot of Arousal vs. Valence scores for slide 4300 (Female [pornographic]).	492
Figure 374: A plot of Arousal vs. Valence scores for slide 4520 (Male Nude [discreet]).....	493
Figure 375: A plot of Arousal vs. Valence scores for slide 4535 (Male Lifting Weights).....	493
Figure 376: A plot of Arousal vs. Valence scores for slide 4572 (Handsome Fireman).	494
Figure 377: A plot of Arousal vs. Valence scores for slide 4641 (Couple at beach).	494
Figure 378: A plot of Arousal vs. Valence scores for slide 4666 (Couple in bed [not discreet]).	495
Figure 379: A plot of Arousal vs. Valence scores for slide 5621 (Skydiving formation).	495
Figure 380: A plot of Arousal vs. Valence scores for slide 4659 (Couple Sex [discreet]).....	496
Figure 381: A plot of Arousal vs. Valence scores for slide 5623 (Extreme windsurfing).....	496
Figure 382: A plot of Arousal vs. Valence scores for slide 5760 (Flower Garden). All female Arousal = 1.....	497
Figure 383: A plot of Arousal vs. Valence scores for slide 5780 (River). All female Arousal = 1.....	497
Figure 384: A plot of Arousal vs. Valence scores for slide 5910 (Fireworks [over city]).....	498
Figure 385: A plot of Arousal vs. Valence scores for slide 6550 (Violent Scene)....	498

Figure 386: A plot of Arousal vs. Valence scores for slide 7002 (Towel).	499
Figure 387: A plot of Arousal vs. Valence scores for slide 7009 (Mug).	499
Figure 388: A plot of Arousal vs. Valence scores for slide 7480 (Spaghetti).	500
Figure 389: A plot of Arousal vs. Valence scores for slide 7950 (Tissues).	500
Figure 390: A plot of Arousal vs. Valence scores for slide 8040 (High diver).	501
Figure 391: A plot of Arousal vs. Valence scores for slide 8490 (People in a roller coaster).	501
Figure 392: A plot of Arousal vs. Valence scores for slide 9000 (Graveyard).	502
Figure 393: A plot of Arousal vs. Valence scores for slide 9253 (Execution [young lady]).	502
Figure 394: A plot of Arousal vs. Valence scores for slide 9401 (Knives [subliminal words]).	503
Figure 395: A plot of Arousal vs. Valence scores for slide 9410 (Warzone [parent with child]).	503
Figure 396: A plot of Arousal vs. Valence scores for slide 9582 (Dental exam).	504
Figure 397: Advert for nurses	512
Figure 398: Notice to other students.	513
Figure 399: Advert for volunteers (for noticeboards)	514
Figure 400: Advert for volunteers (handout)	514
Figure 401: Notice displayed facing entrance to room.	515
Figure 402: Disclosure form (1 of 2)	516
Figure 403: Disclosure form (2 of 2)	517
Figure 404: Informed consent form	517
Figure 405: Median filter performance comparison for a 2.66GHz quad core Intel Q9450 (our solution is oobTree)	527
Figure 406: Structure used for efficient median filtering	528
Figure 407: Unbalanced tree	530
Figure 408: SAM tablet circuit diagram	531
Figure 409: Calculated nominal voltage (using preferred value resistors)	537
Figure 410: Voltage ranges for switches	539
Figure 411: Rounded integer threshold ranges for switches	540
Figure 412: Button duration - corrected errors	541

1.0 Introduction

"Problems worthy of attack prove their worth by fighting back."

- Paul Erdos (1913-1996)

This thesis examines emotion recognition via a process called Physiological Pattern Recognition (PPR), which is an attempt to examine physiological signals (signals related to the body) and find aspects of the signals that correlate with the emotional state of the subject.

The aim of this work is to improve the process in which a person's emotion can be recognised from their physiological signals; a process known as classification. The improvements we wish to make include prediction accuracy, as well as improving the number (and type) of emotional states detectable. Additionally we wish to explore/discover new features which can be extracted from physiological signals to assist in predicting emotion. Where possible we also wish to improve the speed with which these systems operate and the applicability to real time systems.

Physiological Pattern Recognition (PPR) is part of an effort to integrate emotions into computers that has resulted in a new field of research known as affective computing.

At first, the scope for emotional mechanisms to be present in computational devices may seem limited. However we are starting to see the computer being applied to more and more activities involving increasingly complicated human interaction. The success of such programs and devices is becoming increasingly based on how well the program interacts with the user, eg Tzvetanova et al., (2007), Han, Yun, Kwahk, & Hong, (2001), Grudin, (1992) and Lottridge, Chignell, & Jovicic, (2011).

As an example of a situation where emotional interaction is preferable to an emotionally naive system, consider a vehicle satellite navigation system that could determine if you are feeling lost and/or confused. Upon discovering the user is feeling lost, it can suggest an alternative driving route that may be suboptimal in terms of distance but less difficult to navigate for the driver.

An ongoing assessment of the driver's confidence and mood can do more than help a navigation device choose whether or not to suggest a "backstreet shortcut". It can also prevent the device from becoming a backseat driver by accurately choosing the amount of information the user actually needs. For instance the device would remain silent during the driver's trip to work, until sensing the driver was frustrated (more

than usual) and the car is moving slowly. The unit could then suggest an alternate route with less congestion. A cumulative report of driver emotions delivered from such devices could also be used to inform city officials of roads that often cause users to experience anger, fear or frustration.

In the human thought process, emotions play an essential role in decision making (Schwarz, 2000), (Bechara, Damasio, & Damasio, 2000), (Bechara, 2004), (Toda, 1980). It is widely observed that outcomes of decisions will be influenced by what mood the person making the decision is in. In this respect, computers are sometimes considered at an advantage for not having emotions. The lack of emotions makes the decisions and actions of the computer more predictable. As shown by Lewis, Hair and Schoenberg (1989) this predictability of software makes certain interactions less complicated and as such “predictability” is a primary tenant of user interface design (Wickens, Gordon, & Liu, 2004, rule 13).

However, not all computer interactions are of a non-social nature. A good example of this is the help and information kiosks used in shopping centres. Some shopping centres will employ humans to provide information to shoppers in need of assistance, while others will provide a computer. Normally the computer will be running software which can provide help with most common queries, provide store locations and maybe communicate in several languages. These computers may be more technically capable of performing the information kiosk task, but are completely unable to properly assist a crying five year old who has lost his mother. A computing device capable of interpreting the child’s emotion, would know to use reassuring language with the child. Such a system would also be able to judge when a PA announcement was warranted, assisting children/parents; but not falling for teenagers pranks.

As computing devices become more prevalent in our daily lives, both in terms of our work and recreational activities, a more sophisticated interaction closer to human to human interaction is often sought after; an idea recently explored with practical applications by Swindells et al., (2007), who demonstrated successful improvements in tactile interface devices.

To date, humans and computers have both been evolving techniques to learn to work together but there remains a void in the interaction between man and machine. This “void” is the result of the machine having no emotional capacity. An effort to close this void has resulted in a new field of research known as affective computing (Picard, 1997a).

Emotions play a vital role in the decision making process of humans. Simplistically, a person’s actions and decisions are largely biased by how that person is feeling. When humans interact with each other, the success of the interaction is largely related to how well the humans handle each other’s emotions. However, when computers interact with a human, little to no effort is applied to reacting to the user’s mood. Table 1 lists examples of tasks where an emotionally aware software system would be better able to support humans, or be preferable to current software solutions.

Table 1: Emotionality aware solutions to affective problems in computing.

Task	Affective Problem
Computer Game:	Determine when the user is getting bored and adjust the game play to suit.
Driver Assistance:	Determine if the driver is distracted before alerting the driver of an unsafe situation that has been detected. It is often critical that the driver assistance equipment avoids being an annoying “backseat driver” that distracts the driver from the task at hand.
Operating System: Action Requests	Suppress maintenance messages such as “Would you like to perform a desktop clean-up now?” when the user is working hard and concentrating on something.
Operating System: File Manager	If the user is distracted or very tired when deleting a file, have the file linger in the recycle bin for a longer period of time than usual.
Mobile Phone:	If the person wearing the phone is engaged in a conversation or deeply involved in performing a task, redirect calls from numbers not listed as important to a voice mail service.
Product Help Systems:	Some programs will present helpful hints in the form of

	<p>dialogue boxes. When a user interacts with a part of a program they have not used before, such systems could detect if the user has become worried, upset or confused before offering assistance. Such assistance is often resented by users who do not require the help nor want any interruptions.</p>
<p>Operating System: User Interface</p>	<p>Often, users will dress up their desktop environment by creating custom colour schemes and desktop wall papers. Appropriate decoration of the user interface often results in a less stressful experience using the machine. Such decorative schemes could be cycled to suit the mood of the user.</p>
<p>Music Player:</p>	<p>Customise the selection of music being played to suit the user's mood.</p>
<p>Pace maker:</p>	<p>Examine anxiety levels to determine whether a cardiac episode is the result of an anxiety attack (or an actual heart problem) and report to the doctor (and patient) important information on the nature of the episodes experienced. It may even be possible for a device to calm someone down via an "internal" speaker that announces "Nothing is wrong, this is only anxiety".</p>

Emotion recognition is a vital first step in creating affective systems and can be measured using five separate techniques:

- Examining facial expressions through computer vision (Ekman & Rosenberg, 2005);
- Speech analysis (Kim, Hyun, & Kwak, 2005);
- Body language (De Silva et al., 2006)
- Brain imaging / Electroencephalography (EEG) (Choppin, 2000);
- Content examination (i.e. looking at the words used in a document);
- Physiological Pattern Recognition (PPR).

PPR aims to recognise emotion through examining a person's physiological state (how their body is functioning). This is an important step towards real world emotion recognition systems because:

- They are hard to manipulate (can't mask your feelings) (VanDenBroek, Lisy, Westerink, Schut, & Tuinenbreijer, 2009);
- Have a good signal to noise ratio (VanDenBroek et al., 2009);
- Can be very unobtrusive (Axelrod, 2009), (van den Broek, Janssen, Healey, & van der Zwaag, 2010) & (Haag, Goronzy, Schaich, & Williams, 2004);
- Are very cheap (van den Broek, Zwaag, Westerink, & Healey, 2011), (Khan, 2008);
- Are viable in embedded systems (R. Picard & Healey, 2005);
- They may have practical advantages in many situations, such as being integrated into clothing (C. L. Lisetti & Nasoz, 2004).

The advantages of PPR are in contrast to the issues faced by the other previously mentioned techniques of emotion recognition. For application in general human computer interaction, it is important to consider that computers cannot always see our faces, we do not often speak to computers and EEG's (or other brain scanning devices) are often not available in the standard home desktop setup (though there are some consumer level devices emerging (Snyder, Weste, Le, & Do., 2010)).

We do, however tend to touch things while using them and through touch a large amount of physiological data can be collected using cheap and non-invasive sensors. This is where PPR has great potential in the upcoming real world applications of affective computing.

Touch based signal acquisition methods available to affective systems include:

- Keyboards;
 - Pressure of key strike.
- Computer mice/joysticks and vehicle steering wheels;
 - Signals acquired from the hands, including skin temperature, skin conductivity, pulse and blood oxygen levels.
- Seats (car, cinema, office);
 - Signals relating to posture and amount of fidgeting.
- Wearable computing devices;
 - Many assorted signals depending on how the object is worn.

Currently it cannot be said for certain whether PPR will ever work well in practice and there is a lack of rigorous scientific results to conclusively show that PPR is possible beyond simple tasks (e.g. detecting stress). The major problems facing PPR include:

- No consistent results (VanDenBroek et al., 2009);
- No general standards (VanDenBroek et al., 2009);
- Low performance of classification tasks (VanDenBroek et al., 2009);
- Intra-personal variance in signal behaviour and predictable correlations, both short and long term (Picard, Vyzas & Healey 2001);
- Inter-personal variance in signal behaviour and predictable correlations resulting from various sources including physiology and personality (Picard, Vyzas & Healey 2002).

The goal of this work is to help establish techniques to make PPR a more viable process and establish a more rigorous understanding of how to conduct experiments in the field of PPR. Secondly, we aim to contribute to a set of general standards and processes for physiological signal processing and feature extraction techniques.

The major questions this work aims to explore include:

1. Can the PPR experimental procedure be improved?
2. Can the analysis of PPR data be improved?
 - Can improvements in signal pre-processing techniques (cleaning, normalising, and correction) produce better classification results?
 - Can we discover new signal features that will improve classification results?
 - Will an application of various classification algorithms assist in improving results?
3. Can we create a PPR system that in some way also predicts the Dominance factor of the emotion being examined?

The PPR experimental procedure is difficult to implement because many factors affect human emotion and physiological signals. We will aim to improve upon the state of the art, and produce a well-documented repeatable procedure for participant handling, stimulus selection, equipment setup and obtaining feedback. As there is no other well documented procedure for this this contribution would be a useful milestone allowing researchers the benefit of a reference implementation.

Additionally we wish to improve the PPR experimental procedure by examining in detail a set of common physiological sensors and their use in this type of experiment. Specific focus will be given to reviewing the field of facial electromyography as there is no single reference that reviews all the muscles of facial movement and the related electrical activity from a PPR perspective.

Analysis of PPR data is a daunting exercise. There are many methods to pre-process the raw data collected, then there are many features that can be from that data. Then there is a selection of classification algorithms available to work with these features.

We recognise that to identify emotion from physiological signals we are often working with the change in the physiological state as a source of data for classification purposes. The metrics we produce must be stable, not altering due to noise or other signal properties not related to a physiological change. This entails investigating our processing signals with a great deal of rigor and time. Additionally we also extracted a broad range of features for classification purposes. Finally we compared classification rates using multiple classifiers, so as to identify any possible advantages.

Lastly we argue the practical importance of a factor of emotional experience, known as Dominance. Then we show a successful classification system that uses this aspect is both practical and desirable.

This work is set out with several chapters concerning the background and relevant literature. Chapter 2 discusses some fundamental theories in emotion and how computational classification systems work.

We provide a review of the current literature in Chapter 3. The review encompasses emotion theory, physiological systems and the state of the art in detecting human emotion from physiological signals.

Chapter 4 is used to review the human facial muscles and their role in displaying emotion. This review is done from the perspective of electromyography (EMG) recordings. Chapter 5 continues the investigation into facial muscles by presenting a set of experiments we conducted using EMG sensors and posed facial expressions.

In Chapter 6 we present our experimental methodology which is then fully detailed later in Chapter 7 (methods and materials). Chapter 8 discusses one of our innovations in the experimental procedure and presents a hardware device we built specifically for this work.

We present an explanation of the signal processing and feature detection techniques we used in Chapter 9. Much of the focus is on our work with electrocardiograms and facial electromyography.

We analyse and validate our collected data in Chapter 10. Chapter 11 covers our results in emotion classification using a variety of classifiers. The conclusion can be found in Chapter 12. As this thesis draws from four disciplines; Human Physiology, Signal Processing, Computational Intelligence and Psychology, a useful set of terms from these fields is included in a glossary in Chapter 13.

Finally a set of appendixes cover:

1. The stimulus slides we used;
2. Participant results;
3. Results gathered by slide shown;
4. Our novel Electrocardiogram (ECG) period transforms;
5. Implementation of algorithms;
6. Notices and communications used to find and inform participants;
7. Risk management report on safety issues in the experiment;
8. Email communications used in booking participants;
9. Our median filtering algorithm implementation and performance improvements;
10. Circuit diagrams, circuit board schematics and all other information needed to reproduce our Self Assessment Manikin (SAM) hardware device.

2.0 Background

“Any emotion, if it is sincere, is involuntary.”

-Mark Twain (1835 - 1910)

This thesis draws from various areas of research, primarily utilising the disciplines of computer science, signal processing, psychology, physiology, human biology and neurology. Regular use of jargon from all these fields will abound in this work and a comprehensive glossary (see page 463) is provided for the reader's convenience.

This chapter establishes a background in emotion related theories which are used throughout the text. We discuss here:

- What emotions are;
- The cultural and natural components of emotion;
- How we organise, categorise and quantify emotions for research purposes;
- The computational means by which we perform classification.

The final two parts of this chapter introduces the classification techniques that will be used to predict the emotion present for the physiological data collected.

2.1 What are Emotions?

The question of what is an emotion is a topical point of discussion in modern sciences of the mind. It can best be answered as "we are not sure yet". This means that studies of emotional processes lack a clear basis and must link observations and theories together rather tenuously.

We lack a basic unified theory of emotion much in the same way physicists lack a unified theory of general relativity. This means the core of our science is not yet understood, but does not prohibit interesting work from being conducted.

A classical summary of the many different answers to the question "What is an emotion?" is presented in Kleinginna & Kleinginna (1981). This work presents definitions proposed by just over a hundred authors and attempts to summarise the field with an all-inclusive definition:

"Emotion is a complex set of interactions among subjective and objective factors, mediated by neural/hormonal systems, which can (a) give rise to affective experiences such as feelings of arousal, pleasure/ displeasure; (b) generate cognitive processes such as emotionally relevant perceptual effects, appraisals, labelling processes; (c) activate widespread physiological adjustments to the arousing conditions; and (d) lead to behaviour that is often, but not always expressive, goal-directed, and adaptive". (p. 355)

This definition is not intended to be precise, but instead covers all possibilities, including what may well be wrong. Most researchers currently accept one of three often opposing definitions of emotion. These theories are:

- The James-Lange theory;
- The Cannon-Bard theory;
- The two factor theory.

These theories are briefly outlined in the following sections.

2.1.1. **The James-Lange Theory**

The James-Lange theory of emotion (James, 1884) proposes that emotions are the cognitive interpretation of physiological changes that occur in response to an action.

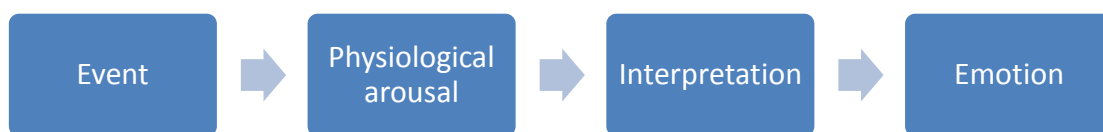

Example: I see a crocodile (event); my muscles tense and my heart races (physiological arousal); I am in danger (interpretation); I feel afraid (emotion).

The theory suggests also that a person's action comes first and the emotion is a result of that action. For example deliberately smiling might make you feel happier. This theory would allow for Physiological Pattern Recognition (PPR) to be solidly grounded as a theoretical process for identifying emotions.

2.1.2. The Cannon-Bard Theory

Developed by physiologists Walter Cannon and Philip Bard (Cannon, 1927), this theory was a direct challenge to the previously established James-Lange theory. The premise is that emotions are felt directly as the result of an event and physiological changes happen at the same time we feel an emotion.

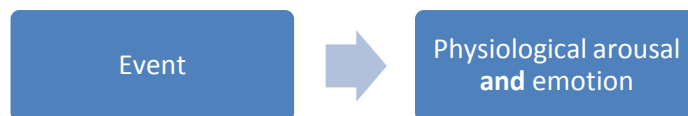

Example: I see a crocodile (event); I feel afraid (emotion) and my muscles tense and my heart races (physiological arousal).

This theory could weaken the theoretical basis for identifying emotions if the correlation between a person's emotion and the experienced physiological state was weak.

2.1.3. The Two Factor Theory

The Two Factor theory (Schachter & Singer, 1962) asserts that emotions have two components (factors): physiological arousal and cognition (reasoning).

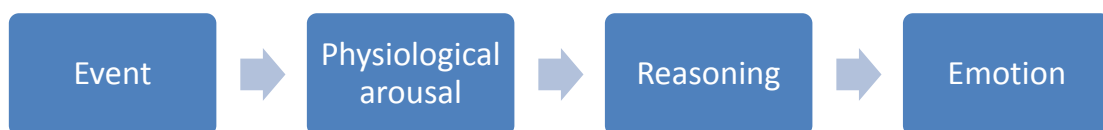

Similar to the James-Lange theory, this theory views reasoning as being part of what determines an emotional state. In layman's terms, we seek to explain our physiological changes by (subconsciously) deducing the emotion that would best explain a physiological change.

A classic experiment in this theory was conducted by Dutton and Aron (1974). In this experiment, an attractive woman asks young men for interviews both on terra firma and on a swaying rope bridge 60 meters above a river. Part way through the interview,

the interviewer would express a romantic interest and give the participant her phone number. It was found that more than 60% of rope bridge participants called the number, versus 30% of the terra firma participants. It was concluded that the rope bridge participants had interpreted their arousal, from fear of being on the bridge, as attraction to the woman.

If this theory is correct then research into PPR would consider physiological cues as highly significant. However it would indicate that contextual cues (that hint at the users' reasoning process) would be necessary to properly interpret the physiological signals.

2.2 Culturally Specific Emotions

Theories on origin of emotions in humans generally fall into one of two categories, social constructionism or naturalism. Social constructionism proposes that adult human emotions result from social concepts while naturalism proposes emotions to be a universal phenomenon, independent of social norms and conscious interpretation.

Social constructionism has been widely advocated by many researchers (Averill, 1985; Averill & Nunley, 1988; Gergen, 1985a, 1985b; Hannigan, 1995; Harré, 1986; T. D. Kemper, 1981, 1987; Nightingale & Cromby, 1999; Ratner, 1989). The basis of the theory separates emotions into two classes. The first is those which have natural analogues in animals and (human) infants, but become mediated processes in the adult human brain. Joy, sadness and fear are prime examples. The second group of emotions is thought to exist only in humans as a special case because of our particular social and cognitive capacities. For example, entire cultures, such as the Eskimo, lack anger, according to Solomon (1984).

The effects and nature of various culturally specific emotions are discussed throughout this thesis, most prominently in section 3.2.

2.3 Emotions from a Research Perspective

Working with emotions presents many challenges, however it is still possible to work with them and obtain new knowledge. Rosalind Picard (Picard, 1997, pg 21) outlined the basis for using the term “emotion” in research; essentially saying that even though there is no accepted and exact definition of what an emotion is, we still have a strong intuitive concept of what an emotion is. The term “emotion” may be poorly defined, but it is still an understandable and usable word. We can base a lot of work on the intuitive and simple aspects of emotion that are highly unlikely to be redefined if a precise definition of what an emotion is, is ever found.

An example of the way in which research can remain robust, despite loose definitions, is Palmore’s 25 year long study into indicators of life expectancy Palmore (1982) found satisfaction to be one of a set of primary indicators in predicting someone’s longevity, stating:

“The strongest independent predictors for men were health self-rating, work satisfaction, and performance intelligence; for women they were health satisfaction, past enjoyment of intercourse, and physical function rating. These predictors could constitute a combined difference in longevity of 16 years for men and 23 years for women.”

Though “satisfaction” is an emotional state which cannot be defined exactly in terms of its neurological/biological/psychological components, we can still see that the knowledge of satisfaction being linked to lifespan remains valid regardless of changes in the definition or understanding of “satisfaction”.

Before embarking on research in emotion classification, we must organise emotions in a manner that allows us to deal with them in a logical or mathematical sense. Furthermore, to build solid knowledge on top of a variable definition of emotion we

must find a way to organise emotions that is supported by major emotional topology theories¹.

The following sections present an overview of how emotions can be organised into topologies for scientific quantification. Major theories are discussed and finally we show how we intend to represent emotional states.

2.3.1. Emotion Organisation Theories

As mentioned in Section 2.1, there is no current agreement on what an emotion is. This is only the first stumbling block on the road to working with emotions scientifically. The next problem is that there is no agreement on which mental states are emotions and which are not. There is also no standard topology for organising these states, which may or may not be emotions. Figure 1 shows a proposed hierarchical view of current emotion topology theories.

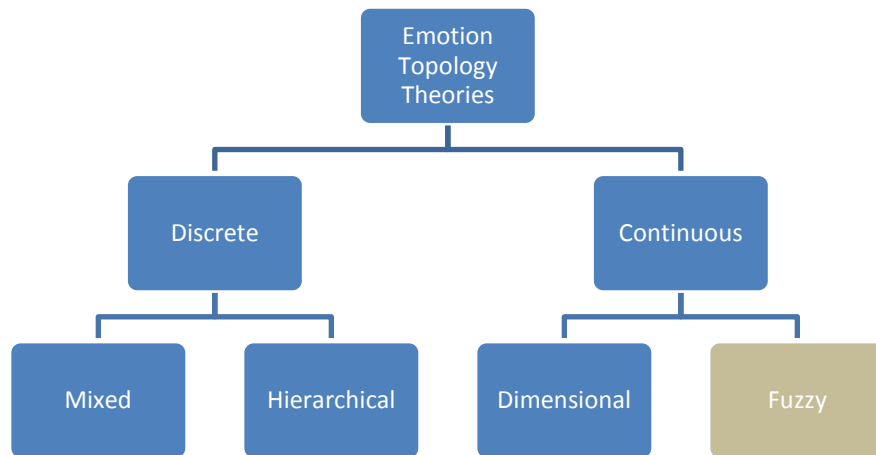

Figure 1 : Emotion theory heirarchy

From this figure it can be seen that the first major distinction in classifying emotions is whether emotions form as discrete sets (Ekman, 1992) or a continuous space (Russell, 1980). By discrete sets, we mean individually separate and distinct emotions.

¹ Such organisational topologies are occasionally referred to in literature as “emotion classification theories”. The term is confusing and is not related to using mathematical classifiers to predict emotions.

While by continuous space, we refer to emotion as being a singular unbroken concept which is measured by sever scalar attributes.

There are many views on which "affective states" should be considered an emotion; generally this is of greater concern to discrete emotion theories. In finding a topology to organise emotions many theorists divide emotions into groups; primary, secondary and even tertiary. Primary emotions (Ekman, 1999) are generally seen as basic affective states common to all people and possibly even animals.

Some theories then go on to state that emotions may be mixed together to form new secondary emotions while other theories propose a hierarchical layout of emotional states.

A secondary emotion is generally seen as being "complex", that is, it is a refined version of a basic emotion, or a culturally specific emotion. Secondary emotions are defined differently in two different sets of sub theories, mixed emotion theories and hierarchical emotion theories (see Figure 1).

Table 2 shows a set of emotions considered to be primary emotions by major researchers (most commonly recognised states in red). There are a lot of emotions (too many to list) that have been proposed as secondary emotions and some debate as to their importance. A good summary of existing works was conducted by Ortony and Turner (1990). Expanding on this summary, Table 2 compiles a list of possible primary emotions, tallied against supporting studies. The top six most identified emotions are shown in red.

Table 2: Primary emotions by study

Emotion	Iza 71	Ekm 72	Jam 84	Pan 82	Tom 84	Gra 85	Plu 80	Ekm 92	Par 01	Pri 04
amusement		✓								
anger	✓	✓			✓		✓	✓	✓	
anticipation/expectency				✓			✓			
anxiety						✓				✓
attachment										✓
aversive self-consciousness										✓
contempt		✓								
contentment	✓	✓			✓					
disgust	✓	✓			✓		✓	✓		
distress	✓	✓			✓					
embarrassment		✓								
excitement		✓								
fear	✓	✓	✓	✓	✓		✓	✓	✓	
frustration										✓
grief			✓							
guilt	✓	✓								
happiness or joy	✓	✓			✓	✓	✓	✓	✓	
interest	✓				✓					
love			✓						✓	
panic				✓						✓
physical disgust										✓
pride in achievement		✓								
rage			✓	✓		✓				
relief		✓								
sadness		✓					✓	✓	✓	
satisfaction		✓								✓
sensory pleasure		✓								
separation distress										✓
shame	✓	✓			✓					
stimulation										✓
surprise	✓	✓			✓		✓	✓	✓	
terror						✓				
trust							✓			

The studies compared in Table 2 are as follows:

- Ekm 72 (Paul Ekman, 1972)
- Ekm 92 (P. Ekman, 1992)
- Plu 80 (Plutchik, 1980)
- Pri 04 (Prinz, 2004)
- Par 01 (Parrott, 2001)
- Gra 85 (Gray, 1985)
- Iza 71 (Izard, 1971)
- Jam 84 (James, 1884)
- Pan 82 (Panksepp, 1982)
- Tom 84 (Tomkins, 1984)

2.3.2. Hierarchical Emotion Classification Theories

A prominent hierarchical emotional topology was proposed by Parrott (2001). This topology, shown in Table 3, uses six primary emotions, of which all other emotions are specialised forms.

Table 3: Parrot's heirachy of emotions

Primary emotion	Secondary emotion	Tertiary emotions
Love	Affection	Adoration, affection, love, fondness, liking, attraction, caring, tenderness, compassion, sentimentality
	Lust	Arousal, desire, lust, passion, infatuation
	Longing	Longing
Joy	Cheerfulness	Amusement, bliss, cheerfulness, gaiety, glee, jolliness, joviality, joy, delight, enjoyment, gladness, happiness, jubilation, elation, satisfaction, ecstasy, euphoria
	Zest	Enthusiasm, zeal, zest, excitement, thrill, exhilaration
	Contentment	Contentment, pleasure
	Pride	Pride, triumph
	Optimism	Eagerness, hope, optimism
	Enthrallment	Enthrallment, rapture
	Relief	Relief
Surprise	Surprise	Amazement, surprise, astonishment
Anger	Irritation	Aggravation, irritation, agitation, annoyance, grouchiness, grumpiness
	Exasperation	Exasperation, frustration
	Rage	Anger, rage, outrage, fury, wrath, hostility, ferocity, bitterness, hate, loathing, scorn, spite, vengefulness, dislike, resentment
	Disgust	Disgust, revulsion, contempt
	Envy	Envy, jealousy
	Torment	Torment
Sadness	Suffering	Agony, suffering, hurt, anguish
	Sadness	Depression, despair, hopelessness, gloom, glumness, sadness, unhappiness, grief, sorrow, woe, misery, melancholy
	Disappointment	Dismay, disappointment, displeasure
	Shame	Guilt, shame, regret, remorse
	Neglect	Alienation, isolation, neglect, loneliness, rejection, homesickness, defeat, dejection, insecurity, embarrassment, humiliation, insult
	Sympathy	Pity, sympathy
Fear	Horror	Alarm, shock, fear, fright, horror, terror, panic, hysteria, mortification
	Nervousness	Anxiety, nervousness, tenseness, uneasiness, apprehension, worry, distress, dread

2.3.3. Mixed Emotion Classification Theories

A major influence in discrete emotion theories was the late Professor Robert Plutchik who proposed a wheel of emotions (Plutchik, 1980) which organised eight primary emotions and eight secondary emotions, see Figure 2.

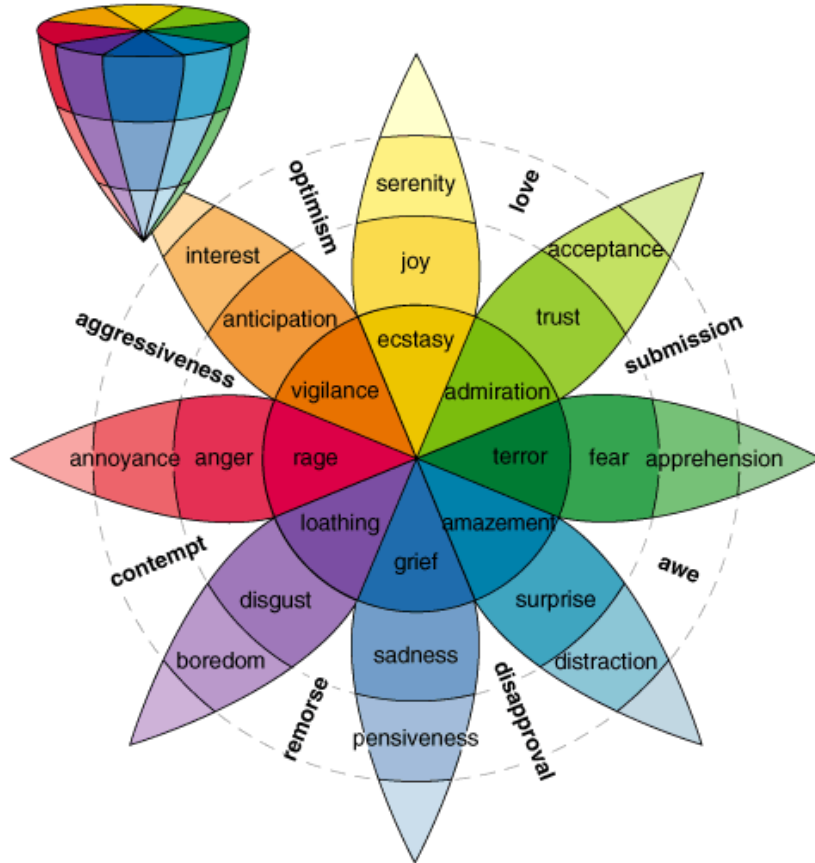

Figure 2: Plutchik's wheel of emotions

Plutchik's wheel organised eight emotions into four opposing pairs (e.g. ecstasy vs. grief). The eight emotions could be experienced at different intensities and mixed together to form secondary emotions. This is referred to as 'mixed' emotion because many emotions are consisted a combined or derivative states of basic, primary (prototype) emotions. It does not refer to the state where someone may feel "two ways" about something.

2.3.4. Dimensional Emotion Classification Theories

The idea of expressing emotions in an N-Dimensional space where the axes were various affective traits was first proposed by Osgood, Suci, and Tanenbaum (1957) in their seminal work on the semantic differential. This work used subjective bipolar (opposing) rating scales to measure meanings or connotations associated with items or concepts. An example is shown in Figure 3.

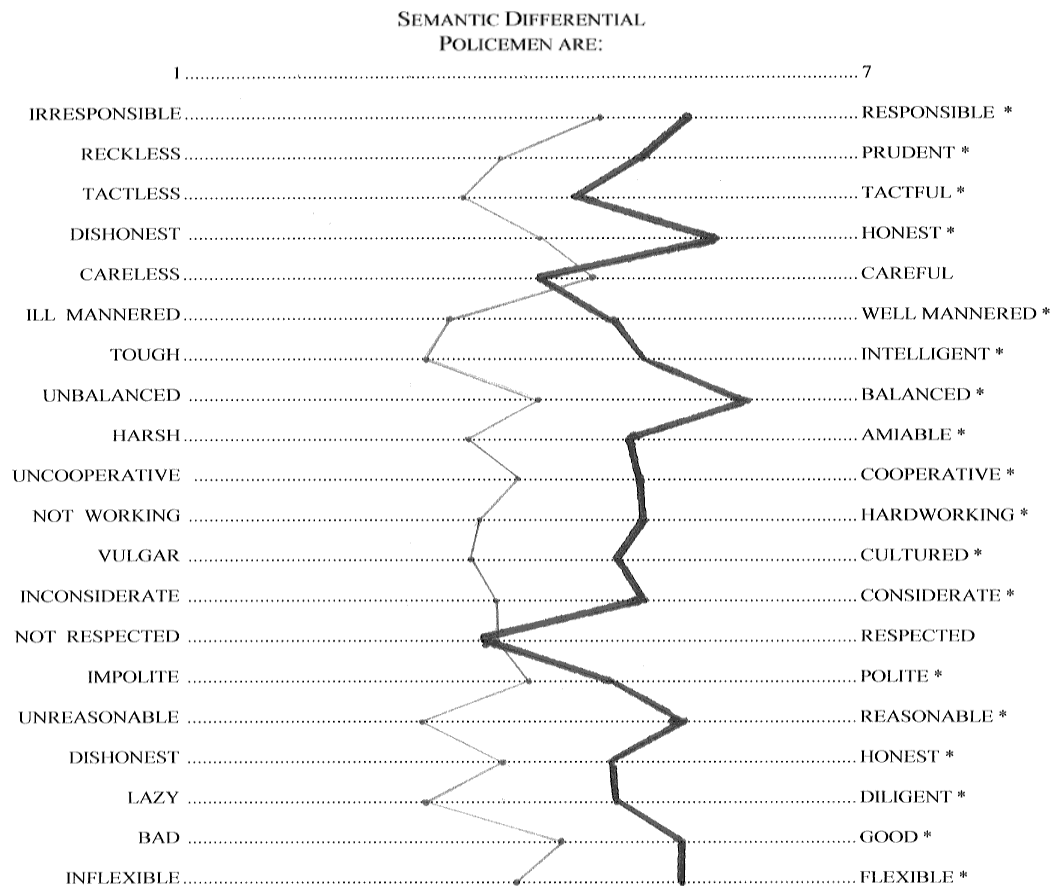

Figure 3: Semantic Differential, showing two peoples ratings for “policemen” (Pagon, 1996).

Osgood, Suci, & Tanenbaum (1957) performed factor analyses on their data and concluded that the variance in the emotional assessments were accounted for by three major dimensions (rating scales):

- Arousal (exciting & active vs. relaxing & calming);
- Valence (a good feeling vs. a bad feeling);
- Dominance (feeling in control vs., feeling in awe).

Applying this discovery to emotion topology theories allowed researchers to view emotions as multiple continuous levels of different emotional elements. A major work

in this field was the Circumplex Model of Emotions by James Russell (Russell, 1980). Russell used the Valence and Arousal axes to plot emotional states. An example of his work is shown in Figure 4. Often The Dominance axis is omitted as it is the least strongly correlated, and is not required for the subject areas involved e.g. (Surakka & Anttonen, 2005), (Feldman, 1995), (Lewis et al., 2007) & (Kulic & Croft, 2007). In section 3.6 Dominance is covered more extensively as we argue the case for increased use of the Dominance in affective HCI research.

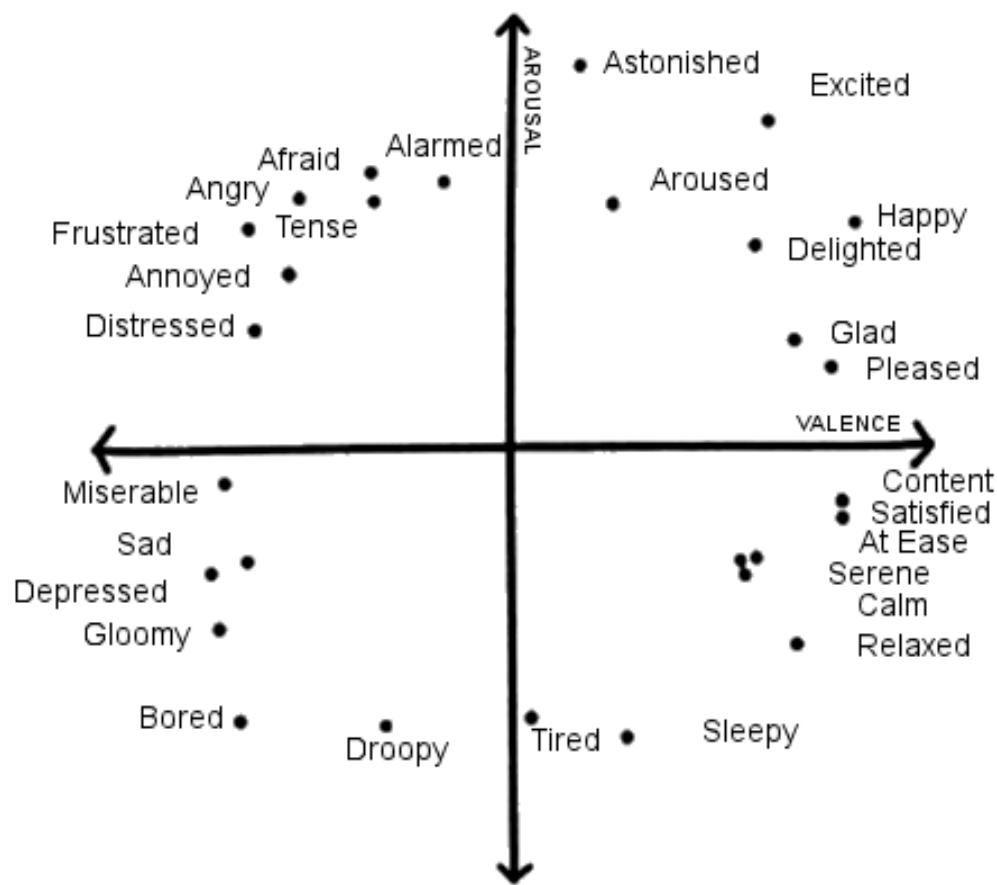

Figure 4: The circumplex model of emotion. Russell (Russell, 1980) plotted different emotions on a two dimensional space created by two axes, arousal and Valence. These axes of Arousal and Valence can have both positive , neutral and negative values.

From this point forward we will use the capitalised terms Valence, Arousal and Dominance when referring to the respective emotion space dimensions.

2.3.5. Fuzzy Emotion Classification Theories

The field of fuzzy emotion classification sets is aimed at bridging the discrete and continuous topologies. By using fuzzy set membership, discrete classifications can be imposed on an arbitrary emotion space. Liu, Zhu, Sun and Yang (2006) present a modern take on this approach using Fuzzy C-mean clustering (A clustering algorithm which allows one piece of data to belong to multiple clusters) to divide the basic Valence-Arousal model into a set of subspaces that they then show is a feasible classification method for one of their experiments.

2.3.6. Conclusion

We have reviewed several techniques to represent emotion. The dimensional model stands out as quite suitable for this work as it is non-discretising. This is asserted to be (Posner, Russell, & Peterson, 2005) an important consideration in relation to how emotion forms in an interconnected neurophysiological system (two factor theory). Thus, for an experiment in emotions that is based on physiological data, the dimensional model is very apt. This view is consistent with many other researchers in PPR who have also used dimensional models e.g. Katsis et al., (2008); Nakasone, Prendinger & Ishizuka, 2005; Picard (1997).

2.4 Overview of Classification Techniques Relevant to PPR

Classification algorithms are models which predict the class which corresponds to a series of observations. They are typically created using a training set for which the class belonging to each observation is known and the resulting model is then evaluated in terms of its accuracy in predicting the correct class.

Typically, a functioning classification algorithm, once trained, is employed to use data in “feature space” (considered an n-dimensional space with one dimension for each type of feature recorded) to create an estimate of the corresponding class (also called label). This process is shown in Figure 5. Typically the accuracy with which the classifier performs is considered the primary metric by which we evaluate the

classifier's usefulness or performance. The accuracy of a classifier can be given as a percentage, but often further metrics concerning the classifier's performance are useful. This subject is covered in the next section.

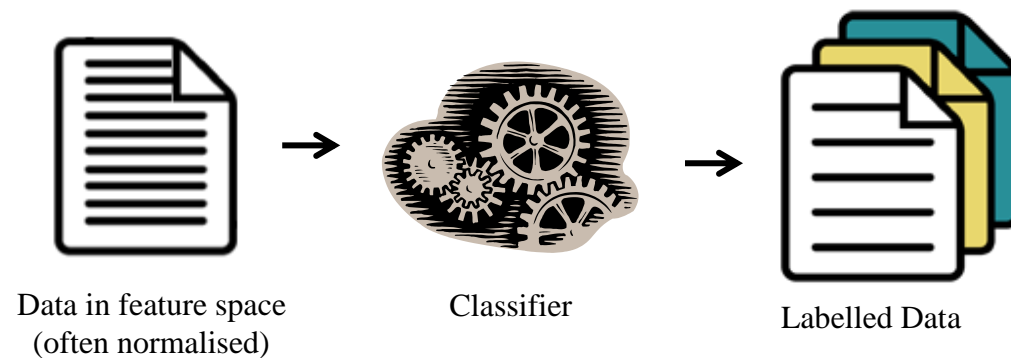

Figure 5: Operation of a working classifier

2.4.1. Assessing the Performance of a Classifier

Classifier performance is typically tabulated in the form of a Confusion Matrix (Tan, Steinbach, & Kumar, 2005, pg 144). This matrix, as shown in Table 4, tabulates all predictions against the actual (correct) class. The diagonal of the matrix holds correct predictions, and other cells indicate how often one class is mistaken for another.

Table 4: Example Confusion Matrix. The diagonal is shown in grey.

		Prediction		
		Dog	Cat	Fish
Actual	Dog	5	2	0
	Cat	1	6	1
	Fish	0	0	4

There exist numerous methods to visualise the performance of a classifier. In essence visualisation of classifier performance is done to allow for investigation of:

- How often the classifier can predict the correct class;
- Rate of false positives (other classes classified as the class being examined);
- Rate of false negatives (the class being examined is misclassified);
- Primary mis-classifications (which classes get mixed up);
- Determine classifier performance in relation to a threshold or execution speed trade-off;

- Compare classification techniques.

Methods commonly employed to do this visualisation principally use, or are derived from, the Confusion Matrix. Such methods include the ROC curve, lift (Pareto) chart and calibration plot are often also employed. See Vuk & Curk (2006) for more information on these charts.

Ideally a classifier will behave as shown in Figure 6-a; that is it will, based on the training data, assign a sensible portion of the feature space to each type of class. There may be some data points which are not separable, as per Figure 6-d, which will ultimately reduce the performance of the classifier. Points such as these are often inherent in the data being classified, but if there are too many it is a sign that more features may be required in order to make a good separation.

A poorly trained classifier may have a separation that is too general, as per Figure 6-b. It is also possible that a classifier may “over learn”, or learn its data set in a way that doesn’t generalise. In this case the performance on the training data will appear extremely good, but later performance on new data will be extremely poor. An example of this is shown in Figure 6-c where the boundary, although valid for the given data set, is obviously not as able to accommodate new data as Figure 6-a.

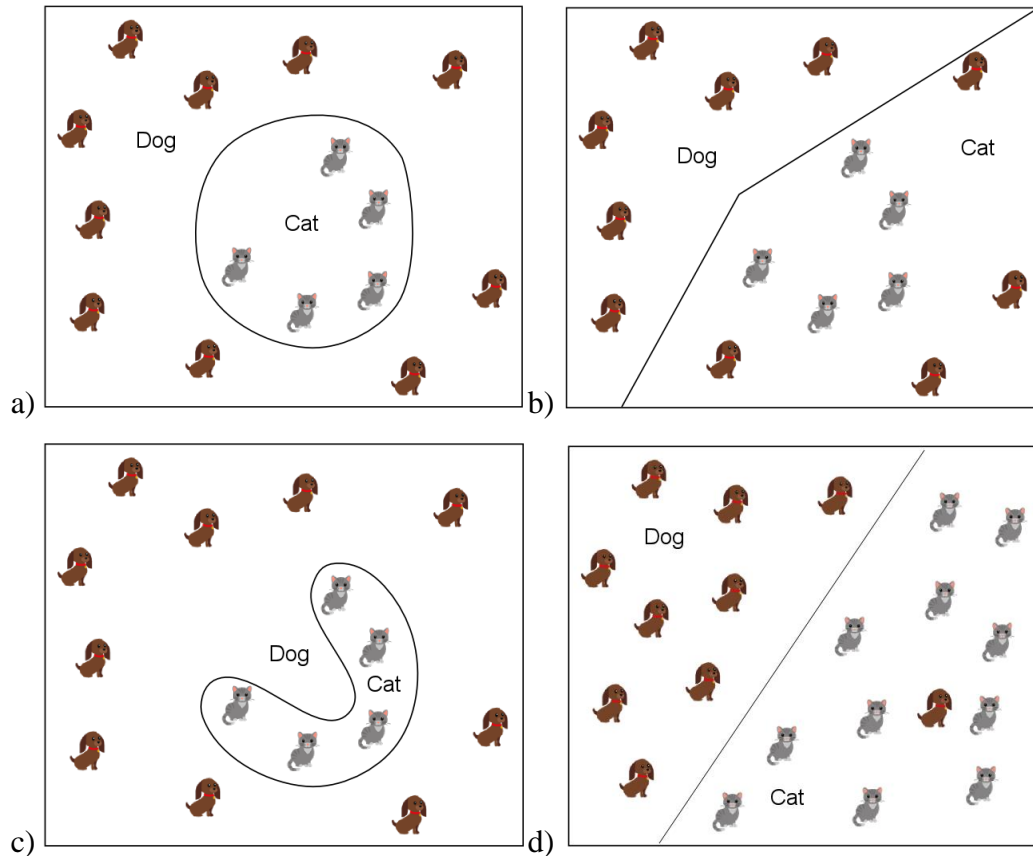

Figure 6: Examples of Classifier Boundaries in Feature Space. A) Is an ideal. B) Shows a poor fit. C) Shows an over-fit. D) Show a data item that cannot be fitted.

Sensitivity and Specificity

Sensitivity and specificity, see (Bland, 2000), are useful metrics which show the performance of a classifier (or other test). Sensitivity measures the samples correctly identified as being part of a class. Specificity measures the proportion of samples correctly identified as not being part of the class (negatives). These measures, shown in Equation 1, are related to the False Positive Rate (α) and False Negative Rate (β) discussed later in this section.

$$Sensitivity = \frac{TP}{(TP + FN)} \quad Specificity = \frac{TN}{(FP + TN)}$$

Equation 1: Formulae for Sensitivity and Specificity; Where TP = True Positives, FN = False Negatives, FP = False Positives & TN = True Negatives.

A perfect predictor would have 100% sensitivity and 100% specificity; however theoretically any classifier will have a minimum error rate; known as the Bayes Error

Rate (Bayes, 1763)¹; for a more modern work see Hand (1986). A graphical example of classifier sensitivity and specificity is shown in Figure 7.

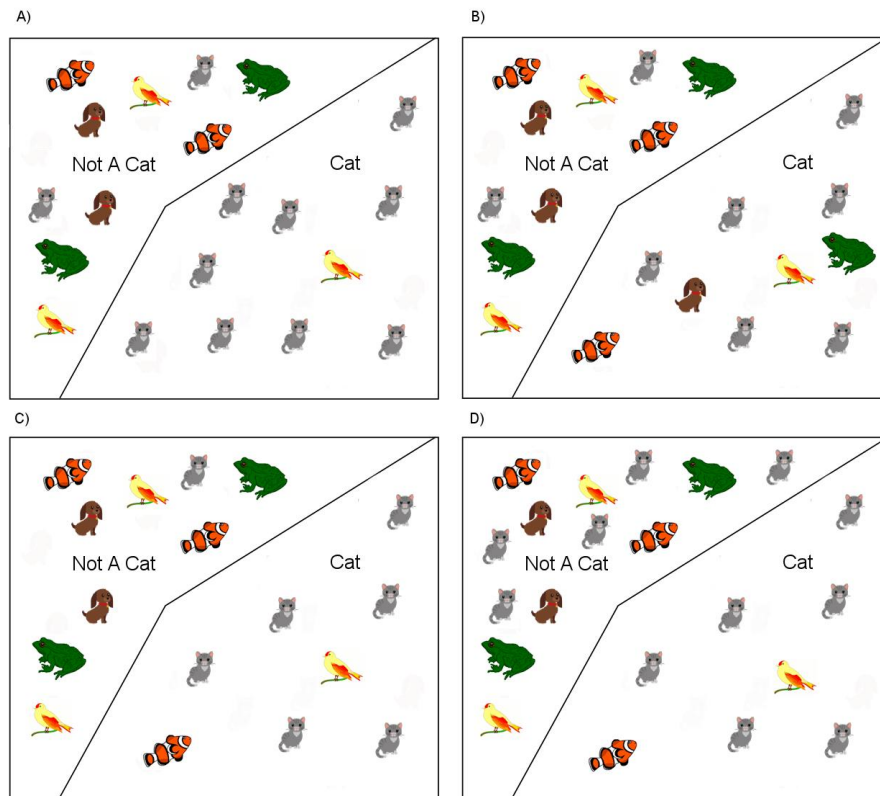

Figure 7: Sensitivity and Specificity Shown Graphically. A) High Specificity; B) Low specificity; C) High Sensitivity; D) Low Sensitivity.

Positive Predictive Value and Negative Predictive Value

The Positive Predictive Value (PPV) is the proportion of positive classifications which are correct. Likewise the Negative Predictive Value (NPV) is the portion of the negative classifications which are correct. These metrics are given in Equation 2.

$$PPV = \frac{TP}{(TP + FP)} \quad NPV = \frac{TN}{(TN + FN)}$$

Equation 2: Formulae for Positive Predictive Value (PPV) and Negative Predictive Value (NPV); Where TP = True Positives, FN = False Negatives, FP = False Positives & TN = True Negatives.

¹ Citation is of recovered historical notes, as Thomas Bayes did not publish this work before his death.

These tests provide the probability that a Positive or Negative result is correct. Its value is dependent on the prevalence of the class being tested, which may be unknown for some data sets.

False Positive Rate and False Negative Rate

The False Positive Rate (α) and False Negative Rate (β) represent the Type I and Type II errors respectively; as shown in Equation 3.

$$\alpha = 1 - \text{Specificity} = \frac{FP}{(FP + TN)}$$

$$\beta = 1 - \text{Sensitivity} = \frac{FN}{(TP + FN)}$$

Equation 3: Formulae for False Positive Rate (α) and False Negative Rate (β); Where TP = True Positives, FN = False Negatives, FP = False Positives & TN = True Negatives.

The False Positive Rate and False Negative Rate are often used in statistical hypothesis testing.

2.4.2. Overview of the k-NN Classifier

The kNN classifier is a simple and powerful classification algorithm used in a wide variety of fields, and is discussed in detail by Zhang & Zhou (2007). This classifier stores the feature space and label of every element of the training data it is presented with. When it is asked to classify an unknown value, it finds the k training examples closest to the new value (known as the nearest neighbours) and reports the most frequently occurring class in the set (majority vote).

An example of k-NN applied to a hypothetical two dimensional feature set is shown in Figure 8. The data set records an animal's height and noise level. Further each record is labelled dog or cat (the class). A “?” shows the point of enquiry for a new set of features of unknown class. When taking the majority vote of the k=4 nearest

neighbours the classification is dog by a vote of 3 to 1. When $k=6$ is used the result is still dog, but by a vote of 4 to 2.

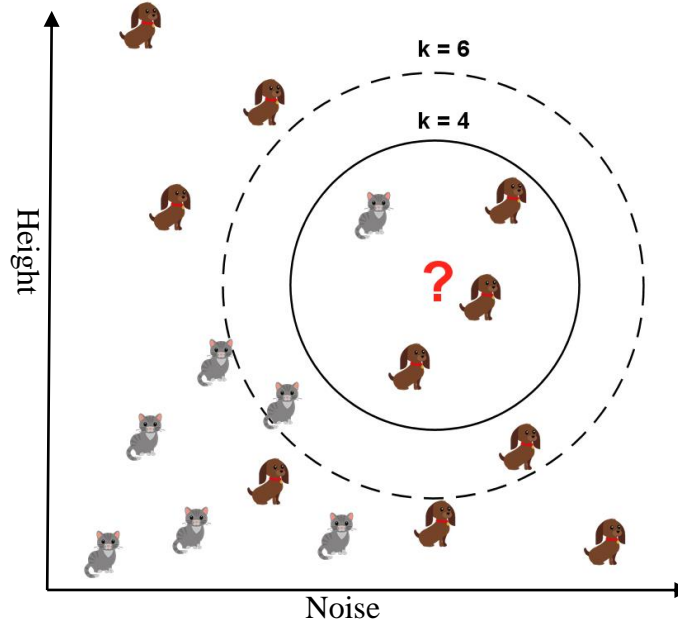

Figure 8: Example of k-NN on a 2 dimensional dataset.

The k-NN classifiers can utilise various metrics to measure the closeness of the various feature space points. In this work we trialled several numerical distance metrics, expressed as $d(q, p)$ to express the distance between the points q and p :

- Euclidean Distance;

$$\circ d(q, p) = \sqrt{\sum_{i=1}^n (q_i - p_i)^2}$$

- Canberra Distance (Lance & Williams, 1966);

$$\circ d(q, p) = \sum_{i=1}^n \left(\frac{|q_i - p_i|}{|q_i| + |p_i|} \right)$$

- Chebychev Distance (Abello & Pardalos, 2002);

$$\circ d(q, p) = \max_i (q_i - p_i)$$

- Correlation Similarity (Rodgers & Nicewander, 1988);

$$\circ d(q, p) = \frac{\sum_{i=1}^n (q_i - \bar{q})(p_i - \bar{p})}{\sqrt{\sum_{i=1}^n (q_i - \bar{q})^2} \sqrt{\sum_{i=1}^n (p_i - \bar{p})^2}}$$

- Cosine Similarity (Tan et al., 2005);

$$\circ d(q, p) = \cos(\theta_{qp}) = \frac{q \cdot p}{\|q\| \|p\|} = \frac{\sum_{i=1}^n (q_i p_i)}{\sqrt{\sum_{i=1}^n (q_i)^2} \sqrt{\sum_{i=1}^n (p_i)^2}}$$

- Dice Similarity (Dice, 1945);
 - $d(q, p) = \frac{2|q \cap p|}{|q|^2 + |p|^2}$
- Dynamic Time Warping Distance (Myers & Rabiner, 1981);
 - $d(0, 0) = 0$
 - $d(q, 0) = d(0, p) = \infty$
 - $d(q, p) = \sqrt{\sum_{i=1}^n (q_i - p_i)^2} + \min \begin{cases} d(q, p[2:n]), \\ d(q[2:n], p) \\ d(q[2:n], p[2:n]) \end{cases}$
- Jaccard Similarity (Jaccard, 1901);
 - $d(q, p) = \frac{q \cap p}{q \cup p}$
- Manhattan Distance (Krause, 1987);
 - $d(q, p) = \sum_{i=1}^n |q_i - p_i|$
- Max Product Similarity (Delibasic, Jovanovic, Vukicevic1, Suknovic, & Obradovic, 2011);
 - $d(q, p) = \max_i (q_i p_i)$
- Overlap Similarity (Lawlor, 1980).
 - $d(q, p) = \frac{|q \cap p|}{\min\{|q|, |p|\}}$

2.4.3. Overview of Artificial Neural Network Classifiers

Artificial Neural Networks (ANN) are a computational model inspired by biological central nervous systems (neurons, dendrites, axons and synapses). In an ANN, artificial nodes called Processing Elements (PEs) are connected together to form a network similar to biological neural networks.

Neuroscience is still full of unanswered questions and startling new discoveries continue to be made, such as the role of magnetic fields in the brain acting like synapses (Anastassiou, Perin, Markram, & Koch, 2011). As such there are many ways in which to approximate our understanding of biological neural networks. The term “artificial neural network” is a generalised term for many constructs which attempt to mimic the behaviour of their biological counterparts.

The ANN was first used on real data sets by Bernard Widrow and Marcian Hoff (Widrow & Hoff, 1960) at Stanford to eliminate telephone line echo. Despite some early success, an influential criticism on the limitations of ANN's was presented in a book by Minsky and Papert (1969). This and other factors (allegedly) inhibited the growth of ANN research for nearly 20 years.

In the 1980's, interest in Neural Networks rose quickly after a seminal paper by John Hopfield (Hopfield, 1982) which presented a thorough mathematical analysis of which tasks could and could not be solved by neural networks. Since this resurgence in interest, ANN's remain an active and productive research topic.

A modern ANN is typically arranged into layers of Processing Elements (PE's). The first layer is designated the input layer, and the last the output layer. Any layers in-between are referred to as hidden layers. Each PE functions by using multiple input values to create a single output value, using what is called an activation function. The network is arranged with the outputs of one layer connected, in a weighted fashion, to the inputs of the next layer. An example of this layout is shown in Figure 9. Note the darkness of the line is used to indicate the connection weighting.

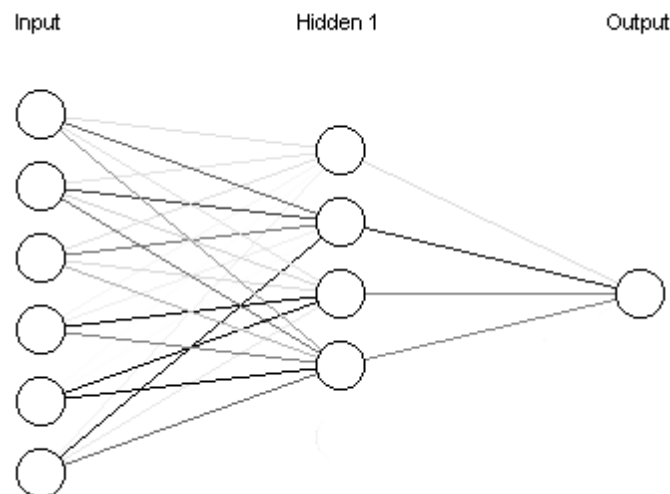

Figure 9: ANN setup with one hidden layer

ANN's have been shown to solve a wide variety of problems in many fields. Generally the tasks performed by neural networks can be divided into the following categories:

- Function approximation;
- Time series prediction;
- Classification;
- Pattern recognition;
- Data filtering;
- Feature detection;
- Robotics and industrial control;
- Simulations and game AI.

It is the possibility of using ANN's to achieve data classification which concerns the tasks of this work. A broad survey of ANN based classifiers and related problems / technologies is presented by Zhang (2000) who describes ANN based classification as "the most researched topic of neural networks". Further reviews by Lippman (1989) have also explored the breadth and depth of this wide topic. For the purposes of this overview however we present the typical neural network arrangement for a classification task in Figure 10.

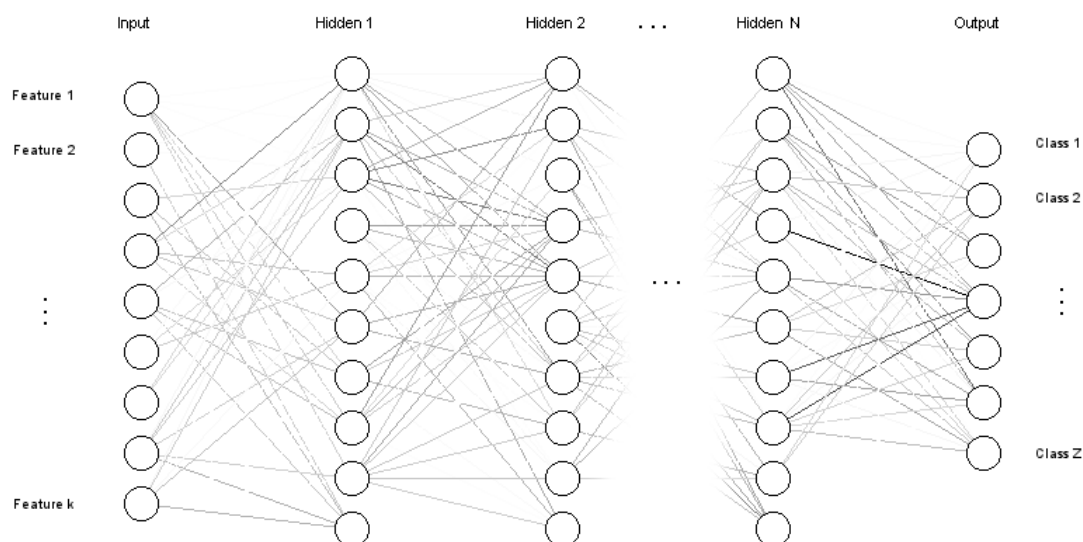

Figure 10: Typical ANN setup for classification

In this setup there is an input layer that has one PE per item in the feature space and the output layer has one PE for each possible classification result. When the network executes the output PE with the highest value decides the result of the classifier.

2.4.4. Overview of the Support Vector Machine Classifier

A Support Vector Machine (SVM) is a supervised learning method which separates two classes by constructing a hyper-plane which separates the training data. The original feature space may be mapped into a much higher dimensional space, so as to make the separation easier.

Hsu, Chang and Lin (2010) present a popular guide for rapidly obtaining acceptable results from SVM classification. A more in depth resource for a (more) complete understanding of the field is the book (dedicated to this subject) by Hamel (2009).

The points nearest to the separating hyper-plane are called support vectors. Only the support vectors determine the position of the hyper-plane, all other points have no effect. An example of this is shown in Figure 11.

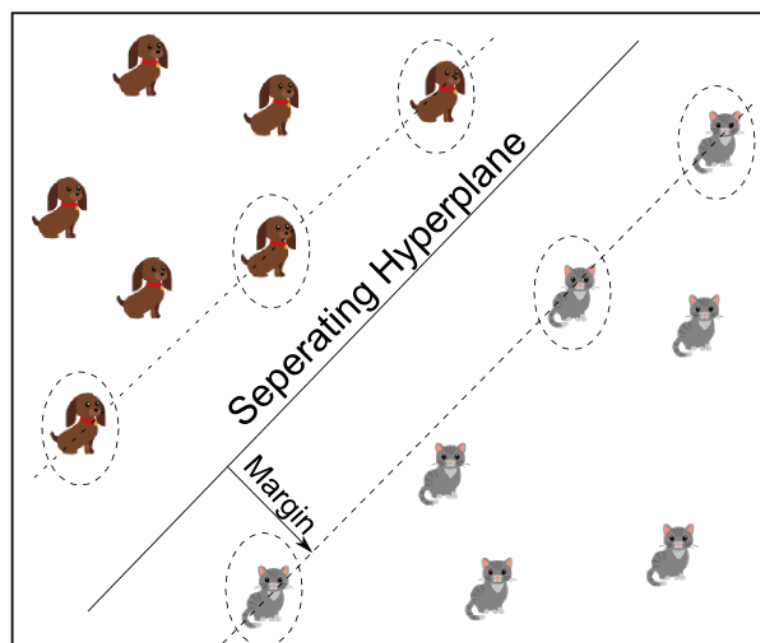

Figure 11: Support vector machine setup

A desirable property of the SVM classifier is to achieve good separation between the hyper-plane and the nearest (training) data point of any class. Henceforth this

separation will be referred to as the *margin*. To increase the accuracy in which the points are separated by the hyper-plane, as well as improve the margin, it is often necessary to transform the training points into a higher dimensional space, see Figure 12.

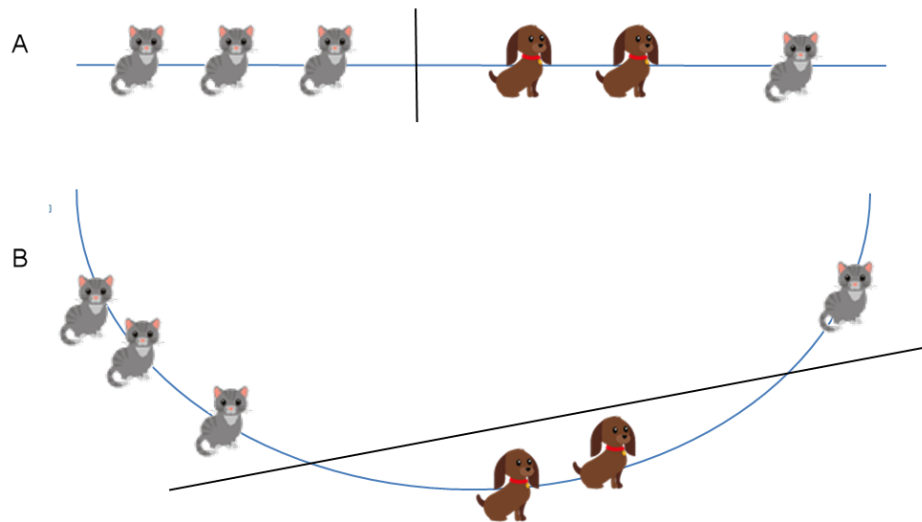

Figure 12: Allowing for better separation of training points by projecting the data (part A, in 1 dimension) into a higher dimensional space (part B, in 2 dimensions). The hyper plane is shown in black.

The SVM classifier relies on the calculation of dot products between training points. Rather than calculating the dot products in the higher dimensional space (both difficult and computationally expensive) the *kernel trick* is used to help train the SVM. The kernel trick uses a *kernel function* which is a dot product in the expanded feature space to allow the computation of dot products in terms of the original data points. The “best” kernel function to use changes between problem domains.

In this work we will use the recommendations of (Hsu, Chang, & Lin, 2010) and examine four different kernels:

- Linear $K(x_i, x_j) = x_i^T \cdot x_j + c$
- Polynomial $K(x_i, x_j) = (\gamma \cdot x_i^T x_j + c)^d; \gamma > 0$
- Radial Basis Function (RBF) $K(x_i, x_j) = EXP(-\gamma ||x_i - x_j||^2); \gamma > 0$
- Sigmoid $K(x_i, x_j) = \tanh(\gamma \cdot x_i^T x_j + c)$

Where the values γ (gamma), c and d are the kernel parameters which we will have to optimise to achieve the best classification performance.

2.4.5. Overview of the Naive Bayes Classifier

The Naive Bayes Classifier is a probabilistic classifier based on Bayesian statistics (Bayes & Barnard, 1958). It is referred to as Naive because each feature is considered independent when the training is performed, as discussed by Rish (2001). Ignoring covariance between features may introduce some limitations; however this classifier performs remarkably well on real world complex problems, and often requires smaller training sets.

Formally the classifier selects the most likely classification V_{nb} given the attribute values $a_1, a_2 \dots a_n$. This is expressed as:

$$V_{nb} = \underset{v_j \in V}{\operatorname{argmax}} P(v_j) \prod_i P(a_i | v_j)$$

Where $P(a_i | v_j)$ is generally determined by:

$$P(a_i | v_j) = \frac{n_c + mp}{n + m}$$

where:

n = the number of training examples for which $v = v_j$

n_c = number of examples for which $v = v_j$ and $a = a_i$

p = a priori estimate for $P(a_i | v_j)$

m = the equivalent sample size

Many researchers feel the Naive Bayes Classifier seems oversimplified and should not perform as well as it does, however Zhang (2004) was able to discover a theoretical rationale for the apparently unreasonable performance of Naive Bayes Classifiers.

Naive Bayes Classifiers are often used in Emotion recognition problems, as demonstrated by (N Sebe, Lew, Cohen, Garg, & Huang, 2002), (Nakasone, Prendinger, & Ishizuka, 2005), (Nicu Sebe, Cohen, Gevers, & Huang, 2006), (Ball & Breese, 1999), (Jiang & Cai, 2004) and (Qi & Picard, 2002). However recent studies have suggested Random Forests (discussed later in section 2.4.7) may outperform the

Naive Bayes Classifier, one example being described Caruana and Niculescu-Mizil (2006).

2.4.6. Overview of the Decision Tree Classifier

A decision tree works in a similar method to the children's game "20 questions". The goal of the classifier is to create a set of queries (against items in the feature space) and based on the answer to the initial query, a more pertinent query is then run against the feature space to derive further information. A simplified animal type classifier decision tree is shown in Figure 13.

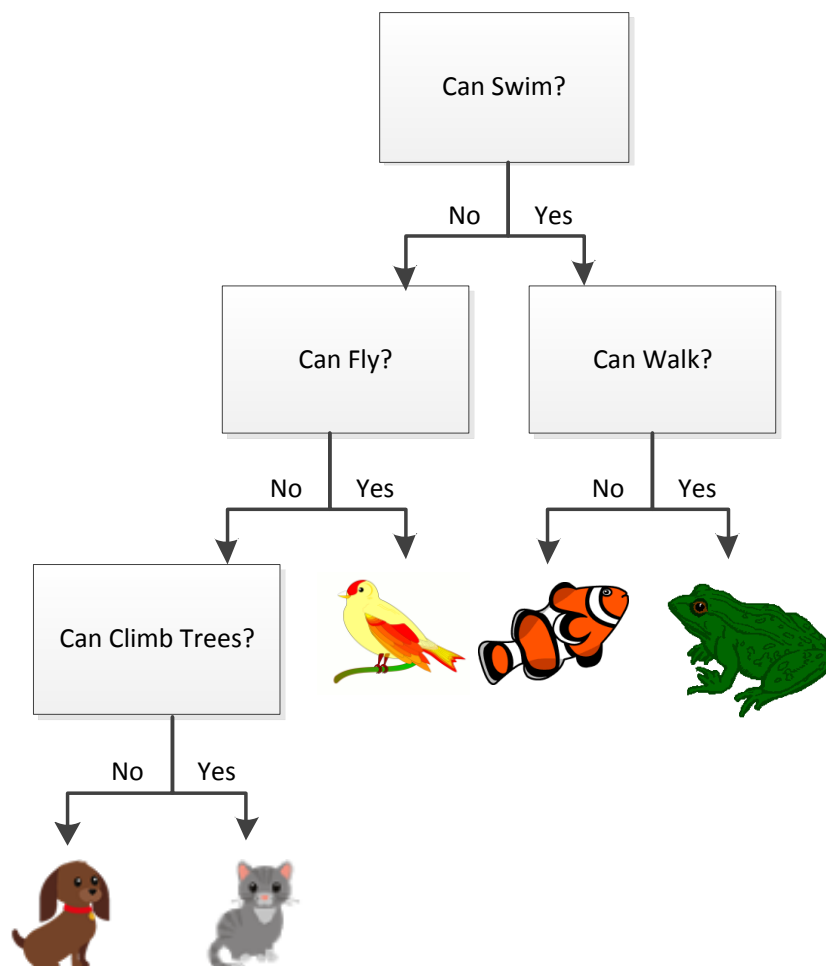

Figure 13: A Trivial Decision Tree Example

Decision trees offer the following benefits:

- Simple to understand and interpret. (The tree is human readable);
- Requires minimal data preparation. (no normalisation, dummy variables or removal of missing values);
- Able to handle both numerical and nominal (label) data;
- It is possible to validate a model using statistical tests;
- Performs classification quickly, making it suitable for large data sets;
- Trains quickly, making it suitable for complex (and exhaustive) feature selection tasks.

However there are some disadvantages:

- Decision-tree training can create an over-complex tree that performs poorly and needs to be "pruned" or simplified regularly;
- Some problems and relationships are not suited to a nested decision process, and will result in huge trees or poor performance, Exclusive-Or being an example of such a relationship.

There are portions of information theory essential to the training operation of many decision tree implementations such as the popular algorithms by Quinlan. Quinlan's algorithms are known as the ID3 algorithm (Quinlan, 1986) and the C4.5 algorithm (Quinlan, 1993). These algorithms begin constructing a decision tree with the best available feature, and then iteratively refine it using the next best feature. In this form of "top down" training features are often ranked for inclusion by combining one or more of the following information theory purity metrics:

- Entropy (Shannon, 1951);
- Information gain, also called the Kullback–Leibler divergence (Kullback & Leibler, 1951);
- Gini impurity (Gini, 1912);
- Relief-F (Wang & Makedon, 2004).

The idea of a purity (or impurity metric) is to examine the similarity of the subsets created by the decision tree. For example entropy, in this context, is a measure of the uncertainty associated with a random variable. It is used as a heuristic to achieve

smaller decision trees (simpler theories) over larger ones. The formula for computing the entropy for a given attribute is given in Equation 4. As $E(S)$ approaches 0 the set approaches perfect classification. By computing Entropy heuristics for every node in the tree it is possible to determine which nodes most need to be split into more nodes to allow for better classification.

$$E(S) = - \sum_{j=1}^n f_s(j) \log_2 f_s(j)$$

Where :

- $E(S)$ is the information entropy of the set S ;
- n is the number values for the examined attribute in S
- $f_s(j)$ is the frequency of the value j in the set S

Equation 4: Entropy Heuristic for Decision Trees

2.4.7. Overview of the Random Forest Classifier

The random forest classifier (Breiman, 2001) is a collection of many decision trees which gives a classification decision based on a majority vote of all its contained trees. It has the following advantages:

- It is one of the most accurate learning algorithms available (Caruana, Karampatziakis, & Yessenalina, 2008);
- It can handle large amounts of input variables.

However, random forests can overfit for some datasets (Segal & Segal, 2004).

The random forest uses a set of decision trees which are all trained on a subset of the available features. Each tree is trained as follows:

1. Given N , samples in the training set, select N cases at random (allowing for the same case to be sampled multiple times). This will form the training set for growing a tree;
2. Given M input variables, select m ($m < M$) variables at random to be used in training the tree;
3. Each tree is grown to the largest extent possible. (i.e. no pruning).

It has been shown (Breiman, 2001) that the random forest error rate depends on two things:

- The correlation between any two trees in the forest. Decreasing the correlation decreases the random forest error rate;
- The accuracy of each individual tree in the forest. Increasing the accuracy of the individual trees improves the performance of the random forest classifier.

The value m is linked to both the correlation and the accuracy. Increasing it increases both, whereas decreasing m reduces both.

2.5 Overview of Techniques Related to Classifiers

In this section we review some methods and tasks related to the classification algorithms which are used throughout this work. We will examine:

- Forward Feature Selection (a technique to select from a set of features the most relevant subset).
- N-Fold cross validation (a technique to stop a classifier learning its data set specifically, and thus not generalising well to real data).

2.5.1. Overview of the Forward Feature Selection Algorithm

The forward feature selection procedure (Guyon & Elisseeff, 2003) starts by evaluating the performance of a classifier on each feature attribute. Taking the best result, the algorithm then evaluates the performance of each possible feature subset comprised of the previously found best features and a single feature from the remaining features. The process continues in this fashion until a set amount of features have been identified.

A problem with this procedure is that there is no guarantee that the best feature identified for inclusion in creating a set of n features should exist in the best set of $(n + 1)$ features. The advantage is that it executes significantly faster than computing the performance of every possible feature set.

2.5.2. Overview of N-Fold Cross Validation

Often there exists a significant difference between the models' performance on its training data and future performance on real data. This is due to the algorithms' tendency to learn the training data, not the rules and correlation behind the data.

To mitigate the effects of models not being able to perform in real data tasks, a technique called cross validation (Kohavi, 1995) is used. In cross validation a portion of the training set is not used in the creation of the classifier. It is instead used to evaluate the performance of the classifier. That is, the performance is taken from a portion of the data the classifier has not seen before.

A more rigorous form of cross validation is known as N-fold cross-validation. In this method the training data is divided into N subsamples. Of the N subsamples, one is retained for measuring the performance (validation) of the model, and the remaining $N - 1$ subsample sets are used to train the model. The process is repeated N times such that each subgroup has been used as the validation set. The average performance is then calculated to determine the efficacy of a classifier technique for a particular data set.

Most commonly 10-fold cross validation ($N=10$) is employed when validating classification models. From experience, many researchers consider $N=10$ as "about right" as it often produces accurate predictions of classifier performance on a broad range of classifiers on a broad range of datasets. More rigorous testing by Bengio and Grandvalet (2004) has provided validation for $N=10$ as a good general solution. Another research effort by Markatou and Tian (2006) shows $N=10$ as a suitable validation technique for data relating to Biomedical Informatics.

2.6 Conclusion

In this section we presented an overview of some subject areas which provide essential concepts throughout this work:

- What emotions and affective states are;

- The cultural and natural components of emotion;
- How we organise, categorise and quantify emotions for research purposes;
- The computational means by which we perform classification.

This work also used many concepts from computer science, signal processing, psychology, physiology, human biology and neurology. These concepts are introduced and explained within the relevant sections as needed. A glossary is provided in Chapter 13 to assist the reader with the multi-disciplinary terms and jargon used in this work.

3.0 A Review of Current Literature

"Not everything that can be counted counts, and not everything that counts can be counted."

- Albert Einstein (1879-1955)

In this chapter we cover a range of topics that relate to the task of Physiological Pattern Recognition (PPR) to classify human emotion.

The chapter starts with an overview of different techniques used to recognise emotions in humans, so as to place where PPR exists in the scope of available techniques and why it is important. In general there are still many challenges to be overcome in the field of PPR (Picard, 2000), (van den Broek, Janssen, Westerink, & Healey, 2009). However PPR does offer practical advantages over other techniques that are also covered in this section.

A section is then dedicated to an argument in Emotion Theory over whether emotions are natural phenomena that we are born with, or the product of Social Constructionism (Averill, 1985), or a mixture of both. We would expect that if an emotion was in fact the product of Social Constructionism, then it would not necessarily have a common physiological pattern amongst multiple people.

After this background is established we examine the available literature describing how emotion will alter human physiological activity and the resulting signals collected. Eleven different physiological signals often studied in relation to emotion are then examined in detail.

A major factor in performing PPR based research is the validity of the emotion induced in the participants being studied (van den Broek et al., 2009). To this end we dedicated a section to examining the available literature on eliciting human emotion.

Lastly we conclude the chapter with a review of literature concerning works similar to our own, discussing their results and examining where useful contributions could be made. Absent from this chapter is the important role of the human face in emotion; this topic is covered separately in Chapters 4 and 5.

3.1 Recognition of Emotion

In order to rationalise a method for observing emotion, when no clear definition for what an emotion is exists, we utilise the following principle (our own wording) to generalise human emotion as a function of cognition, physiology and behaviour.

Emotion (whatever it is) is reflected in changes to a person's cognitive and physiological state. In turn, a relationship exists between a person's behaviour and their emotional state.

In humans, emotions will create alterations to the cognitive and physical state. These changes can be apparent (an expression of emotion) or discreet (a subtle change in state or behaviour). Expanding on a table presented by Picard (1997, page 27), Table 1 shows the known techniques by which machines can examine the human cognitive and physical state to derive information on the related emotional state.

Table 1: Cues for the Recognition of Emotion

Physiological	
Auditory	
• Speech Analysis	(apparent & discrete)
Visual	
• Face Recognition	(apparent)
• Gesture Recognition	(apparent)
Physiological Signals	
• Muscular	(discrete)
• Glandular	(discrete)
• Temperature	(discrete)
Cognitive	
EEG	(discrete)
MRI	(discrete)
Behavioural	
Interface Usage Data	(apparent & discrete)
Natural Language Processing	(apparent)

The distinction between analysing emotion from a physiological and a cognitive perspective is important. Cognitive processes are direct measures of brain activity, whereas physiological processes influence, and manifest from, cognitive processes.

There is a great deal of data sets available in emotion detection research. The focus of this work (shown in Figure 14) is with instrumentation which collects data from physiological processes (in blue) as opposed to cognitive processes (in red), or behavioural cues (conscious and deliberate actions).

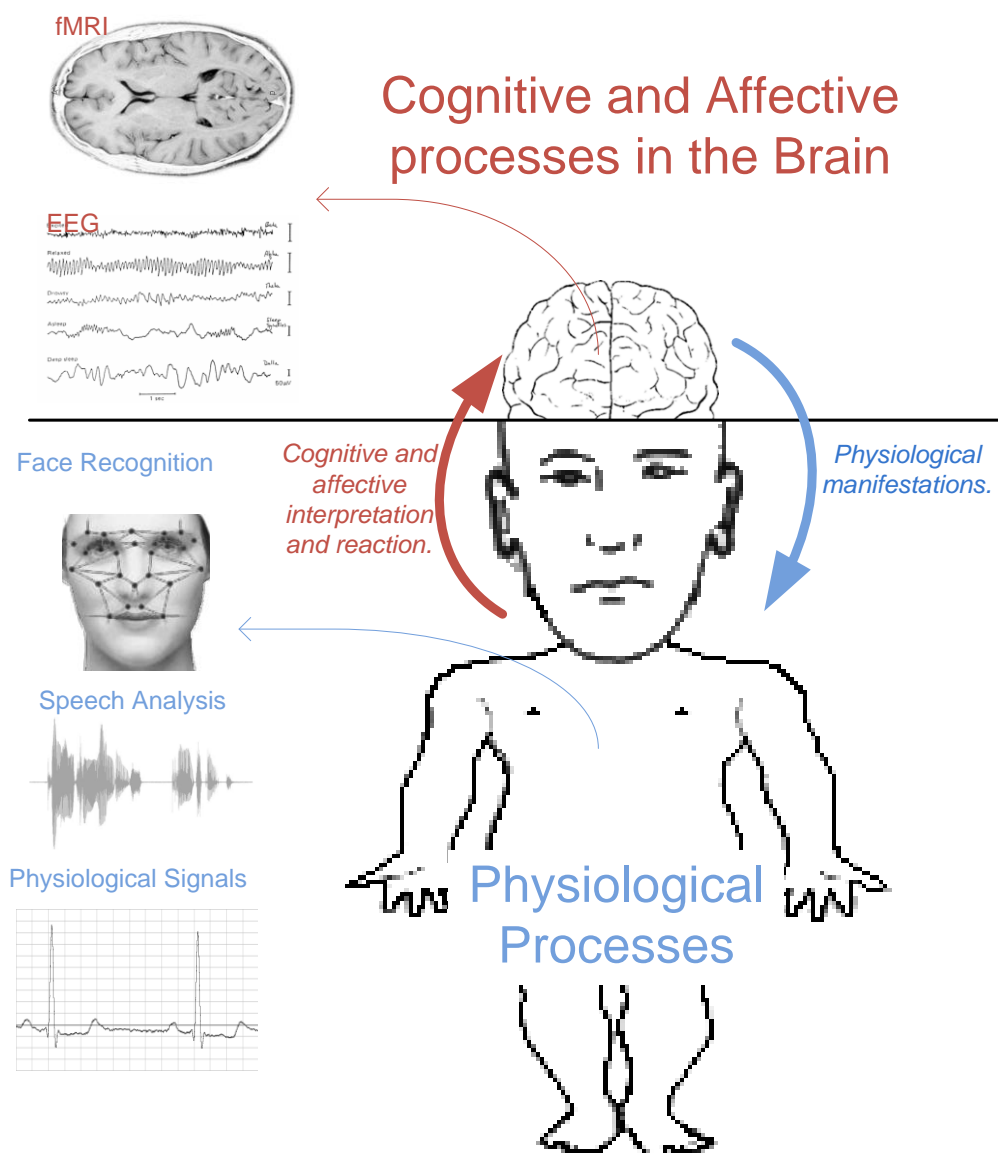

Figure 14: Physiological (blue) and Cognitive (red) signals.

3.2 Culturally Specific Emotions and the Plausibility of Heterogeneous Physiological Pattern Recognition

Theories on origin of emotions are often in the vein of social constructionism (emotions result from social concepts) or naturalism (emotions are a universal phenomenon), as discussed in section 2.2.

The extent to which Physiological Pattern Recognition can develop into a strong and broadly applicable technology is tightly linked to how these competing theories play out. If emotions are innate then we can hope to generally recognise them in people. However if social constructionism is the case, heterogeneous PPR becomes less plausible as there are few, if any, mechanisms by which people will gain a generic, and common, physiological response to learned emotions.

While many emotions appear universally, some emotions are considered exemplars of culturally specific occurrences. Extensive reviews of these emotions have been conducted by notable researchers such as Prof Jesse Prinz (Prinz, 2004) and Prof James Russell (Russell, 1991). These works identified many culturally specific emotions.

In assessing the likelihood and extent to which Social Constructionism influences human emotion, we researched a set of emotions commonly identified by Prinz or Russell as being culturally specific. For the purposes of gaining further understanding into the area we created, or found, existing counter arguments to each of the claims that these emotions were culturally specific. Summarising the results we were able to categorise arguments against social constructionism into four categories:

- a) The unusual assignment of an emotion to an event which invokes an extremely different emotion in other cultures. Seen as a different emotion altogether, not as a different response by outside observers.
- b) Cultural pride; one culture will often claim significant culturally important feelings as being their own distinct feeling, different from similar emotions in

to other cultures. This becomes a cultural identity and is kept as an important distinguishing characteristic.

- c) A language simply lacks the vocabulary to present an emotional state as one word. It is posited that this may commonly happen in cases where theorem b exists; as the feeling is often discussed, appropriate words naturally evolve for feelings that may not warrant a single word in other cultures.
- d) Some emotions, though universal, cannot be experienced unless the necessary experiences are encountered. Some "necessary experiences" are not equally encountered in different cultures. For example, few people in first world countries would experience emotions relating to desperate hunger, war, or experience feelings brought about by hunting or living with nature.

Examples of applying our counter arguments are as follows:

- Gezellig (the Netherlands) A cozy and inclusive setting or atmosphere. Similar to the German word Gemütlich;
 - Counter argument (Theory B), similar European concepts exist e.g. the Swedish word gemytligt, Danish word hygge, Norwegian word koselig, Russian, word уют, Czech word pohoda. However, the Dutch hold Gezellig to be one of their most important words, as it describes the ideal cultural setting.
- Liget (Ilongot people) (Rosaldo 1980 cited in Prinz 147) A manifestation of Anger, Passion and a will to act. Can inspire headhunting expeditions, or be felt before food hunting;
 - Counter argument (Theory B): The word is a central part of the very rich and interesting Ilongot social identity discussed at length by Rosaldo (1980) who discusses some quite inspirational field work she conducted amongst head hunting tribes of the Philippines. The emotion seems similar to that which occurs in many passionate young men in response to a grievous affront or an imminent hostile situation.

- Schadenfreude (Germany): A pleasure triggered by seeing the misfortunes of others;
 - Counter argument (Theroy C): English, for example, used to have the word "epicharikaky", which is defined by the compound *epi* (upon), *chaira* (joy/charity/heart), and *kakon* (evil) (Bailey, 1756). However the phrase "morose delectation" has also been used to describe a similar emotion, and was traditionally taught to be a sin by the Catholic Church (Hammond & Fell, 1847). In modern times, western cultures often borrow the word Schadenfreude to describe the emotion; which is prevalent in many western cartoons and sitcoms. Most notably the character Nelson Muntz from the Simpsons (Groening & Brooks, 2006) has turned a schadenfreude based phrase, "Haa-Haa", into a cultural meme, as per Figure 15.



Figure 15: Depiction of schadenfreude, in the Simpsons character Nelson Muntz (Groening & Brooks, 2006)

- Acedia (circa Middle Ages Europe): Aversion to religious imagery, arising from boredom induced by the repetitive nature of worship, (Prinz 2004, p 148);
 - Counter argument (Theroy d): Modern religions which require less time to be spent worshipping, combined with a change of religious practices may have removed the needed stimulating events.
- Awumbuk (Baining of Papua New Guinea): Sadness, tiredness or boredom caused by the departure of visiting friends or relatives, (Russell 1991, p 432);
 - Counter argument (Theroy c): A common feeling, but not one people would look to put a word to.

- Nginyiwarrarringu (Pintupi Aborigines of the Western Australia): A sudden fear that leads one to investigate its cause, (Russell 1991: 431);
 - Counter argument (Theroy d): If I may draw from personal anecdotal evidence. The author of this work knows the West Australian bush well, and has spent a lot of time (500+ days) walking through it. The author can testify to an (occasional) distinct and strong emotion similar (but separate) to fear that causes one to suspect an area, and want to investigate it. However, the author is not of the Pintupi or a related culture and would assume the emotion is caused by the nature of certain areas of the land, as the author has not felt it while trekking in any other part of the world (or even Eastern parts of Australia).

While we do not presume that this set of counter arguments can be taken as a significant challenge to the theory of Social Constructionism, we feel that this forms a framework for proceeding under the assumption that the effects of Social Constructionism do not heavily influence the “common” emotional states which we would wish to study in relation to Human Computer Interaction.

A logical framework for dealing with the competing theories of Naturalism and Social Constructionism was presented by Prinz (2004). This often cited compromise between nativism and social constructionism is achieved by allowing for different perceived states, both innate and culturally specific / learned states, to count as emotions. Prinz (2004) explains this is possible because we can learn to associate new contexts with specific body states. These cognitive-emotion hybrids are a logical solution to the arguments.

3.3 Physiological Changes as Cues for Recognition of Emotion

A significant (and somewhat pioneering) effort into detecting the human emotional state was undertaken by Rosalind Picard and her team at the MIT Media Lab (Picard, Vyzas, & Healey, 2001). This work used a (single) trained actor who purposely elicited emotional states while hooked up to multiple physiological recording devices.

Two significant findings from this work have told us a lot about the nature of understanding physiological changes resulting from changes in emotional state, namely:

1. Physiological changes for the same emotions in the same person will vary, however the variance has short term (one day) clustering whereby features collected on the same day are more clustered and predictable than features collected on different days;
2. Obtaining quality data in this field is an extremely difficult procedure.

Picard suggests three factors which can cause the day dependence of data and suggests a method of compensating using a day dependence matrix. The factors were:

- Skin sensor interface changes:
 - Changes in skin cleanliness (or washing);
 - Use of different amounts of gel;
 - Minor changes in positioning of sensors.
- Non-emotional factors causing alterations in physiology:
 - Caffeine;
 - Sugar;
 - Sleep;
 - Hormones.
- Mood and emotional factors altering physiology:
 - Feeling sad may make happy emotions/signals less distinct;
 - An exciting day may cause increased heart-rates.

The day dependence matrix proposed by Picard et, al. functioned by utilising an extra dimension for data for every day and projecting all days back into the original dimensional space. This procedure is best explained by example (see Figure 16);

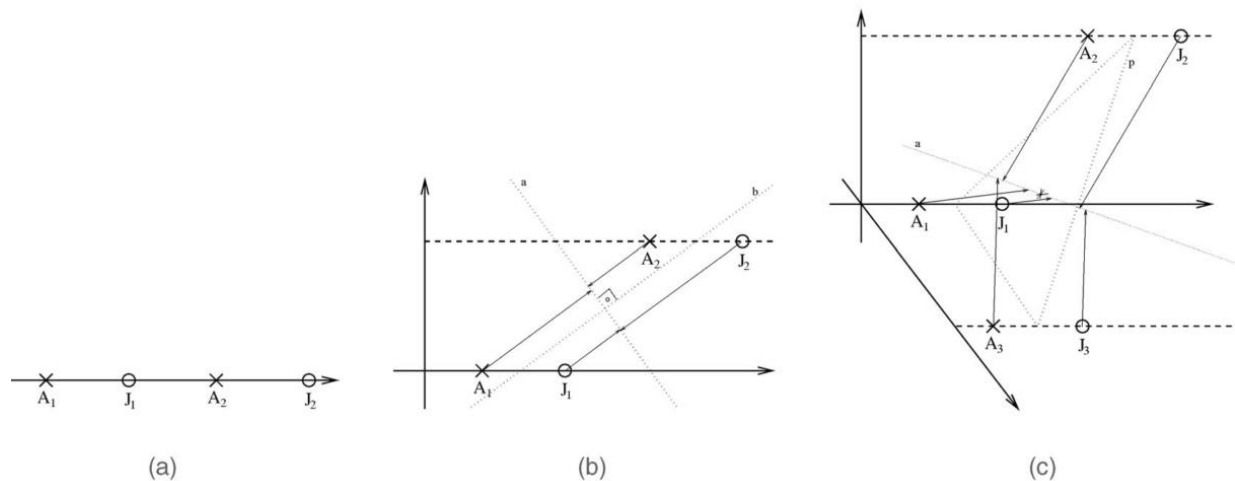

Figure 16: Dimensional projection via a day dependence matrix (Picard, Vyzas, & Healey, 2001)

If a feature for anger and joy for day one (A_1, J_1) and a similar set of features for day two (A_2, J_2) do not form groups as in Figure 16a; then results from day 2 are moved into another dimension Figure 16b. In this new dimensional space, a line (or n -dimensional plane as dimensions increase) can be constructed which separates anger (A_1, A_2) data from joy data (J_1, J_2). All data are then projected to line a to form a final feature set. In the case of higher dimensions an n -dimensional plane is constructed that separates all points. Figure 16c illustrates this for three days (hence three dimensions) using plane p . Plane p is shown as a triangle, where the vertices define the plane (by 3 points) and each point is placed to separate the data in its dimension. Finally all data can be transformed back to the orthogonal line a to create the final data set.

The day dependence matrix gives us a somewhat tenuous ability to reproduce results for one person over several sessions, thus strengthening the validity of Physiological Pattern Recognition (PPR) as a tool for prediction of affective states or emotions.

3.3.1. Physiological Pattern Recognition

Physiological signals are recordings taken of the human physiological state using various sensors. In the field of affective science physiological signals are recorded for various human systems, typically involving the:

- Muscular system;
- Subconscious actions;
- Cardiovascular system;

- Respiratory system;
- Dermatological system;
- Thermoregulatory system.

The Muscular System is inspected via a process known as electromyography. Electromyography detects the electrical potential generated by muscle cells when they contract.

Emotionally relevant subconscious actions such as pupil dilation (Bradley, Miccoli, Escrig, & Lang, 2008; Partala & Surakka, 2003; Siegle, Steinhauer, Carter, Ramel, & Thase, 2003; Jing Zhai & Barreto, 2006a), blinking (Vrana, 1995; Vrana, Spence, & Lang, 1988), posture (Coulson, 2004; Duclos et al., 1989; Riskind & Gotay, 1982; Wallbott, 1998) and pressure applied to objects (Clynes, 1989; Hama & Tsuda, 1990) are often linked with emotional state. These actions can be obtained via electromyography, video recordings and pressure sensors.

The human cardiovascular and respiratory systems are both regulated by the medulla oblongata (Amoroso, Bell, & Rosenberg, 1954; Guyenet, 1990). A close relationship exists between the affective cognitive state and how these systems are controlled and these systems are a major focus of current research. Respiration rates can be monitored with respiration sensors and the cardiovascular system is often examined through the electrocardiograph and blood volume pulse measurements.

The dermatological system has been shown to exhibit interesting (though complex) properties in relation to the human emotional state (Kepecs, Milton, & Brunner, 1951; Khalifa, Isabelle, Jean-Pierre, & Manon, 2002; Mittelman, Wolff, & Harold, 1943). The ease of obtaining skin conductance signals and the low cost of the electronics involved promotes the signals as being very useful to analyse.

The thermoregulatory system is often examined in terms of skin temperature (e.g. (Mittelman & Wolff, 1939) & (Lisetti & Nasoz, 2006)). Recordings are often obtained using a high precision digital thermometer.

3.3.2. **An Investigation of Physiological Signals**

As a large body of this work is concerned with the processing of physiological signals, it is necessary to arrive at an understanding of different signals that can be acquired from the human body in a context of their related functions and previously found uses in various fields.

For the purposes of this work it is necessary to investigate signals that are produced by areas of the human body thought to undergo physiological change during emotional state change. As such, we have attempted to identify and classify pertinent signals in an infrastructure that relates the various physiological signals to a mapping of their connectivity to different parts of the brain.

The rationale behind this classification comes from the emerging field of “cognitive neuroscience of emotion” (also called affective neuroscience) as proposed by Lane & Nadel (Lane & Nadel, 2000). The foundation of this field is that different parts of the brain are active or involved with different emotional states. Often the same areas of the brain are related to physiological mechanisms and it can be expected that signals collected in relation to those mechanisms may provide insight into the nature of the emotional state of the brain.

There has been much research into the areas of the brain involved with emotion. The field was pioneered in the 1870's by renowned French anatomist Pierre Broca (Broca, 1878), who discovered that there is a relationship between emotions and the limbic system of the brain. A thorough review of modern research into affective neuroscience by Dalgleish (2004) identified MacLean's (MacLean, 1952) limbic system theory of emotion as the dominant conceptualisation of the “emotional brain”. MacLean's and Dalgleish suggest the following areas of the brain as being most involved with emotion (Refer to Figure 17):

- Amygdala (part of the limbic system);
- Anterior cingulate cortex;
- Cerebellum;
- Insula cortex;
- Prefrontal cortex;

- Ventral striatum.

It is also important to consider the role of the medulla oblongata in the body's physiological state. Many physiological conditions, related to emotions, are regulated by the medulla oblongata. Many autonomic functions governed by this structure are both measurable and relate to emotion in some way; e.g. the heart rate, blood flow, respiration rate, perspiration, salivation levels, pupil dilation, micturition and sexual arousal.

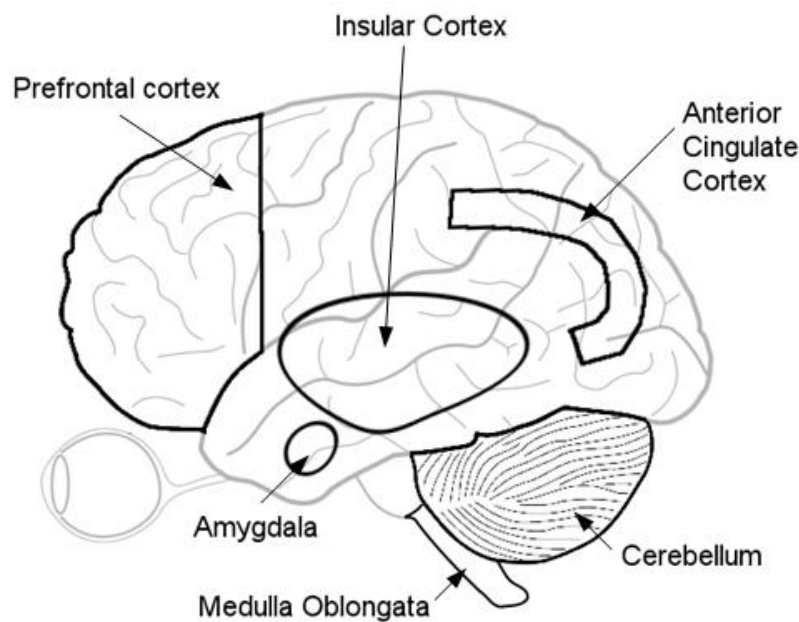

Figure 17: Structures of the brain involved in emotion.

3.3.3. Examining and Monitoring the Physiological State

The human physiological state is a system which responds to many variables in a way that, is thought to, vary from person to person (a good discussion of the topic is presented by Leidelmeijer (1991)). It is unrealistic to expect that we can obtain a clear picture of a person's affective state simply by examining a snapshot of someone's physiological recordings. However given prior knowledge of how an individual responds and making allowances for changes in how they respond (Picard et al., 2001) it is possible to perform emotional state recognition with varied degrees of success.

Finding correlations between the emotional state and the physiological state is difficult because many other factors influence the emotional state. However by controlling all other factors and changing only the emotional state (the control variable) a picture of how emotion influences the physiological state can be found.

Figure 18 shows the different factors that can influence a person's physiological state. Also shown are two distinct links between the cognitive state and the physiological state, which represent the conscious and sub-conscious (emotional) influences.

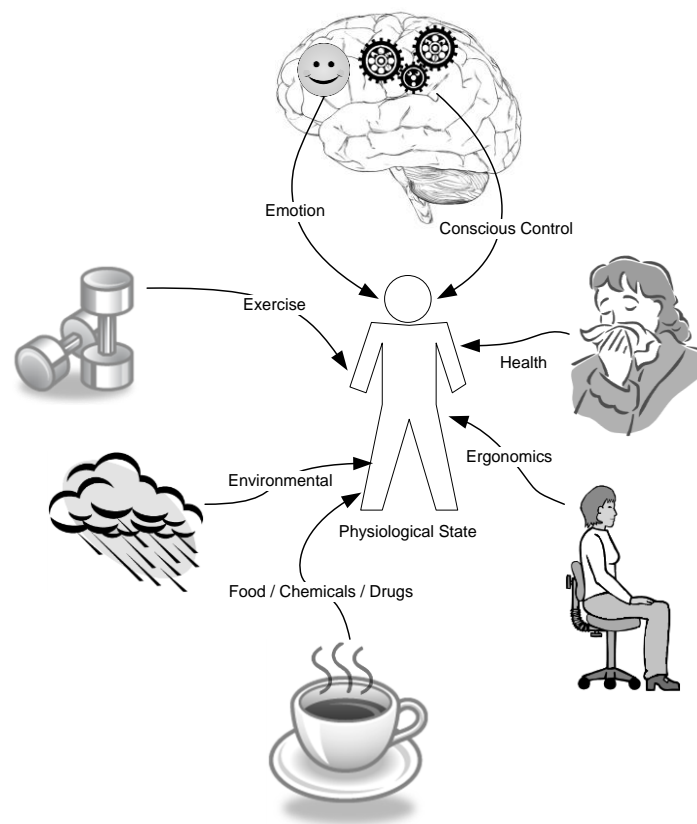

Figure 18: Variables Affecting the Physiological State.

3.3.4. Muscular Physiological Signals (EMG) of the Back (Posture & Support)

It is generally known that people display their emotional state through body language (Lowen, 1978) and that body language plays an important part in social interaction (Scheflen, 1972). A major component of body language is posture, which can easily be monitored via EMG analysis (Cram, Kasman, & Holtz, 1998).

Two lesser generally known links between posture/body language and emotion exist that are of interest. Firstly, body language cannot be thought of as a minor factor in the human emotional system. The human brain automatically perceives and understands whole-body signals (Gelder, 2006), which means from a neurological perspective they function in a similar manner to facial expressions.

Secondly, it is also known that back posture influences affective processing, for example Wilson (2004) found that 92% (n=24) of his participants were more successful in generating positive thoughts when in an upright position while attempting positive and negative thought generation tasks.

While the upper back plays a major part in human body language that can be readily accessed via EMG, there also exists affective traits expressed in the EMG of the lower back while in a sitting position. An interesting study by John Burns (Burns, 2006), showed that there exists a specific EMG activity related to tensing of the lower back muscles that is linked to anger.

The collection of EMG signals from the back for use in emotion classification tasks is an active field of research with notable publications including (Azevedo & Volchan, 2005), (Facchinetti, Imbiriba, & Azevedo, 2006) and (Hillman, Rosengren, & Smith, 2004).

3.3.5. **Human Action of the Hand (Pressure)**

There is a common perception that a frustrated person will subconsciously exert more force when performing simple motor activity tasks. This concept has been explored in some devices. A pressure sensitive phone handle developed by Scheirer (Scheirer & Picard, 1999) and detailed further in (Picard, 2000) predicts a user's mood by monitoring the pressure with which the phone is held. The system is shown in Figure 19. The screen shows a colour related to the amount of pressure exerted.

Hand pressure has also been linked to the cognitive load a person is under (Ikehara & Crosby, 2005). Other studies have found links between the level of Arousal

experienced by video game players and force exerted on gamepad buttons (Sykes & Brown, 2003).



Figure 19: The "TouchPhone"

3.3.6. Human Action of the Torso (Posture)

Posture is a primary mechanism through which emotion is communicated between people which can be examined via physiological EMG recording (Poppen & Maurer, 1982). It has been found that there are minor cultural specific factors (Kleinsmith, De Silva, & Bianchi-Berthouze, 2006) concerning how emotion is expressed through posture.

Attesting to a basic neurological (not cultural) connection between emotion and posture, is evidence of subconscious body posture recognition in people with cortical blindness (de Gelder & Hadjikhani, 2006). This effect is part of a condition known as "affective blindsight" (de Gelder, Vroomen, Pourtois, & Weiskrantz, 1999), where damage to the occipital cortex causes blindness but other brain pathways associated with processing emotion continue to receive visual information, and process it on a sub-conscious level.

3.3.7. Human Autonomous Functions Controlled by the Medulla Oblongata and the Autonomic Nervous System - Overview

The medulla oblongata (lower half of the brain stem) controls many autonomic functions, and relays nerve signals between the brain and spinal cord. It is not associated with many affective processes.

The medulla oblongata controls the following autonomic functions:

- Respiratory functions;
- Cardiac functions;
- Vasomotor functions (alterations in blood vessel diameter);
- Vomiting reflex;
- Coughing reflex;
- Sneezing reflex;
- Swallowing reflex;
- Urinary /defecation control.

Some of these functions were ruled out as possible candidates for study. Urination, defecation and vomiting would not be tested under our experimental setup for ethical / procedural reasons. However involuntary urination, defecation and vomiting are often associated with fear. Working with US WWII military veterans ($n=300$, all male), Dollard (Dollard, 1943) found that under conditions of extreme fear, soldiers reported involuntary: urination (6%), defecation (5%) and vomiting ($< 1\%$).

The coughing reflex and sneezing reflex are too uncommon to be studied in short sessions and lack evidence to show emotional links.

The swallowing reflex is known to be linked to emotions and the rate of swallowing is modulated by the type of emotion experienced. A recent study by Ritz and Thöns (2006) showed both pleasantness and Arousal interacted to modulate swallowing rates. They further found that female participants swallowed more frequently for negative stimuli than neutral, and less frequently for positive stimuli than neutral.

The autonomic functions we have discussed so far are linked to emotion; however a more accurate look at the physiological effects of emotion is obtained by examining the Autonomic Nervous System (Standring & Gray, 2008). The Autonomic Nervous System is the control mechanism of human homeostasis, functioning largely below the level of consciousness, and is partly controlled by the Medulla Oblongata. This system is divided into the parasympathetic nervous system and sympathetic nervous system. The parasympathetic nervous system is largely responsible for functions of “resting and digesting”, while the sympathetic nervous system is largely responsible

for “flight or fight” type responses. It is the Autonomic Nervous System’s control of many vital organs and influence on Physiological Signals and its connections to resting and Fight or Flight action that makes it noteworthy at this point. A full layout of its functions is shown in Figure 20. Note how the skin’s sweat glands are special in that they have sympathetic connections, but no parasympathetic connections.

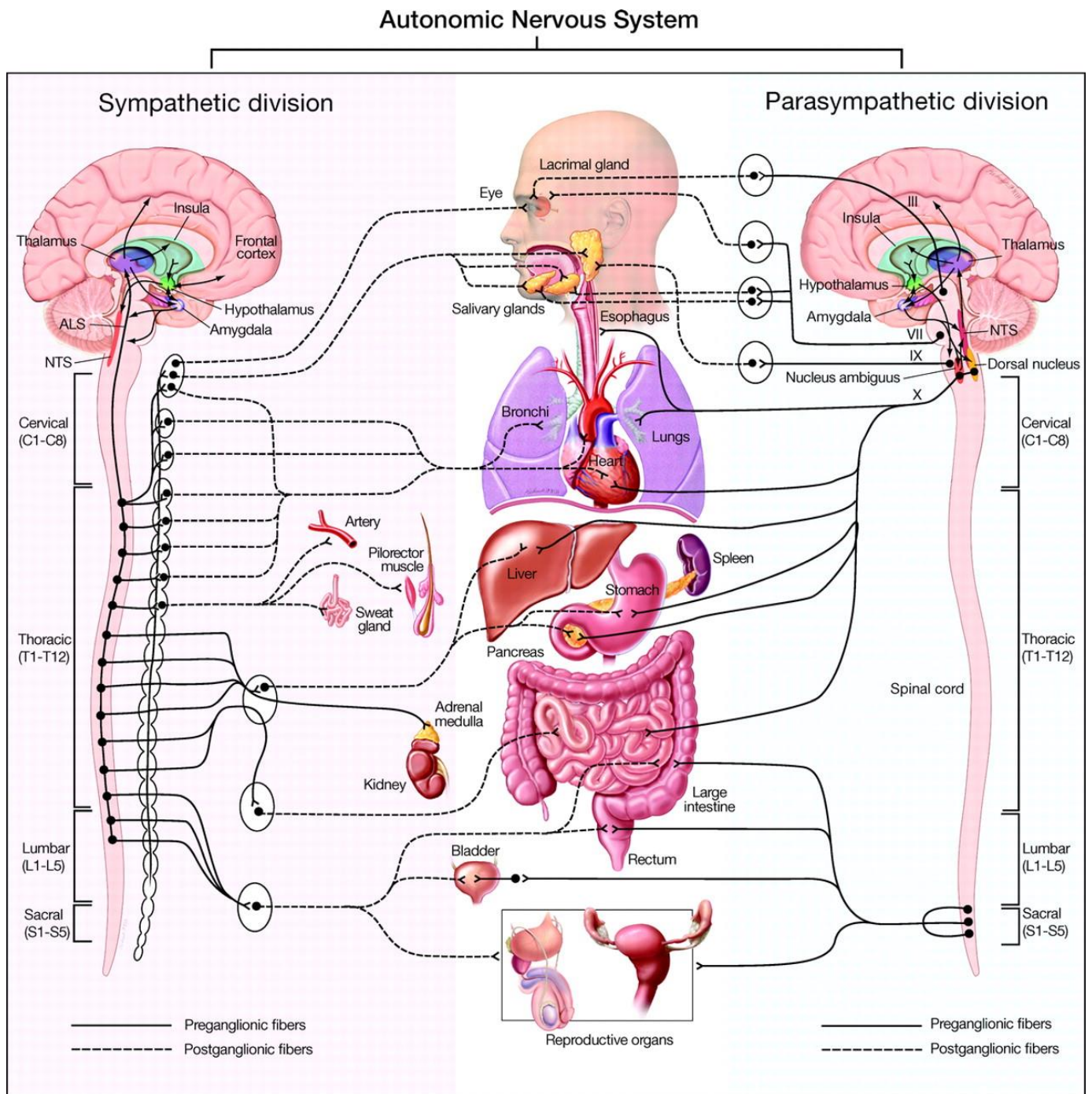

Figure 20: The Structure of the Autonomic Nervous System (Lane et al., 2009)

3.3.8. Signals Controlled by the Medulla Oblongata - Respiration

Respiration is a function of the human body that automatically adjusts to meet the body's physical and psychological demands. It is often studied in relation to emotion, however there is a belief, by some researchers, that much more research in this field is required. Grossman & Wientjes (2001) said:

"The investigation of respiration in relation to psychological phenomena remains one of the truly neglected areas of psychophysiology, behavioural medicine and neurophysiology. Respiration, of all major physiological processes, would appear to be, perhaps, the most obvious candidate to examine in association with psychological demands. Specific respiratory symptoms are frequently reported to emotionally stressful states"

A compilation of research on the matter of emotion and respiration has been compiled by Haruki, Homma and Umezawa (2001). From this book, it can be seen that the use of one or two chest bands that expand and contract with breathing, is the most common method used to digitise human respiration function. This type of sensor typically produces the waveform shown in Figure 21.

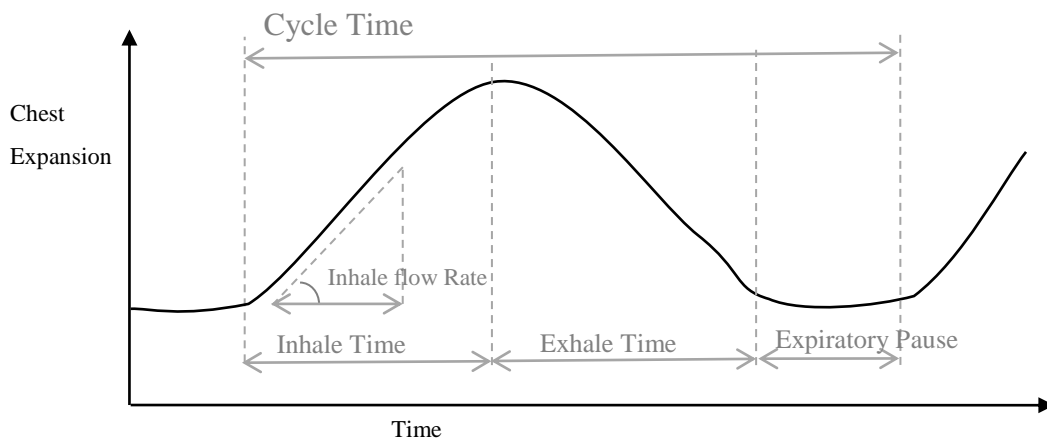

Figure 21: Respiration Cycle

The sensor is also easy to place, not prone to coming loose, and robust enough to be usable in real life situations. For this reason it is often used in experiments involving emotion during sports activities; e.g. Katsis et al., (2008) who used this sensor to perform emotion recognition in racing car drivers. This type of sensor may also be

incorporated into emotionally aware clothing (Axisa, Dittmar, Delhomme, & Cedex, 2003).

3.3.9. **Signals Controlled by the Medulla Oblongata- Heart Beat**

The “heart beat” is the cardiac cycle of the heart. It generates an arterial palpation that we refer to as the “pulse”. It also creates an audible noise, the result of the blood flow being affected by the closing of the heart valves. There is also an electrical signal created by the electrical activity of the heart known as the electrocardiogram (ECG) from the German Elektrokardiogramm (EKG). The sequencing of these signals is displayed in what is known as a Wiggers Diagram (named after eminent cardiovascular physiologist and 21st president of the American Physiological Society; Dr. Carl J. Wiggers) which is shown in Figure 22.

In practice the ECG (aka EKG) is the most practical of methods for studying physiological signals in relation to the heart beat. The signal is information rich and easily obtained via sensors placed on the skin surface.

The ECG is a periodic signal and is described by the ECG basic waveform (Dubin, 2000), also shown in Figure 22. The ECG can be analysed in terms of the P, Q, R, S, T and U waves. Generally referred to as the P-wave, QRS Complex, T-wave and the U-wave. The heart rate (pulse) is derived from the distance between R wave peaks (also called The R-R interval) by the equation $HR = 60/RR$ where the heart rate is in beats per minute and the RR interval is in seconds. Note: the U wave, not shown in Figure 22, is a very small wave following the T wave. As it is a very small wave it is often lost in the signal noise and thus not used in ECG analysis.

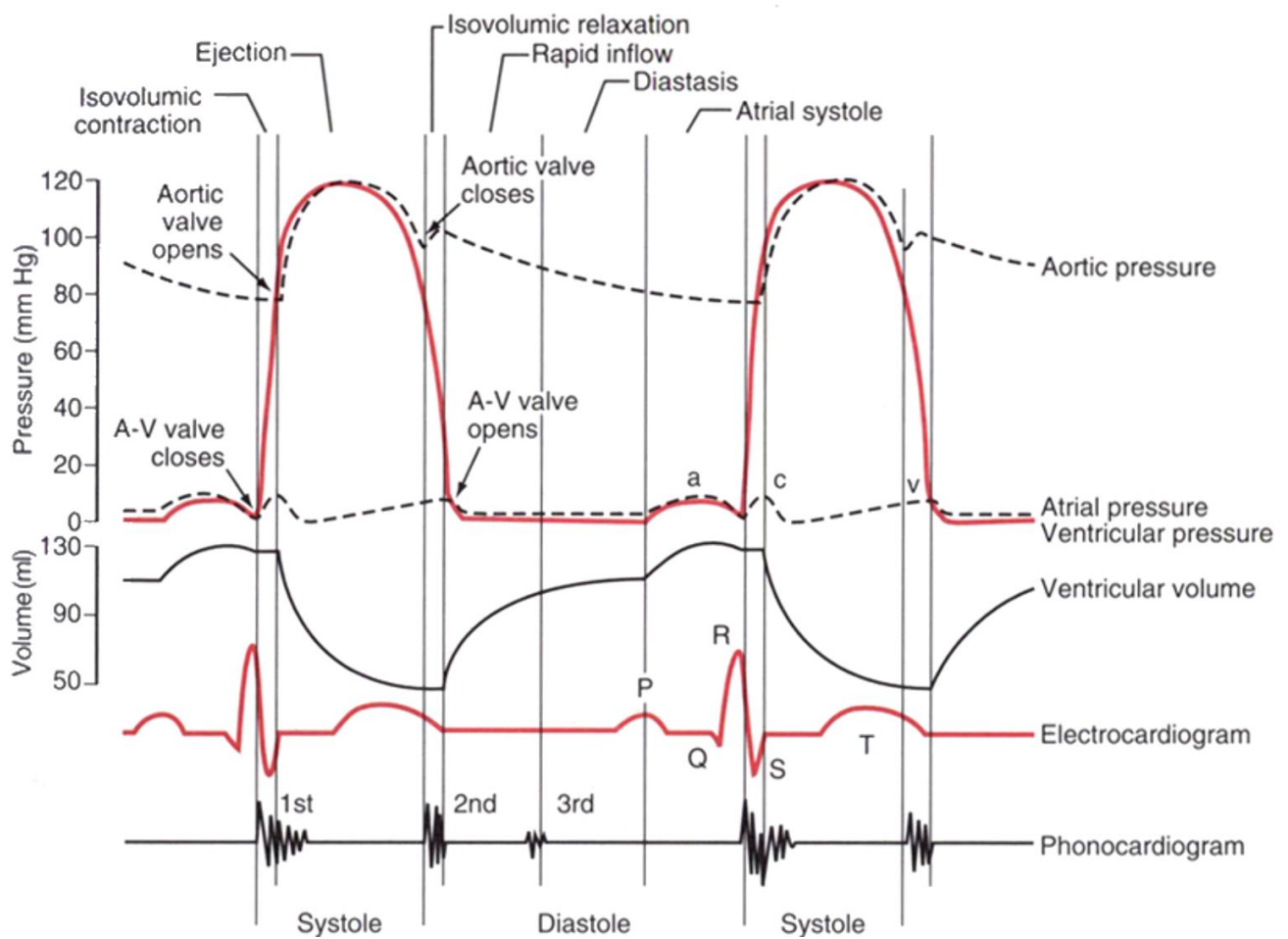

Figure 22: Wiggers Diagram, (Guyton, 2000) ; Chapter 9 - Page 99.

The ECG response to stress has been studied by Healey & Picard, (2000), who showed that simple ECG based metrics could be used to achieve stress detection at around 50% accuracy; or 88% accuracy when combined with other physiological signals.

The role of heart rate in relation to the emotional Valence has been studied at length by various authors. Libby, Lacey & Lacey (1973) graphed average heart rates for participants exposed to slides of varying degrees of pleasantness.

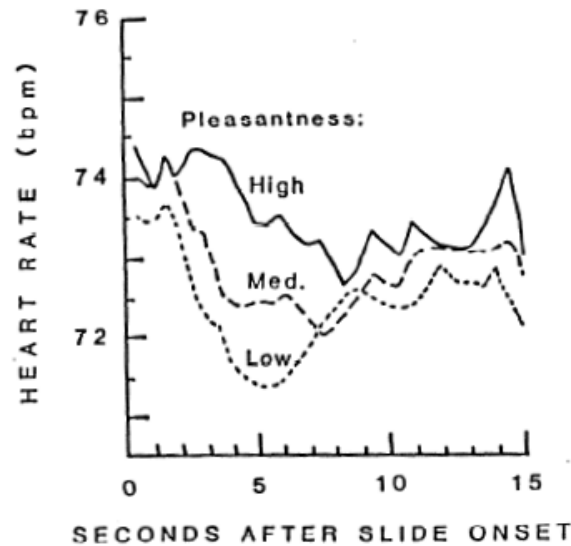

Figure 23: Heart Rate in Relation to Pleasant Emotions (Libby Jr et al., 1973)

Winton, Putnam & Krauss (1984) further examined the relationship of emotional Valence to heart rate and skin conductance. They found a set of changes over time profiles for five stimulus types, that is; peoples' heart rate changed in a similar manner for a similar stimulus. Their results are shown in Figure 24.

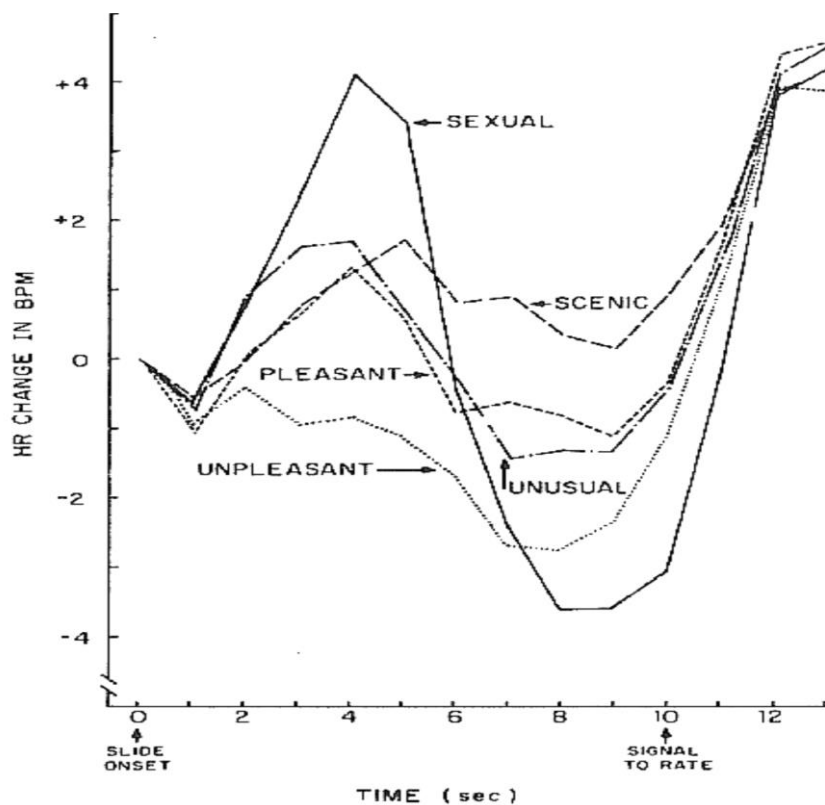

Figure 24: Heart rate response to various slide types

The ECG response to fear is different to the ECG response to many other negative stimuli. Globisch, Hamm, Esteves, and Ohman (1999) demonstrated this using images of spiders and snakes (generally considered negative stimuli) on participants that were phobic of these animals vs. participants who were not. The control participants responded to negative stimuli with a lowered heart rate, while the phobic participant's heart rate lowered for around one beat then began to increase sharply. A graph of these results is shown in Figure 25.

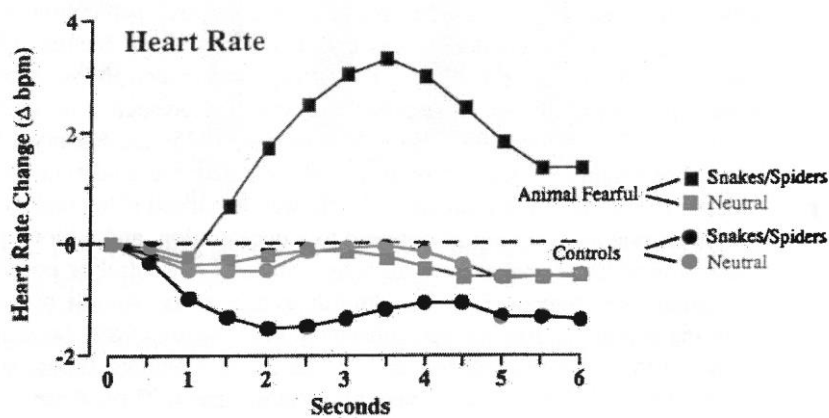

Figure 25: Heart rate in response to negative animal stimuli, in phobic and non phobic participants. (Globisch et al., 1999)

3.3.10. Signals Controlled by the Medulla Oblongata - Blood Volume Pulse

The Blood Volume Pulse (BVP) is a signal collected by a photoplethysmograph which takes a volumetric measurement of an organ or area of flesh. The device illuminates the skin and records the level of light absorption (Shelley & Shelley, 2001).

While the BVP is useful in revealing many of the attributes that knowledge of the heart rate can provide there is a piece of extra information available. It is known that the overall amplitude (envelope) of the BVP signal contracts when a person is startled, fearful or anxious (Picard, 1997, pg 162); likewise the amplitude increases when there is greater blood flow to the extremities, such as is caused by a person being relaxed. An example of this envelope is shown in Figure 26.

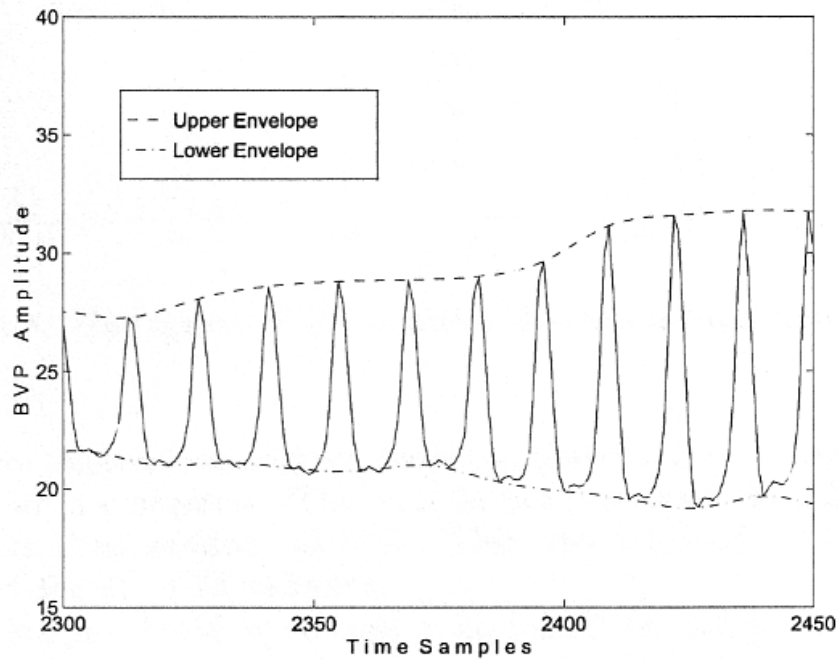

Figure 26: A BVP Envelope (Fernandez & Picard, 1998).

3.3.11. Human Autonomous Functions Controlled by the Medulla Oblongata -Blood Pressure

Blood pressure is a physiological metric measured by a sphygmomanometer. It is commonly associated with stress and studies such as Globisch et al., (1999) have shown definite usefulness as a signal in predicting stress. Their results show changes in blood pressure after three seconds of being exposed to a stress inducing stimulus (pictures of snakes and spiders). The response by people with a related phobia was extremely pronounced over other subjects, see Figure 27.

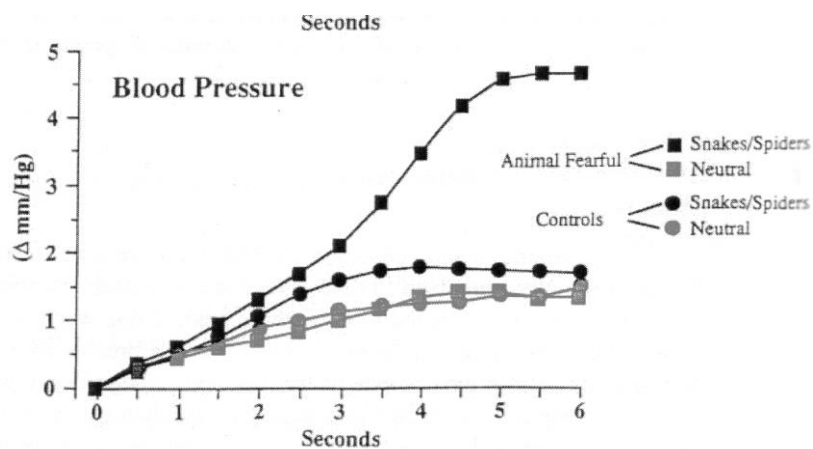

Figure 27: Blood Pressure in response to negative animal stimuli, in phobic and non phobic participants.

(Globisch et al., 1999)

3.3.12. Human Dermatological Response (Sweat & Skin Conductance)

Skin conductance is a physiological metric measured by a simple reading of electrical resistance of the skin, thus it is recorded by an ohmmeter. It is often referred to as Galvanic Skin Response (GSR), Electrodermal Response (EDR), Psycho Galvanic Reflex (PGR) or Skin Conductance Level (SCL).

Skin conductivity is one of the most robust and well studied physiological responses e.g. (Lee et al., 2005; Picard, 1997, 1997; Picard, 1997; Ryoo, Kim, & Lee, 2005; Scotti, Mauri, Cerutti, Mainardi, & Villamira, 2005a, 2005b, 2005c; Wagner, Kim, & Andre, 2005a, 2005b, 2005c; Zhai & Barreto, 2006a, 2006b). It is controlled by the sympathetic nervous system (Standring & Gray, 2008), see Figure 20, which changes the levels of sweat in the eccrine sweat glands. The eccrine sweat glands, located on the palms of the hands (and the soles of the feet), have been shown to be particularly responsive to emotional states, and only minimally responsible for thermoregulation (Michael, Dawson, Schell, & Fillion, 1990). Thus this signal is a good indicator of sympathetic nervous system action in relation to the fight or flight response.

The GSR has been shown to be linked to measures of startle, Arousal, stress and attention and other general emotional states (Critchley, Elliott, Mathias, & Dolan, 2000; Dhokalia & Atreya, 2011; Domingues, 2011; Elfering & Simone, 2011; Michael et al., 1990; Mundy-Castle & McKiever, 1953; Westerink, Broek, & Schut, 2008).

Globisch et al., (Globisch et al., 1999) has shown the GSR signal to be a useful indicator of stress levels. Their results show changes in blood pressure after three seconds of being exposed to a stress inducing stimulus (pictures of snakes and spiders). The response by people with a related phobia was pronounced over other subjects, see Figure 28.

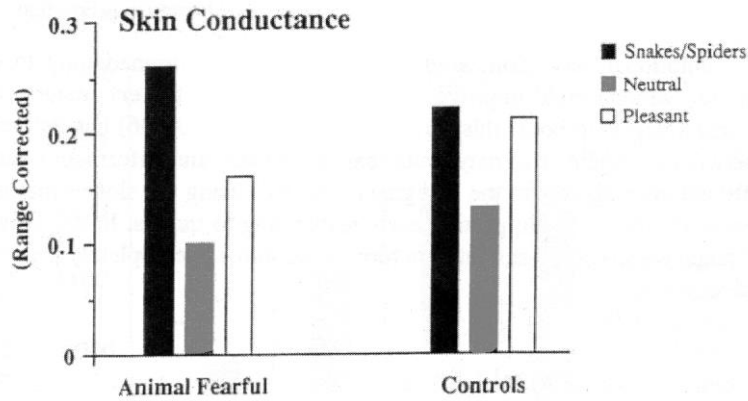

Figure 28: Skin Conductance in response to negative animal stimuli, in phobic and non phobic participants. (Globisch et al., 1999)

3.3.13. Human Thermoregulatory Response - Skin Temperature and the Insula Cortex

Many metaphors exist to describe emotions and emotional situations in terms of temperature, such as "an icy stare", "a cold heart", "the cold shoulder", "hot under the collar" and "radiating warmth and kindness".

Two well publicised studies by Williams & Bargh (2008) revealed how hand temperature affects the emotions (of undergraduate students). The researchers found that holding warm things may actually make people view others more favourably (in terms of social warmth), and having warm hands may also make people more generous. In the first study by Williams & Bargh, 41 participants were given hot or ice cold coffee and then asked what they thought of a stranger after a brief meeting. The participants holding a hot cup of coffee were more likely to judge the stranger to be a kinder person. The second study involved participants holding either a warm or cold object and participating in a farcical task. After the task was completed the participants were given a choice of reward for participating in the study: either a gift for a friend, or a reward for themselves. The people with who held the hot item were more likely to choose the gift for a friend reward.

Williams & Bargh concluded:

"Physical and psychological concepts are much more closely aligned in the mind than we have previously appreciated. Other research has found that the same brain region that processes physical temperature changes, called the insula, also processes feelings of trust and empathy associated with social warmth."

These studies appear to lack a baseline of a temperature control group to distinguish whether heat makes us more trusting and generous, or coldness induces greed and scepticism; or both.

3.3.14. **Sampling of Skin Temperature from the Hand**

Typically many researchers will measure skin temperature by use of a finger sensor. Notable works adopting this technique include Bela Mittelman & Wolff (1943), Baumgartner et al., (2006), Pasca, Pierre, & Henrique (2005) and Kim & Andre (2008). This however may be a flawed approach if the ramifications of the nature of this kind of measurement are not properly considered, as will now be discussed.

The human epidermis is an organ with a very large surface area (average 1.9m² in males, 1.6m² in females). The finger sensor takes a reading at one location of the epidermis which may account for 1cm² of data. Thus this one reading accounts for 0.005% of the measurable skin surface temperature and it is quite possible that if present a localised variation will greatly influence the results obtained by the sensor. Thus it is our feeling that a fundamental step in using the temperature sensor on a finger is determining what localised variations exist and to what extent they can influence the data.

Many variations are known to exist as the result of injury, sickness or chronic conditions. Figure 29 summarises some common conditions that alter skin temperature in the hands.

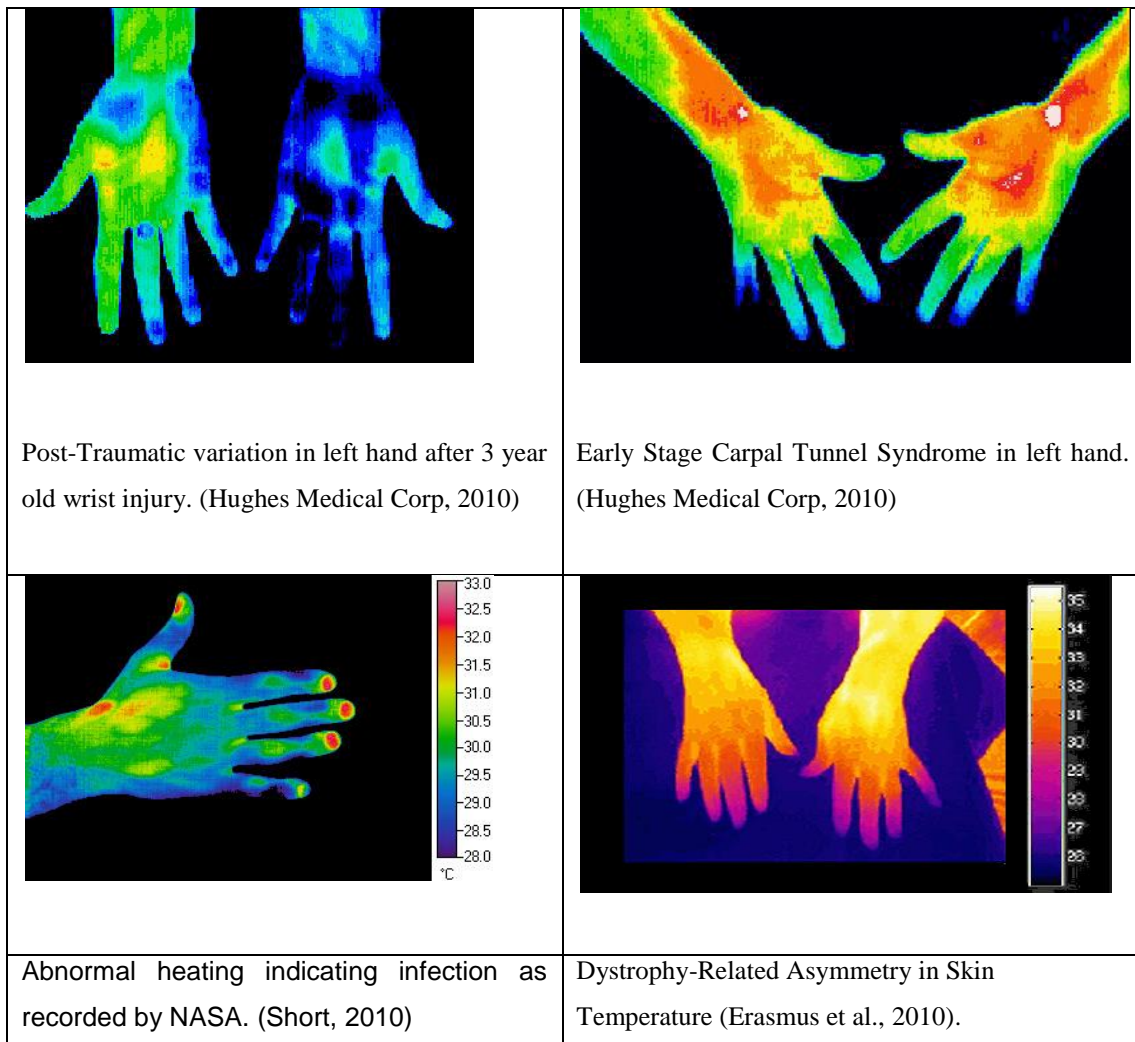

Figure 29: Medical conditions effecting skin temperature of the hands

It is clear from the images in Figure 29 that damaged hands have unique heat patterns. Regardless of sampling damaged or undamaged hands, samples taken from different parts of the hand will exhibit large variations of up to 4° Celsius.

In a study of 81 healthy volunteers, Kokubo, Taniguchi, Yamamot and Hirasawa (1998) made several important observations about the surface temperature of the human hand. By recording 2D temperature distributions of the participants during rest and analysing the data against age and gender, it was shown that in the sampled population:

- Females had an average temperature of 32.4° Celsius;
- Males had an average temperature of 31.8° Celsius;
- There was no correlation between age and temperature;

- Average temperatures across the hand differed 2-3 degrees (10% variation);
- The 2-dimensional distributions of all data can be classified into four groups:
 1. High temperature in the middle of the palm (C);
 2. High temperature at both thenar and hypothenar eminences (TH);
 3. Intermediate type (CT);
 4. Combination type (CTH).

The four temperature groups identified by Kokubo et al., are shown in Figure 30. These temperature groups are arguably caused by differences in the way the thermoregulatory system is regulating temperatures in those regions. As we would be taking finger temperature samples from one of four different temperature regulation groups, it would be logical to suggest that individual groups may exhibit different temperature responses to emotion. This introduces extra variables into the process that may not be present if an alternate area of skin was investigated.

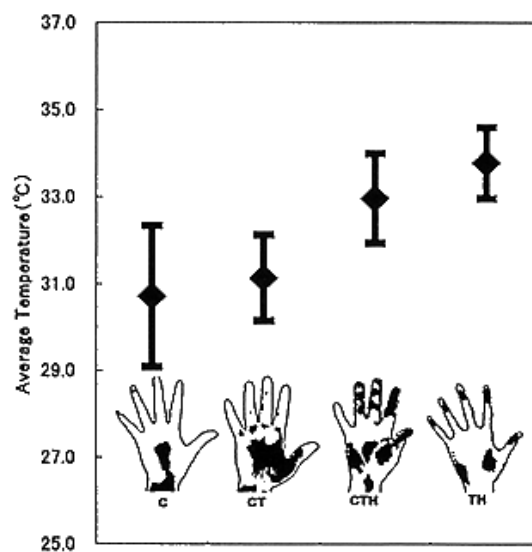

Figure 30: 4 Hand-temperature types identified by Kokubo et al., Dark regions indicate thermal hot spots of the four hand circulation types. Corresponding mean hand temperatures and deviations given above.

3.3.15. Skin Temperature and Environmental Factors

Common drugs such as nicotine, caffeine and alcohol have an effect on the skin temperature of the hands.

The nicotine in cigarette smoke is a known vasoconstrictor which causes the hands of smokers to become cooler. For a reference study see Usuki, Kanekura, Aradono and

Kanzaki (1998). It is hard to quantify the extent of the effect because of variations due to age and amount of nicotine absorbed. Until further research in this field is conducted we are making no assumptions, other than this is to be treated as yet another individual variation from one person to another. Alcohol is a known vasodilator and will cause hands to become warmer. Caffeine increases blood flow, which in turn increases the transfer of heat to the skin (Daniels et al., 1998), (P. Quinlan et al., 1997) & (Koot & Deurenberg, 1995).

3.3.16. Human Action of the Eye

Pupil dilatation in relation to emotional states has been controversial and prone to methodological issues. Major works in the field remain contradictory. Loewenfeld (1966) studied the effects of various sensory and psychological stimuli on pupil size and found no cause for pupil constriction. Hess (1972) found a continuous response, ranging from dilation to interesting or pleasing stimuli to constriction to unpleasant or distasteful material. Janisse (1974) was unable to reproduce all of Hess's results and challenged the findings claiming there was no pupil constriction to negative stimuli.

These experiments had methodological issues with the visual stimuli used as alterations in hue, luminance, and contrast, all effect pupil dilation (Hess & Petrovich, 1987).

Recent studies on pupil dilation in response to auditory stimulus, such as Partala & Surakka (2003), found affective responses involving both dilation and constriction over a period of time after emotional stimulus. Partala & Surakka summarised their findings as:

“First, there was a period of about 400ms without any pupil dilation, followed by a steep increase in the pupil size. The peaks were reached at about 2–3 s from the stimulus onset. Then a smooth constriction started and continued until the end of the stimuli. Just following the stimulus offset there seemed to be a small dilation, after which the constriction continued”

Averaged graphs for their findings are shown in Figure 31.

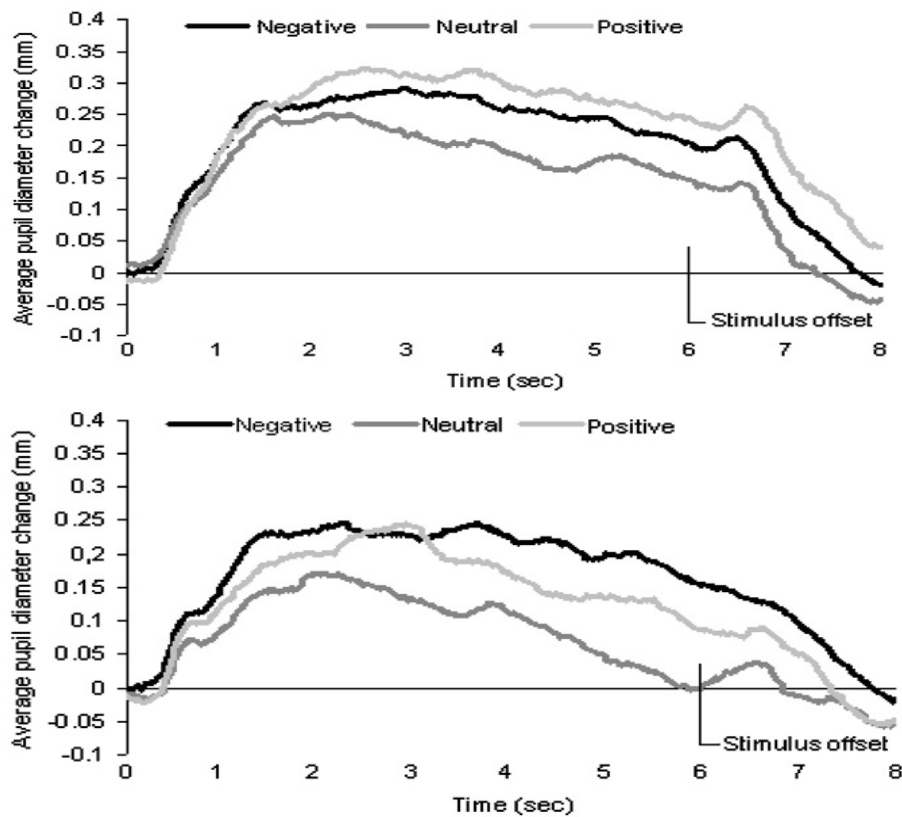

Figure 31: Averaged pupil diameter timelines for the different stimulus categories for female (above) and male (below). (Partala & Surakka, 2003)

While the nature of short term changes to pupil response are still being explored, the longer term (mean) pupil dilation is understood to be linked to the level of arousal, as reviewed by Granholm & Steinhauer (2004). Such tests are often successfully employed to evaluate a person's alertness or level of fatigue/tiredness e.g. Lowenstein, Feinberg, Loewenfeld (1963).

There are also actions of the extra-ocular muscles which relate to emotional states. It is commonly believed that increased blinking is often linked with nervousness, or any emotional state which makes a person averse to maintaining eye contact. Such information can be used in lie detection (Fukuda, 2001). It is also known that increasing the mental workload decreases the blink interval (Veltman, 1996).

Humans, like many other animals, must move their eyes to "see", as opposed to most birds which keep their eyes fixed while taking in a scene. Human eyes move around, locating interesting parts of the scene to construct a three-dimensional mental "map" of what is visible. There are many eye movements associated with human vision, which extend well beyond the scope of this work.

There is however one type of eye movement which has known emotional links and that is saccades. These saccades are quick, simultaneous movements of both eyes in the same direction. Their function is to allow small parts of a scene to be viewed with greater resolution. We have seen multiple works demonstrate changes in saccadic motion associated with processing fearful faces, e.g. (Pratt & West, 2009).

3.3.17. **Summary of Physiological Changes**

In this section we have summarised physiological signals known to have changes which correlate with the human emotional state. These changes are unreliable, easily affected by other bodily processes and external influences and potentially have characteristics specific to individuals.

The primary method used to overcome these problems is to use multiple physiological signals to increase the amount of “clues” available. This is advocated broadly and is well explained by Picard et al. (2001).

There are other techniques that can be used to address the challenges of analysing physiological signals, including:

- Finding other factors which affect the physiological signals and control or compensate for them;
- Create customised “profiles” for different individuals;
- Use baselines collected during emotionally neutral states to give physiological changes a Valence;
- Use adaptive systems that learn the participants physiological responses on the fly.

The last three of these points are techniques employed during analysis and classification tasks and are discussed later in this work. However in trying to understand physiological changes as cues for emotion recognition, it is important to get an overview of the other factors which affect the physiological signals and how it is possible to control or compensate for them.

3.4 Other Factors Affecting Physiological Signals

This section gives an overview of factors which affect human physiological signals. Some of the factors may only affect a signal's baseline, while others will alter how emotional states are reflected as changes in various signals.

We attempt to collect and create a set of experimental procedures to control these factors (where possible) and a related set of algorithms to compensate for these factors.

3.4.1. Common Drugs in Relation to Physiological Signals

Typically cigarettes (nicotine), alcohol and coffee (caffeine) are of concern when taking physiological signal recordings in an affective context; e.g. (Brosschot, Dijk, & Thayer, 2007). These substances to have some direct effects on the signals being recorded, such as alcohol increasing the ECG's QT interval (Zhang, Post, & Dalal, 2011). As well as effects on the signals these substances also affect emotional responses; one example being Rimm & Briddell (1981) who showed alcohol consumption reduced perceived anxiety caused by snake imagery.

Caffeine increases blood flow, which in turn increases the transfer of heat to the skin (Daniels, Mole, Shaffrath, & Stebbins, 1998), (Quinlan, Lane, & Aspinall, 1997) & (Koot & Deurenberg, 1995) and affects blood pressure (Daniels et al., 1998) as shown in Figure 32.

The nicotine in cigarette smoke is a known vasoconstrictor (Black & Huang, 2001) which causes the skin and hands of smokers to become cooler. However there is no apparent effect of key ECG metrics such as the QT interval (Zhang et al., 2011).

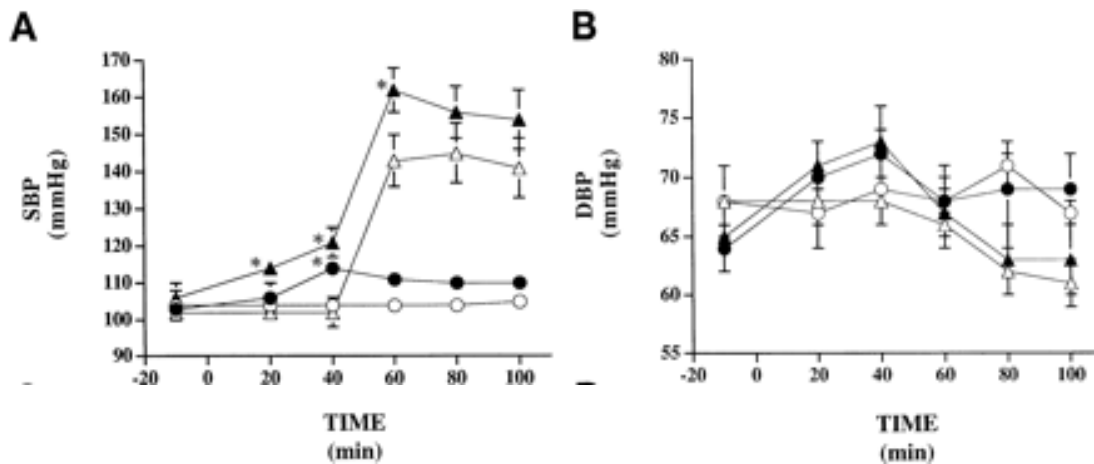

Figure 32: Mean changes in systolic blood pressure (SBP; A), diastolic blood pressure (DBP; B), mean arterial pressure (MAP; C), and heart rate (D) in response to ingestion of 6 mg/kg caffeine during rest and 65% maximal oxygen consumption. bpm, Beats/min. ○, Rest-placebo; ●, rest-caffeine; (Daniels et al., 1998)

3.5 Human Emotion as an Experimental Variable

At first human emotion seems a poor choice as an experimental variable. There is no accepted definition as to what an emotion is, nor is there an accepted list of emotions. Making an observation such as “the man felt homesick” become irrelevant if homesickness is later found not to be an emotion. Furthermore we have no device for measuring the extent of an emotion. For example after determining a person is feeling happy we have no direct way of determining how happy that person is.

To begin using emotion as an experimental variable, it is useful to decide whether to study emotions as described by discrete categories or as a continuous space over several dimensions. By doing this we can formulate experimental feedback procedures designed around the corresponding classification theory. In this work we shall use a continuous space over three dimensions. The rational and implementation of this is discussed later in Section 6.2.

To use emotions in our research we must devise some mechanism by which emotion can be controlled in our test subjects. As clearly demonstrated by Lang, Bradley, & Cuthbert (2001) and Bradley, Codispoti, Cuthbert, Lang, and Sabatinelli (2001) a procedure used to induce an emotion will not always be successful and even when successful will create a variable degree of that emotion. For instance we may attempt to make our subjects happy by informing them they have won a 100 dollar bill. This hypothetical scenario is likely to make most people happy and some people

suspicious. Of the people we have made happy some will be more pleased with this new fortune than others.

Emotion election is an extensively studied field, and there appears to be no way to predictably control a person's emotional state in a reliable manner. It can be said that our subjective response to events is the root of human "individualism". Major factors which individualise affective response to emotional stimulus include:

- Dispositional mood at the time of stimulation (Watson et al., 1988);
- Affective disorders in humans (and the high prevalence thereof) (Post, 2009);
 - A study by Sloan, Strauss, Quirk, & Sajatovic, (1997) showed that depressed people will report positive stimuli as less pleasant than non-depressed individuals. While there is no statistical difference in reporting of negative stimuli.
- Emotion regulatory styles (Gross, 1998);
- Emotional reactivity (Kagan & Snidman, 1999);
- Health and physical condition (Ritz & Steptoe, 2000), (Cacioppo, 2009);
 - Stress levels are of particular importance, (McEwen & Seeman, 2009).
- Personality, and personality traits (Larsen & Ketelaar, 1991), (Gross, Sutton, & Ketelaar, 1998) & (Davidson, Scherer, & Goldsmith, 2009);
- Meta-emotions (Salovey, Mayer, Goldman, Turvey, & Palfai, 1995);
- Demographic (Age, Gender, Class, Culture) (Vrana & Rollock, 2002) (Kemper, 2000);
 - Age: It has been shown by Lawton, Kleban, Rajagopal and Dean (1992) that it is useful to divide a population into three age groups when considering affective response;
 - Gender: Wager and Phan (2003) present a good meta-analysis of different neuro-imaging studies done in the processing of Valence in different genders;
 - Class and Culture: has been shown by various studies to have significant influence on emotional response (Tsai, 1997), (Rozin, 2009), and (Mesquita, 2009).
- Social Process (Salovey, 2009), (Petty, Fabrigar, & Wegener, 2009) & (Leary, 2009).

Because of these factors, it is often necessary to assess our subject's emotional state during data collection and use the assessments, not the stimulus as an experimental variable. This also allows for a measurement of the degree of emotion present to be made. This approach has been widely advocated by prominent authors including Bradley and Lang (1994), Lang et al., (2001), Picard (1997) and Coan and Allen (2007)

3.5.1. **Influencing the Human Emotional State**

The task of influencing a human's emotional state for experimental work is difficult and many technical, ethical and practical considerations must be taken into account.

Previous research efforts can be categorised as using one of three main devices for influencing the human emotional state:

- Stimulating emotion in humans;
- Subjecting humans to tasks known to induce emotions;
- Having humans deliberately express emotions.

Stimulating Emotion in Humans

The stimulation of a human's emotion generally involves exposing the participant to some form of media or device known to induce an emotional response. Typically such stimulus will take the form of:

- Images;
- Literature;
- Movies / video;
- Music / sound;
- Some form of physical device.

Image based emotion stimulation, the form favoured by this research, is a very common and practical device with repeatable results. A popular set of images, known as the International Affective Picture System (IAPS) (Lang, Bradley, & Cuthbert, 1997) has been extensively studied [eg (Oliveira et al, 2006) (Surakka & Anttonen, 2005), (Bradley et al, 2001) & (Sloan et al., 1997)] and is recognised as the most

popular image based stimulus for experimental investigations of emotion and attention.

Literature as an emotional stimulus is extremely effective (Oatley, 1999), however as an experimental apparatus it is difficult to control as an experimental apparatus:

- It is difficult to record which part of the narrative is being read when;
- Stopping to evaluate the persons emotional state will disrupt the reading and result in loss of immersion.

While many studies of emotional experience involve literature e.g. (Brunyé, Ditman, Mahoney, & Taylor, 2011) & (Mar, Oatley, Djikic, & Mullin, 2010), the goals are often related to exploring literature. However there is growing usage of narrative in studies of emotion and attention eg (Williamson, Harpur, & Hare, 1991) & (Lewis, Critchley, Rotshtein, & Dolan, 2007). This type of research uses an experimental procedure where singular words or short texts can be used in a controlled manner to stimulate emotions. Two standardised sets of stimuli are available, the Affective Norms for English Text (ANET) (Bradley & Lang, 2007) and the Affective Norms for English Words (ANEW) (Bradley & Lang, 1999). An ambitious undertaking to correlate these datasets with linguistics knowledge is undertaken by Strapparava & Valitutti (Strapparava & Valitutti, 2004) who made a product called WordNet-Affect.

Using movies (films) to elicit emotions has been well established by Rottenberg et al., (Rottenberg, Ray, & Gross, 2007). Experimental validity and repeatability of film stimuli in different environments was demonstrated by Gross & Levenson (Gross & Levenson, 1995). Perhaps the most persuasive argument for the use of films is the depth and strength of emotions elicited, for example Rottenberg, & Gross (Rottenberg, Gross, Wilhelm, Najmi, & Gotlib, 2002) reported that approximately one third of female participants in their study openly wept after viewing a sad film.

Music and sound has been used by various researches such as (Liu et al., 2006) and (Wagner et al., 2005). While effective, it is prone to personal preferences influencing the elicited emotion.

Some physical devices may be used as emotional stimulus, for example popping balloons may be used to induce fear and a startle response (Kohn & Kalat, 2000). While balloons are a common theme, most physical devices are related to a task the user must perform which is expected to induce emotion.

Subjecting Humans to Tasks Known to Induce Emotions

Tasks that create emotions may be able to induce a high level of emotion, not generally created by the viewing of a slide, but will also induce physiological signals that directly relate to the task difficulty not the emotion (Veltman, 1996).

An example of a task that elicits emotions for use in PPR was presented by Scheirer et al., (Scheirer, Fernandez, Klein, & Picard, 2002) who enlisted 26 volunteers to participate in a competitive video game task. There was a cash reward offered for the person who could solve the game's puzzles the quickest. The system, and mouse, was rigged to behave as though they were faulty, thus inducing "frustration" as an emotion.

Having Humans Deliberately Express Emotions

An influential work by Picard, Picard et al., (2001) performed Physiological Pattern Recognition (PPR) of emotions using a single actor who deliberately invoked a set of emotions during experimental recording sessions conducted over several days. In this work Picard was able to achieve an 81.25% classification accuracy over 8 affective states. This work has been criticised by Kim, Bang and Kim (2004):

"Their feature vectors were extracted from a single subject under the condition of deliberate expression, and it is likely that they form clusters that can be discriminated with much less effort. The combination of dimensionality reduction and a simple classifier such as the quadratic classifier was never applicable for our multi-subject problem. Furthermore, it is generally considered that quadratic classifiers show poor performance when the number of training samples is not sufficient, owing to error in the estimated covariance matrix."

Other works that use deliberately expressed emotions involve facial expression research. As shown by Ekman and Rosenberg (2005) posed facial expressions are different from spontaneous expressions, in terms of appearance and timing. The focus of facial expression research is often seen as a computer vision problem, the goal being to develop algorithms useful in tracking emotive parts of the face, not achieving true emotion detection.

3.5.2. **Observing Emotion**

In this section we will introduce methods of inspecting the human emotional state. The methods can be broadly separated into external evaluation and self report.

The major advantage of external evaluation methods, such as the facial action coding system (Ekman & Friesen, 1978), is that they are unobtrusive as well as being language/culture independent. These methods use a panel of experts (or coders) who study a person's facial behaviour and other behavioural cues. They employed in a candid manor, via recorded footage or having a one way mirror, as was the case in the thesis by Axelrod (Axelrod, 2009). This type of process provides information regarding the presence of primary emotions (e.g. happiness/ anger). Studies generally report coders will agree on an assessment 60-80% of the time e.g. (Afzal & Robinson, 2009), (Sayette, Cohn, Wertz, Perrott, & Parrott, 2001) & (Ekman, Freisen & Ancoli, 1980).

In contrast to external evaluation, "self report" is a process by which a participant can describe their own (subjective) emotional experience. The subjective feeling (e.g. feeling happy or sad) is the conscious awareness of the basic, irreducible kind of affective state the person is experiencing (Titchener 1908).

A self report process requires participants to report their affective state with the use of a set of rating scales or verbal (or action) response protocols. According to (Desmet, 2003) the two major advantages of self reporting are that a survey can be assembled to represent any set of emotions, and can be used to measure mixed emotions. The main disadvantage is that they are difficult to apply between cultures.

A common self report device for collecting data in the dimensional emotion classification theory is the Self Assessment Manikin (SAM) (Bradley & Lang, 1994) (Bradley & Lang, 1994) The classical SAM, shown in Figure 33, uses three rating scales: “Arousal”, “Valence” and “Dominance” as per the three factors found in the semantic differential research by (Osgood, Suci, & Tannenbaum, 1957).

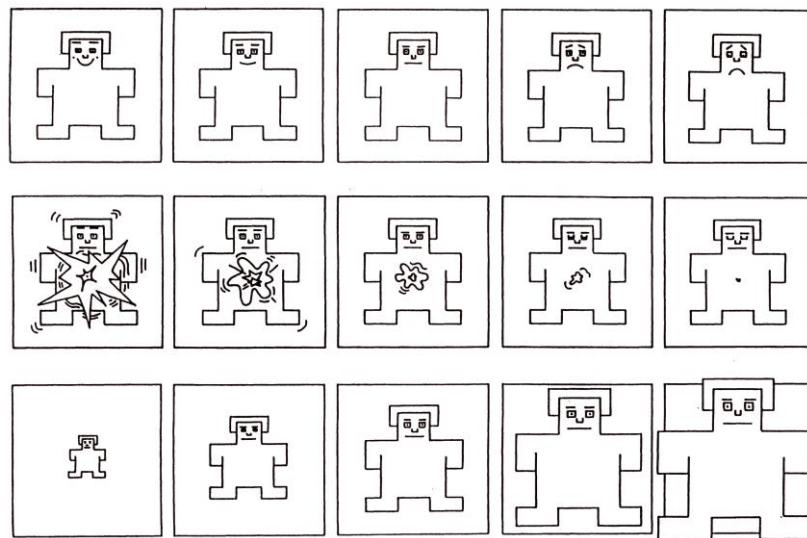

Figure 33: Self Assessment Manikin.

The top row is used to rate Valence, the second Arousal and the third Dominance.

The SAM offers several advantages as an emotion assessment device:

- It is cross cultural (Morris. J., Bradley. M. & Wei. L., 1994);
- It is completed in 3-15 seconds (Verbal techniques take much longer);
- It avoids individual subjective bias of words like “happy “ and “sad”;
- Children and adults can identify with the SAM character and understand how to fill out the questionnaire.(Lang, 1985), and the device produced valid results regardless of age (Bachs, da Silva, & Han, 2005);
- It is established and well understood. Huge volumes of data have been collected using this device (it’s a quasi-standard).

However the SAM does not provide information in the form of “The person was happy”, the information is instead in the form “The person’s emotional state contained a strong positive aspect”. To some researchers, this type of data was not desirable. To this end Desmet (Desmet, 2003) produced a self report system called the PrEmo. This device works by allowing the user to evaluate a set of 14 emotions that represent their

emotional state. Levels of a certain emotion can be indicated by animation of the character, see Figure 34 and Figure 35, and several emotions can be evaluated together to represent mixed emotional feelings.

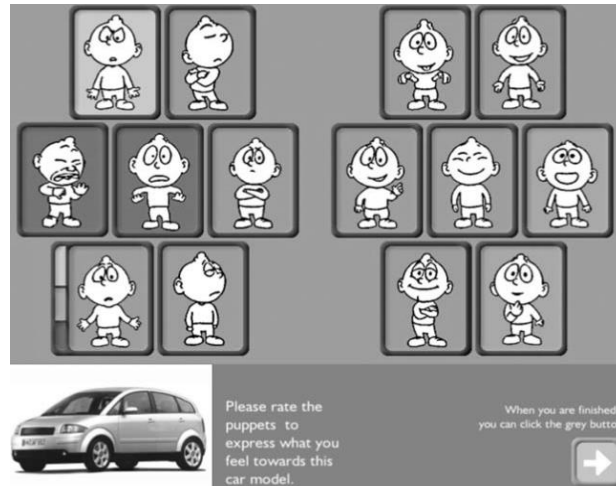

Figure 34: PrEmo Self Report Device by Desmet

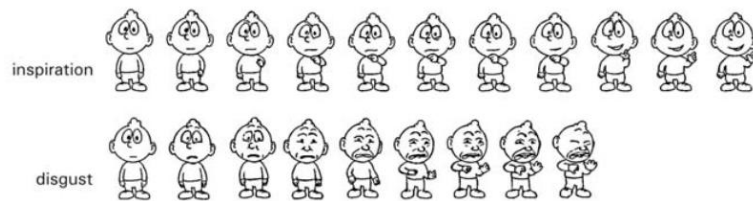

Figure 35: PrEmo Animations

The PrEmo system was shown to minimise cultural bias (due to verbalisation of emotion) and concentrated on positive and negative emotions elicited by product design, namely:

- Positive;
 - Desire;
 - Inspiration;
 - Admiration;
 - Fascination.
 - Pleasant surprise;
 - Amusement;
 - Satisfaction;
- Negative;
 - Indignation;
 - Disgust;
 - Dissatisfaction;
 - Boredom.
 - Contempt;
 - Unpleasant surprise;
 - Disappointment;

3.6 Human Emotion in Human Computer Interaction vs. Human Emotion in Research

In this section we present two differences between how we work with emotions in neurological and psychological contexts and how we envision emotions being applicable to Human Computer Interfaces (HCI). These two differences being:

- The varied importance of Dominance as an emotional factor
- The presence of weekly induced emotions.

As covered earlier Osgood, Suci, & Tanenbaum (1957) identified Arousal, Valence and Dominance as being the three factors of a dimensional view of emotion. This view is often adapted to suit particular theories or needs. Most often the Dominance Axis is discarded when working with emotions e.g. (Surakka & Anttonen, 2005), (Feldman, 1995), (Lewis et al., 2007) & (Kulic & Croft, 2007).

Removing Dominance is often used in emotional theories e.g. the Circumplex Model of Emotions (Russell, 1980). It is also done to improve the results of classification experiments as the stronger factors Arousal and Valence often provide the best correlations with data.

Discarding the Dominance axis generally improves classification accuracy; however Dominance is an emotional dimension which is significant to HCI. In fact Dryer (1998) in creating a model for working with emotion in HCI only used the Valence and Dominance factors. In Figure 36 we present how a user's competency in using a piece of software is likely to map to the dominance component of emotions they experience while using the software.

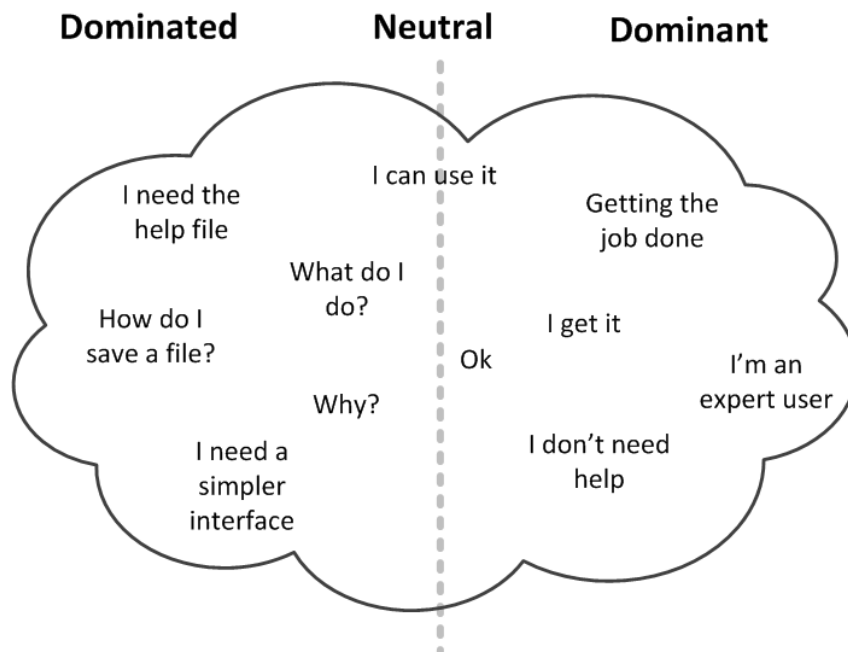

Figure 36: User thoughts in HCI mapped onto emotional dominance.

Another consideration of emotions in HCI is that computers generally don't strongly induce emotions, except in the case of user frustration. That is the emotion felt when we use computers is often less present than the emotion felt in real life situations. For example, in playing driving simulator (Lisetti & Nasoz, 2005), (Nass, et al., 2005) the user will generally have a reduced emotional and stress levels compared to driving a real car (Katsis, et al., 2008) (Healey & Picard, 2000).

A common trend in attempting to get research results in emotion recognition to translate to practical application, is to use a naturalistic environment for inducing the emotions to be studied (R. Mandryk, 2005). This often involves the user moving around and physically performing a task, e.g. driving, and thus often strongly induces emotions. However for many computer users the calm seated position used in our research is not dissimilar to the typical home/office use of a computer.

3.7 Summary of Physiological Pattern Recognition Research and Experiments

An early effort in using PPR to detect emotion was conducted by (Picard, Vyzas, & Healey, 2001). In this study a single participant repeated a 25 minute experiment for

30 days. The participant sat each morning in a quiet workspace and used imagery techniques and a sentograph (Clynes, 1978), as shown in Figure 37, to produce eight different emotions (no emotion, anger, hate, grief, platonic love, romantic love, joy and reverence). Recordings of EMG, BVP, GSR and respiration were sampled at 20Hz for the duration of each session. After compensation for a “day dependence” effect, Picard was able to detect the correct emotion at a rate of 81% using the Fischer Projection¹ and Linear Discriminant Analysis (LDA).



Figure 37: The Sentograph (Clynes, 1978). A two-dimensional touch transducer for biocybernetic measurements of finger pressure.

In a more traditional experiment design that involved multiple participants, Nasoz et al., (Nasoz, Alvarez, Lisetti, & Finkelstien, 2003) used a series of short films to elicit the emotions: sadness, anger fear, surprise, frustration and amusement in 24 participants. They recorded heart rate, skin temperature and GSR at what we believe to be 32Hz, given the capability of the encoding unit they used. They train several classification systems including k-Nearest Neighbour Algorithm (KNN), Discriminant Function Analysis (DFA) (Nicol, 1999) and ANN's trained using the Marquardt Back-propagation algorithm (MBG) (Hagan & Menhaj, 1994). The ANN was the most successful technique, achieving an accuracy of 83% as shown in the confusion matrices presented in Figure 38.

¹ A method for projecting a 3D structure onto a 2D Plane

Emotion Recognition Results with MBG Algorithm

Recognized Emotion	Elicited Emotion					
	Sadness	Anger	Surprise	Fear	Frustration	Amusement
Sadness	92%	0%	0%	0%	4%	0%
Anger	8%	88%	9%	5%	9%	4%
Surprise	0%	0%	70%	8%	0%	4%
Fear	0%	8%	4%	87%	0%	0%
Frustration	0%	4%	13%	0%	82%	9%
Amusement	0%	0%	4%	0%	4%	83%

Emotion Recognition Results with DFA

Recognized Emotion	Elicited Emotion					
	Sadness	Anger	Surprise	Fear	Frustration	Amusement
Sadness	78%	8%	0%	4%	9%	0%
Anger	4%	72%	5%	0%	0%	4%
Surprise	4%	4%	71%	9%	5%	4%
Fear	7%	8%	14%	83%	13%	9%
Frustration	0%	4%	10%	4%	68%	17%
Amusement	7%	4%	0%	0%	5%	74%

Emotion Recognition Results with KNN Algorithm

Recognized Emotion	Elicited Emotion					
	Sadness	Anger	Surprise	Fear	Frustration	Amusement
Sadness	67%	8%	0%	0%	0%	0%
Anger	4%	67%	0%	0%	4%	0%
Surprise	7%	4%	67%	13%	4%	4%
Fear	7%	8%	15%	87%	20%	13%
Frustration	7%	13%	9%	0%	72%	13%
Amusement	7%	0%	9%	0%	0%	70%

Figure 38: Confusion matrices for training performed Nasoz et al., (Nasoz et al., 2003). MBG Marquardt back-propagation algorithm trained ANN; KNN k-Nearest Neighbour Algorithm; DFA Discriminant Function Analysis.

Haag et al., (Haag, Goronzy, Schaich, & Williams, 2004) presented a work that did not use discrete emotion categories in their classification task. Instead, ANN's were tasked with predicting the reported Arousal and Valence levels. The emotions of participants were elicited using the International Affective Picture System (IAPS) (Lang, Bradley, & Cuthbert, 1997) slide set, with participants being exposed to each

slide for a period of 15 seconds. The slides in this work were presented in an order which allowed for a progressive increase in Arousal level, so as to minimise the disturbing effect of any one slide on subsequent slides. This study also ensured that the high Arousal negative Valence (gore) slides were shown last so as to not form a lasting effect of horror that may affect other readings.

Extracting 13 features from EMG, GSR, Skin temperature, BVP, ECG and Respiration signals, Haag constructed two ANN's for Arousal and Valence detection respectively. Each ANN had an input vector with 13 nodes, one hidden layer with 10 neurons and a single output node. Allowing for a 20% bandwidth in classifying a prediction as correct, this study was able to correctly predict the emotional state around 90% of the time. The Arousal ANN was significantly better in performance than the Valence ANN. These results are extremely good, however when a 10% bandwidth was used for evaluating performance the results were more modest, as shown in Table 6.

Table 6: Training Results for Haag et al., (Haag, Goronzy, Schaich, & Williams, 2004). Columns are for ANNs trained to predict Arousal and Valence levels at 10% and 20% bandwidths.

Bandwidth	Arousal		Valence	
	<i>10%</i>	<i>20%</i>	<i>10%</i>	<i>20%</i>
Correct	89.73%	96.58%	63.76%	89.93%
Wrong	10.27%	3.42%	36.24%	10.07%

A work that stands out in terms of the number of participants is Kim et al., (Kim, Bang, & Kim, 2004) who used 175 participants (normally around 30 is all that most researchers manage to achieve in practice). The participants in this case were all children aged from five to eight years old. They used a Support Vector Machine (SVM) to classify recordings taken from ECG, GSR and Skin temperature into three and four different emotional states; anger, stress, sadness and surprise (the extra). Using a later group of their participants (50 subjects) they achieved a 78.43% and 61.76% classification accuracy respectively using SVM's. While their results were very good, the use of only three or four emotional states made the error rate a lot lower as the chance probability was 33.3% and 25% respectively.

What was interesting in the works of Kim et al. was the emotion elicitation strategies that were used:

- Sadness;
 - Story that evokes sympathy of subject told in appealing tone/crying voice;
 - Sad background music;
 - Toy with gloomy-looking appearance;
 - Blue illumination.
- Anger;
 - Story that deceives subjects told in sarcastic voice;
 - Situation of feeling mortified;
 - Toy with unpleasant appearance;
 - Red illumination.
- Stress;
 - Subject pressed to complete impossible mission in short time;
 - Subject compared unfavourably with other subjects;
 - Disordered environment, making it hard to concentrate on mission;
 - Grim looking doll;
 - Flickering illumination.
- Surprise;
 - Sudden increase in volume of background music;
 - Intermittent sound of buzzer and breaking glass.

One can easily imagine the intensity and uniformity in which such activities would create emotion in children aged five to eight.

A very significant result was achieved by Lisetti & Nasoz (Lisetti & Nasoz, 2004) who elicited the emotions sadness, anger, fear, surprise, frustration and amusement using movie clips and mathematical problems. They measured GSR, heart rate and temperature of 29 participants. Using k Nearest Neighbour (KNN), Discriminant Function Analysis (DFA) and Artificial Neural Networks trained via Marquardt Back Propagation (MBP) classifiers they achieved accuracy rates of 72.3%, 75.0% and 84.1% respectively.

Extending these works into the domain of participant independent (heterogeneous) classification, Leon and Clarke (Leon, Clarke, Callaghan, & Sepulveda, 2007) were able to create a classification system using an Auto-Associative Neural Network (AANN) that worked across eight different participants. They were able to classify three emotional states at a 71% accuracy ratio.

Research into PPR for emotion detection is still an active research area. Many studies have been completed. There have been some results in terms of heterogeneous classification (Leon et al., 2007), but those results were for a small group and only visited three emotional states.

In general, the research is focused on homogeneous (person specific) classification tasks. Many works suffer from a weakness that would impede their adoption into affective technologies; such as using only a limited set of emotions (four or less), not being trialled on a large ($n > 20$) group of participants, or not producing a good classification rate ($> 80\%$). We have compiled a summary of notable works in Figure 39 to demonstrate this fact.

Ref	P	# Emotional States	Sample Hz	Signals	# Features	Reduction Algorithm	Classifier	Classification Accuracy
(Sinha, 1996)	27	2 (fear vs. anger)	10Hz	EMG	18	none	LDA	86%
(Picard, Vyzas, & Healey, 2001)	1	8	20Hz	EMG, BVP, GSR RS	40	SFS, Fisher	LDA	81%
(Scheirer, Fernandez, Klein, & Picard, 2002)	24	2 (detect frustration)	20Hz	EMG, BVP, GSR	5	Viterbi	HMM	64%
(Nasoz, ALVAREZ, Lisetti, & Finkelstien, 2003)	24	6	32Hz*	HR, ST, GSR	3	none	kNN, DFA, MBP	69%
(Takahashi, 2004)	12	6	3,000Hz*	BVP, GSR, EEG	18	none	SVM	42%
(Haag, Goronzy, Schaich, & Williams, 2004)	1?	valence/arousal	256Hz* (ECG, EMG) 32Hz* (otherwise)	EMG, GSR, ST, BVP, ECG, RS	13	none	MLP	90%
(Kim, Bang, & Kim, 2004)	175	3	256Hz	EKG, GSR, ST	8	none	SVM	78%
(Lisetti & Nasoz, 2004)	29	6	32Hz*	HR, ST, GSR	12	none	kNN, DFA, MBP	84%
(Wagner & Andre, 2005)	1	4	?	GSR, EMG, RS, ECG	32	none	kNN, LDA, MLP	92%
(Yoo, Lee, Park, & Kim, 2005)	6	4	?	HR, GSR	5	none	MLP	80%
(J. A. Healey & Picard, 2005)	9	3 (levels of stress)	496Hz (ECG), 31Hz (GSR, RS), 15.5Hz (EMG)	ECG, EMG, GSR, RS	22	Fisher	LDA	97%
(Rani & Liu, 2006)	15	3	1,000Hz* (ECG) / 500Hz*	ECG, BI, EMG, GSR, ST, BVP, HS	46		kNN, SVM, RT, BN	86%
(Zhai & Barreto, 2008)	32	2 (levels of stress)	?	GSR, BVP, ST, PD	11		SVM	90%
(Leon & Clarke, 2007)	8	3 (heterogeneous)	?	GSR, BVP, HR	5	DBI	AANN	71%
(Liu & Conn, 2008)	6	3	?	GSR, EMG, RS, ?	35		SVM	83%
(Katsis, Katertsidis, Ganiatsas, Fotiadis, & Member, 2008)	10	4	1,000Hz(EMG), 500Hz(EGC), 50Hz	EMG, ECG, RS, EDA	15		SVM, ANFIS	79%
(Yannakakis & Hallam, 2008)	72	2 (detect fun)	256Hz	HR, BVP, SC	20	ANOVA	SVM, MLP	70%
(J. Kim & Ande, 2008)	3	4	256Hz(EGC), 32Hz otherwise	ECG, EMG, RS, GSR	110	SBS	LDA, EMDC	70/95%
(Gouizi, Bereksi Reguig, & Maaoui, 2011)	4	6	2048Hz*(EMG), 256Hz* otherwise	GSR, BVP, RS EMG, ST, HR	18	none	SVM	83%

*Sample rate not stated in paper, frequency provided is the maximum capacity stated on a product brochure concerning the hardware mentioned.

Figure 39: Summary of PPR Research into Emotion Classification. EMG Electromyography; BVP Blood Volume Pulse; GSR Galvanic Skin Response; RS Respiration; ST Skin Temperature; HR Heart Rate; ECG Electrocardiogram; BI bio-impedance; HS heart sounds; PD Pupil Diameter; EDA blood-glucose levels; SFS Sequential Backward Selection; Fisher Fisher Projection; LDA Linear Discriminant Analysis; HMM Hidden Markov Model; kNN k Nearest Neighbour; MLP Multilayer Perceptron; DBI Davies-Bouldin Index; ANOVA Analysis of Variance; BN Bayesian Network; RT Regression Tree; AANN Auto-Associative Neural Network; ANN artificial neural network; ANFIS Adaptive Neuro-Fuzzy Inference System; EMDC Emotion-specific Multilevel Dichotomous Classification; SVM Support Vector Machine; DFA Discriminant Function Analysis; MBP Marquardt Back Propagation.

3.8 Conclusion

In this literature review, we covered a range of topics that relate to the task of PPR for the purpose of classifying human emotion. We reviewed the different techniques used to recognise emotions in humans and established that PPR is an important technique.

We also established that there are still many challenges to be solved in the field of PPR (Picard, 2000) & (van den Broek et al., 2009) and presented some relevant literature on emotional theories. We then reviewed the major signals used in PPR research and how they relate to emotions, cognitive processes and human physiology.

An examination of the literature on eliciting human emotion in participants in terms of effectiveness was given with a focus on the International Affective Picture System (IAPS) (Lang, Bradley, & Cuthbert, 1997).

Lastly we concluded the chapter with a review of literature concerning works similar to our own, discussing their results and examining where useful contributions could be made.

The next chapter is, in part, a continuation of the literature review. It visits the human face and how it shows emotion. Then chapter 5 investigates the EMG signals that can be obtained from the face. This work regarding the face was given its own chapters because the face plays such a prominent role in the display of emotion.

4.0 The Human Face and its Coupling with the Emotional State

“God hath given you one face, and you make yourselves another.”

-William Shakespeare (1564 - 1616)

Many of the physiological signals covered so far have strong correlations with the activation component of emotional dimension models. To help perform better classification, we wish to find a physiological signal that correlates with the Valence component of emotional experience. To this end we believe facial electromyography to be a good solution, as the face is often used in expressing positive and negative emotions.

In this chapter we aim to identify facial muscle that has movements which correlate with emotional Valence and are affected as little as possible by other cognitive or physiological processes. It has a background, literature review and some level of investigation which runs tangential to our main research questions. In this chapter we explore the roles, emotional function and electromyography of the facial muscles, with the goal of determining which facial muscle is the best candidate for electromyographical investigation of the emotional state.

To determine this candidate we will examine various muscles and where applicable use current literature or our own work to answer:

- 1) What are the muscles' roles in displaying emotion? Is it significant?
- 2) Is the muscle prone to conscious control (social display rules) which would mask its emotional actions?
- 3) Does the muscle have a role in displaying the Valence component of emotional states?

In the cases that these background questions are positive, we performed some preliminary EMG work using deliberately posed facial expressions to determine if the muscle is a candidate for EMG investigation:

- Are there clear electromyographic features which indicate its actions?
- Is there a high noise level or other nearby muscle movements which interfere with the signal being recorded?

4.1 Background of Facial Expression in Relation to Emotions

Scientific investigations of facial expressions and their link to emotions have produced various results that are of importance to Physiological Pattern Recognition.

There are three rudimentary questions concerning facial expressions and their link to emotions that influence the practicality of finding correlations between facial readings and emotional state:

- Is there any relationship at all?
- Are facial expressions innate or are they a learned skill?
- Are facial expressions universal or bound to an individual or a culture?

A pioneering work in establishing the link between facial expressions and emotions was conducted by famed French neurologist Duchenne (Duchenne, 1876) in his work “Mecanisme de la Physionomie Humaine” where he systematically controlled muscles electrically to study facial expressions. The “Duchenne Smile” (a genuine smile which is expressed with the eye muscles as well) was named in his honour. Some examples of his work are shown in Figure 40.

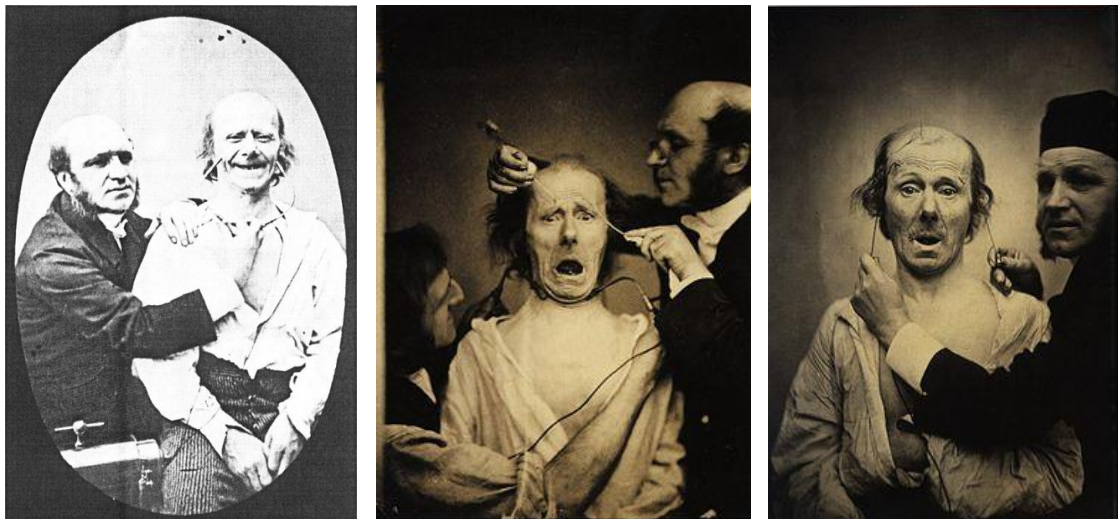

Figure 40: Photographs of Duchenne Experiments (Duchenne, 1876)

In more recent studies conducted by Ekman, Friesen & Ellsworth (1972, 1982), a strong relationship between emotional state and facial expression was found. Ekman

et al. established that observers could agree on the classification of posed and spontaneous facial expressions into discrete categories or emotional dimensions. There are still no strong results to suggest that facial expression can provide distinctions between certain fine emotional states such as fear and anger. There is no evidence to suggest that facial expressions can provide information regarding intensity of any specific emotion.

It is important to know if the facial expressions of humans are an innate biological response or the result of learned behaviours. This distinction may help us when examining correlations because we are still unsure whether emotions are bound to our biological or neurological states. In studies performed on blind infants and children, Charlesworth & Kreutzer (1973) found common facial reactions to positive and negative stimuli. Paul Ekman (Ekman, 1972) after studying seven cultures provides compelling evidence to suggest that many facial expressions are innate responses and not learned. Also supporting this theory, Steiner (1973) shows a patterned facial response in anencephalic* neonates to sweet and bitter tastes.

The presence of universal facial expressions across multiple cultures was shown by Izard (1971) and Ekman, Sorenson and Friesen (1969). Ekman later went on to introduce the concept of “display rules” (Ekman, 1972). Display rules are an informal, non-verbal, culture specific etiquette governing socially expected ways to display emotion. For instance in many western societies it is normally undesirable for an adult male to cry in public. Other examples include the requirement that people display grief when attending a funeral or humbleness when accepting an award. To this end, if facial expressions are to be used in emotion recognition, then some effort must be made to overcome facial expressions made to deliberately mask true feelings or to comply with social display rules. Ekman, Friesen and Wallace (1998) describe methods to detect genuine smiles as opposed to masking smiles by increased activity in the muscles surrounding the eyes, causing the formation of “crows’ feet”.

* A disorder involving partial or total absence of the brain (failure of the brainstem to develop)

4.1.1. **Emotional vs. Conscious Facial Muscle Activation**

A large body of neurological evidence is arising to indicate that the emotional functions in the brain have their own direct connection to the motor system. This effect is most pronounced (and generally accepted) in facial expression (Ekman, 2006). In an exemplar case, Picard (1997, page 42), describes a patient paralysed on one side of their body who is unable to form a smile when asked; as only one side of the mouth will move. However, when the patient hears a joke a full smile is formed. This shows that the separate subconscious link is capable of controlling facial muscles even when regular motor control pathways are destroyed.

4.1.2. **Facial Display Rules and Micro Expressions**

The face is a primary mechanism for communication of emotions both through its expression and through other people interoperating its expression. However the nature of human society makes transparent communication of emotion undesirable; often a real emotion is hidden and an "apparent emotion" is displayed in order to conform with social display rules (Hochschild, 1979) or achieve a necessary deception (Ekman, 2003). An example of conforming to social display rules is shown in Figure 41, which shows a person observing a large ship turned on its side due to an unloading accident. The person initially finds the scene humorous but then displays a sad face to show appropriate concern for the workers on board.

Josephs (1994) shows that children in the age group four to six are developing an understanding of the difference between real and apparent emotions. Josephs also showed in an experiment that children, who were too young to properly grasp real and apparent emotions, when given an unattractive gift will hide their disappointment when in a social situation.

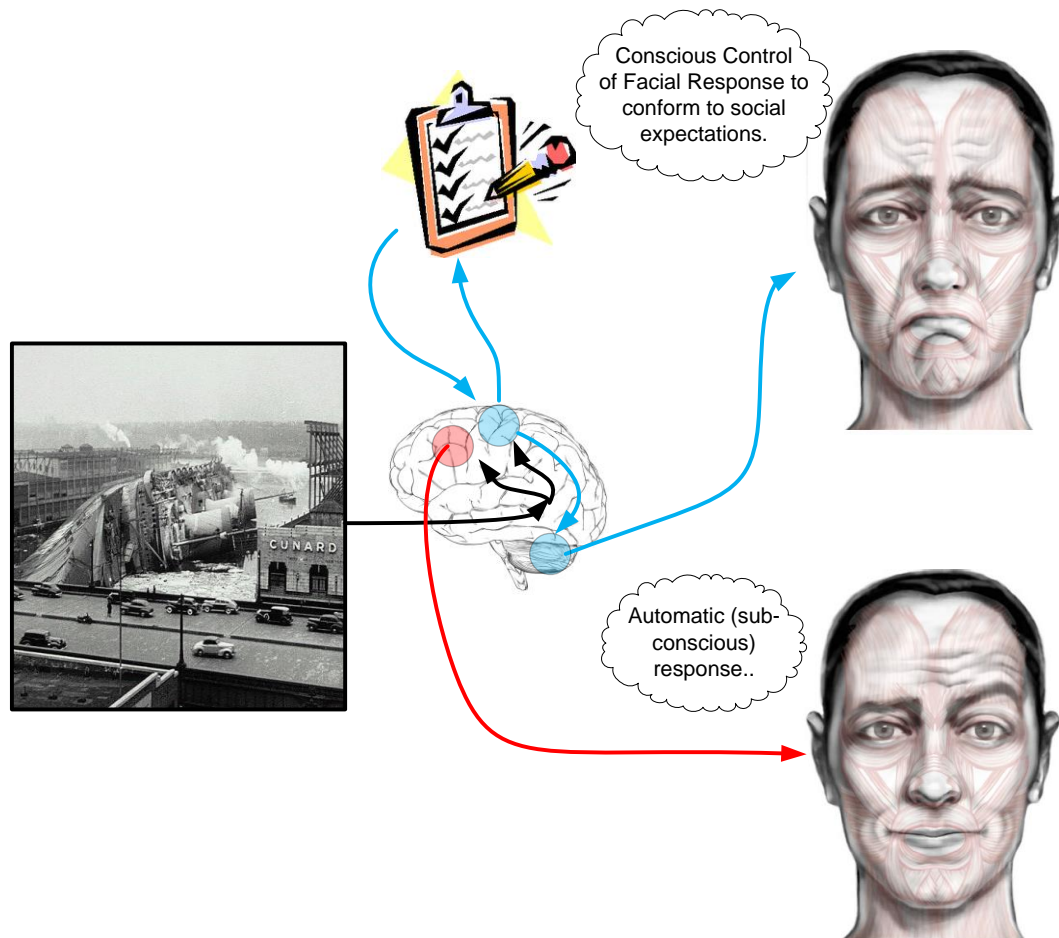

Figure 41: Modulation of facial expression to produce an apparent emotion in line with social display rules.

This masking of real emotions in the face causes difficulty in examining the face to determine the state of a person's real emotion. There are four main methods discussed in literature to discover the real emotion present in a facial expression, or signals acquired from a facial expression:

1. Create a private non-social environment where participants won't feel the need to mask their emotions;
2. Examine facial muscles which people are typically less able, or unlikely to consciously control;
3. Find differences in the way muscles are activated or moved when under conscious control;
4. Exploit the nature of strong emotional responses creating brief involuntary facial changes (Haggard & Isaacs, 1966), which can be as brief as 40 milliseconds (Ekman, 2003; Ekman & Friesen, 1978) and are often referred to as micro[momentary] expressions.

Micro expressions are evident in high stakes situations and extensively studied as a technique to be employed by human readers; however there remains no significant work to detect micro expressions via automated EMG or signal processing systems (Bettadapura, 2009).

For the purposes of this work the action of display rules on facial EMG is minimised via creating a non-social environment and investigating facial muscles which are less prone to conscious control.

4.1.3. **Facial Feedback Theory and its Implications for Emotion Research**

A relationship between facial expression and emotional state, called the facial feedback hypothesis, was posited by early thinkers including Charles Darwin (Darwin, 1998) who wrote -

"The free expression by outward signs of an emotion intensifies it. On the other hand, the repression, as far as this is possible, of all outward signs softens our emotions... Even the simulation of an emotion tends to arouse it in our minds"

The essential premise behind facial feedback is that facial actions are not purely efferent (from the brain out - muscle control) but also possessed afferent (from the body to the brain - sensory mechanisms). This idea is shown in Figure 42.

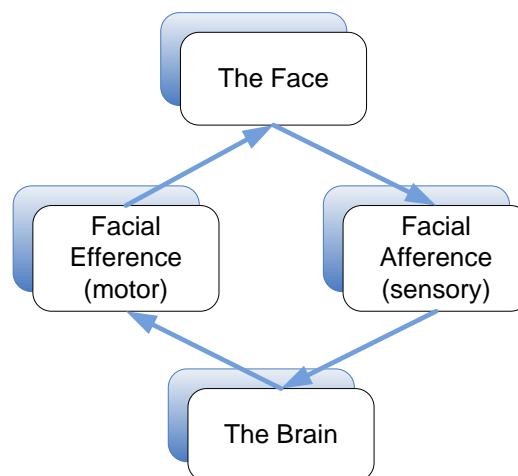

Figure 42: Basic premise of facial feedback

The theory was modernised by an often cited (and publicised) study undertaken by Strack, Martin and Stepper (1988) who asked participants to hold a pen in their mouth using either their teeth or their lips, as shown in Figure 43. A control group did the experiment using their non-dominant hand to hold the pen.



Figure 43: Lips, teeth and alternate teeth conditions for holding a pen.

The study utilised a cover story "we are determining the difficulty for people without the use of their hands or arms to accomplish certain tasks" and presented a bogus survey. The final item of the bogus survey was the real question being studied; it asked the participant to rate the funniness of a set of four Garry Larson cartoons. The results from the study, shown in Table 7, show that the teeth placement consistently improves the perceived humour of the stimulus.

Table 7: Results of Strack et al., (Strack et al., 1988). 0=not funny, 9=maximum funny

Cartoon	Lip	Hand	Teeth
First	3.90	5.13	5.09
Second	4.00	4.10	4.19
Third	4.47	4.67	5.78
Fourth	4.90	5.17	5.50
Mean	4.32	4.77	5.14

Many facial feedback studies have proven difficult to complete and prone to flaws in the experimental methodology. Early views of the facial feedback theory were sceptical and summary papers such as the meta-analysis by Matsomoto (1987) found a very modest effect may be attributable to facial feedback. A more recent summary

paper, presented by McIntosh (1996), which reviewed more recent developments, has concluded there is evidence to support the following theories:

- Facial actions are sensitive to social context;
- Facial actions correspond to the affective dimension of emotions;
- Matching Facial Actions with specific emotions is unlikely;
- Facial actions modulate ongoing emotions, and initiate them.

The process of facial feedback is often viewed as a distinct theory of the emotional mechanisms, as shown in Figure 44.

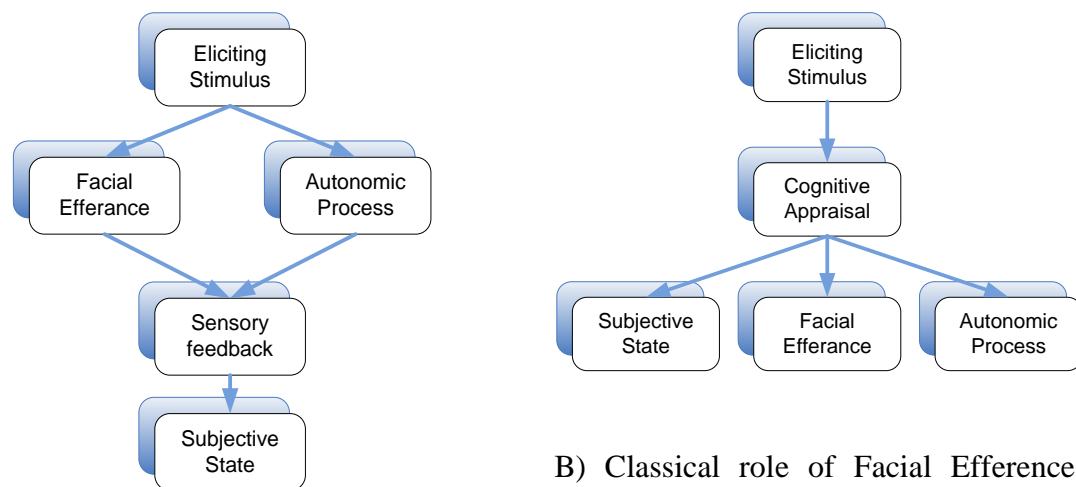

A) The role of facial feedback in facial feedback based theories of emotion.

B) Classical role of Facial Efference in emotional theories based on Cognitive Appraisal (eg James-Lang).

Figure 44: A) Wider view of facial feedback in relation to emotion as compared to, B) classical thoughts on facial expression.

An insightful theory called “The Vascular Theory” concerning facial feedback was proposed by Waynbaum (1907) at the beginning of the 20th century. This theory proposes that the facial musculature of mammals controls the temperature of the base of the brain (specifically the hypothalamus) by regulating blood flow. The basis of the theory states that elevated temperature in parts of the hypothalamus can produce aggressive behaviour and depressed temperatures can produce relaxation. This may have ties to the emotional phrases “hot headed” and “keeping his cool”.

Waynbaum's theory had some flaws (medical science at the time did not properly understand blood flow to the face) and given the "enthusiast" nature of science at the

time, his theory fell into obscurity. The theory was reclaimed in 1985 when Zajonc (1985) modernised the ideas and presented a strong rationale for the theory and then continued investigation into its implications (Zajonc, Murphy, & Inglehart, 1989).

Zajonc (1985) stated:

"The entire emotional process can therefore be conceptualised as being triggered by an internal sensory or cognitive event that leads to peripheral muscular, glandular, or vascular action that in turn results in a change of the subjective hedonic tone."

This argument would indicate that the facial movements universally associated with emotions are no different than sneezing or yawning; that is they are the result of biological processes. An overview of the vascular theory is shown in Figure 45.

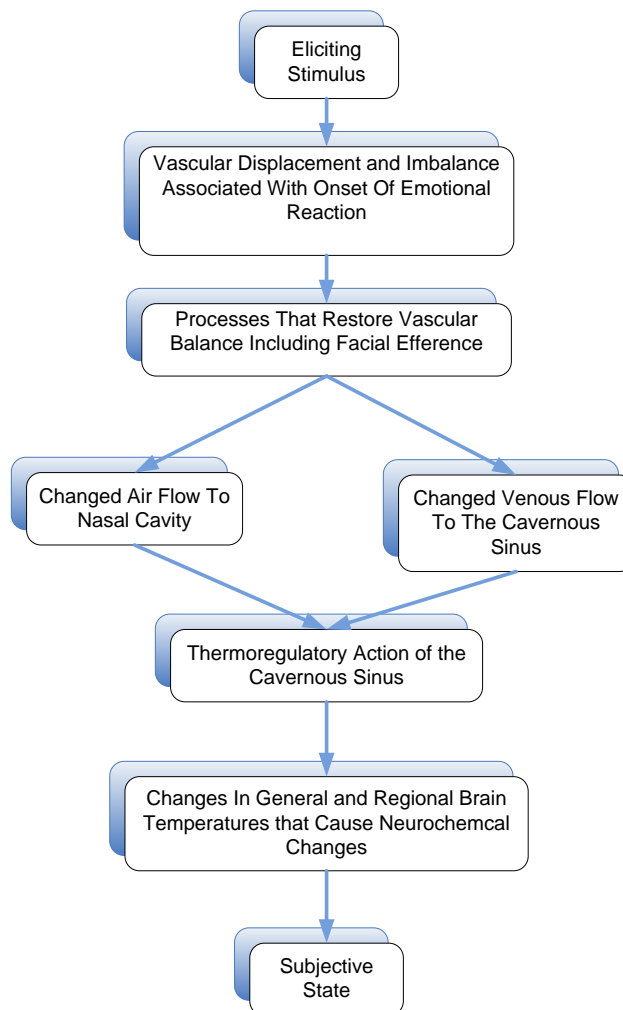

Figure 45: the vascular theory of emotion

If any of the facial feedback theories of emotion can be proven it would open up a significant research direction for Physiological Pattern Recognition. It would become possible to directly manipulate emotional states by asking participants to pull a funny face, or perhaps modulate emotional experience by using muscular feedback blocking devices such as Botox. However, if the vascular theory of emotion could be proven it may become possible to manipulate emotion via manipulation of the nasal cavity.

A new bank of evidence to support the facial feedback hypothesis is being realised through experiments using botulinum toxin (Botox) to inhibit facial afference. Many works have shown various effects in regards to self reported response to emotional stimuli caused by injecting Botox into particular facial muscles. Notably Davis, Senghas, Brandt and Ochsner (2010) conducted work injecting Botox and Restylane (as a control) into groups of women and examining the effects on the participant's response to emotional stimuli. The results showed a decrease in the strength of emotional experience (see Figure 46) and concluded that facial feedback has an influence on emotional experience in some circumstances. Similar notable works (Havas, Glenberg, Gutowski, Lucarelli, & Davidson, 2009) & (Hennenlotter et al., 2009) have also demonstrated similar results in support of the facial feedback hypothesis.

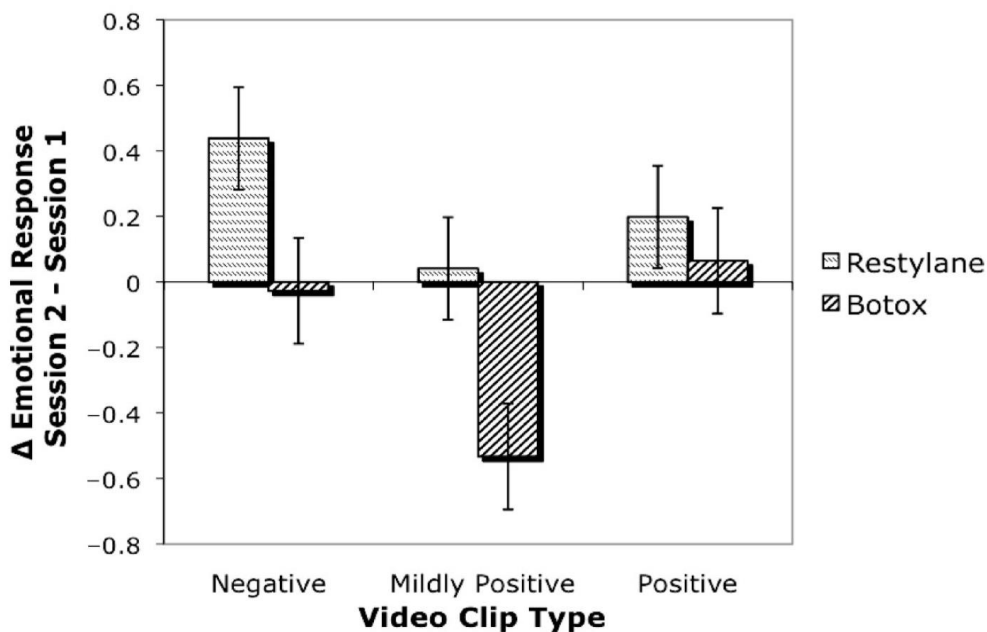

Figure 46: Results obtained by Davis et. al., showing the effects of Botox and Restylane (the placebo) in processing emotional stimuli.

The author is unaware of any studies that directly manipulate the nasal cavity to regulate emotion, but in a review of related research, Zajonc presented the following anecdotal evidence supporting the emotional effect of nasal breathing:

- Packing the human nose with gauze tampon (to prevent ambient air reaching the nasal mucosa) can result in a violent emotional reaction;
- Patients who breathe through tubes inserted directly into the trachea often experience severe emotional reactions (Bendixen, Egbert, Hedley-Whyte, Laver, & H., 1965);
- When the nose is obstructed, to the point where it is easier to breathe through the mouth, people will continue with their usual proportional preference to nasal breathing. (Vig, 1985)

As the Facial Feedback Theory is still under development, and the exact nature of any of its possible effects are still being studied, we will not be using facial feedback to stimulate emotions. However we consider it vital to design our experiment on the grounds of Facial Feedback being a valid theory. As such, all facial sensor placements are designed not to pull the facial muscles, so as not to add another (uncontrolled) source of emotional manipulation.

4.1.4. **Our Guidelines for Experimental Apparatus in Affective Facial Studies**

The preceding sections have reviewed a set of conflicting theories linking facial action and emotion. As the question of which (if any) theory is correct remains unanswered, it is our goal to construct a framework for an experiment which would not be invalidated if a particular emotional theory was proven. The goal of our framework is to propose methodologies consistent with the unified areas of various facial/emotional theories (see Figure 47).

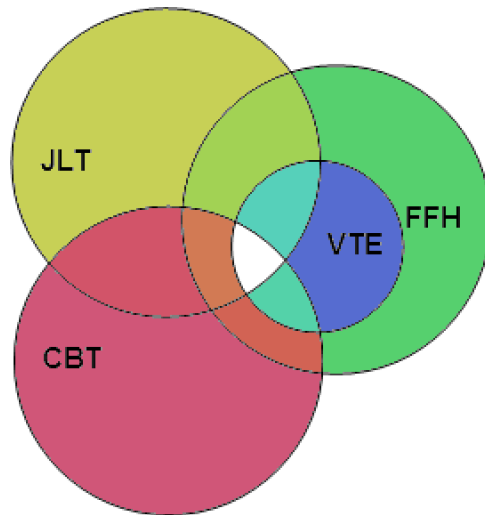

Key

JLT	James Lang Theory
FFH	Facial Feedback Hypothesis
VTE	Vascular Theory of Emotions
CBT	Cannon-Bard Theory

Figure 47: Venn diagram of selected emotional theories

Proposed Guidelines

- a) Facial measurement apparatus should not impinge on the action of the face, or be made to have minimal such effect. (see Facial Feedback Hypothesis):
 - a. Electrodes should be small and light;
 - b. Size of electrode adhesive pads should be minimal;
 - c. Electrode wires should not hang loosely and thus pull on the face;
 - d. The net force exerted by electrodes should be measured and recorded.
- b) Human observers should not be present unless the experimental methodology explicitly requires such presence, because:
 - a. Human facial actions are socially augmented. An observer will place pressure on the participant to outwardly display culturally acceptable responses;
 - b. Some theories state that humans transfer emotions through facial efference and empathetic processes. If the participant sees another face, that face becomes an uncontrolled emotional stimulus.
- c) Wall charts and medical manikins should be avoided in the experimental area, especially if any charts, posters, or manikins display a face or facial expression.

4.2 Facial EMG as a Method of Studying Emotional State

There is sufficient published work to establish a link between facial EMG and self reported emotional state. Notable publications showing this relationship include Bradley, Codispoti, Cuthbert and Lang (2001) and the related work by Bradley, Codispoti, Sabatinelli and Lang (2001).

It has long been established that facial expressions are a primary mechanism for communicating emotions between people. Thus the bulk of EMG related work in emotion related field tends to utilise the facial muscles, though works also examine muscles related to posture.

Many muscles in the face correlate to different emotions and expressions. All of these muscles can be controlled consciously and unconsciously. In this section we visit the literature for the important muscles in facial expression and detail the expressions and where possible level of conscious / unconscious control commonly used.

4.3 Physiological Signals (EMG) of the Jaw

The mouth is a very expressive part of the human face. There are ten muscles which move the mouth which can be observed using EMG:

- Orbicularis Oris;
- Levator Anguli Oris (Caninus);
- Levator Labii Superioris (aka Quadratus Labii Superioris);
- Zygomaticus Minor;
- Zygomaticus Major;
- Buccinator;
- Quadratus Labii Inferioris;
- Depressor Anguli Oris;
- Mentalis;
- Risorius;
- Platysma.

In this section we will review the function and related literature on the emotional responses of these muscles. Note: the Masticator was not reviewed as it is functionally used for chewing and not involved in displaying emotion.

4.3.1. **Orbicularis Oris**

The Orbicularis Oris muscle is the sphincter muscle around the mouth as shown in Figure 3.

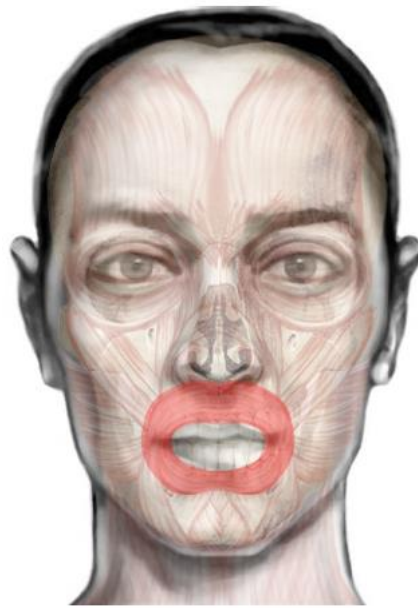

Figure 48: Location of the Orbicularis Oris.

In the composition of facial expression it has two actions (Faigin, 2008) , (Boulogne, 1990) & (Standring & Gray, 2008):

- a) By contracting the peripheral portion of the muscle it compresses the lips forcing them outward;
- b) By contracting the internal fascicules it projects the lips inwards towards the teeth.

The two actions of the Orbicularis Oris are pictured in Table 2.

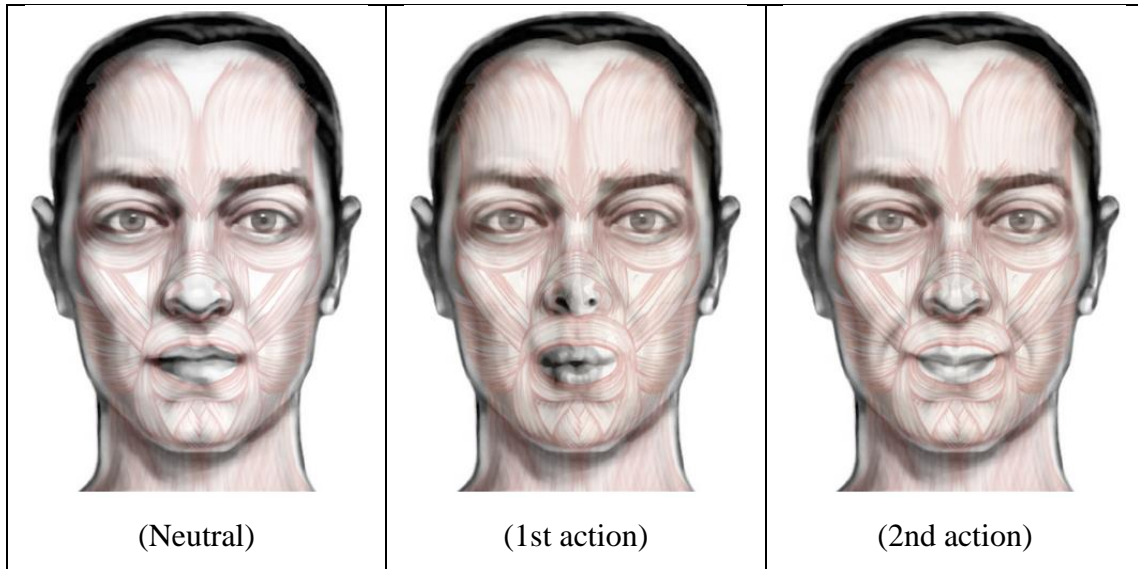

Figure 49: Actions of the Orbicularis Oris

The Orbicularis Oris is used to perform the following actions (Faigin, 2008) , (Boulogne, 1990):

- Kiss;
- Blow;
- Whistle;
- Suck;
- Forming "tooth-lip" consonants.

The activity in the orbicularis oris has been linked to the degree of mental effort involved in a task being under taken (A. Van Boxtel & Jessurun, 1993).

4.3.2. Levator Anguli Oris (Caninus)

The Caninus muscle is a facial muscle of the mouth as shown in Figure 4.

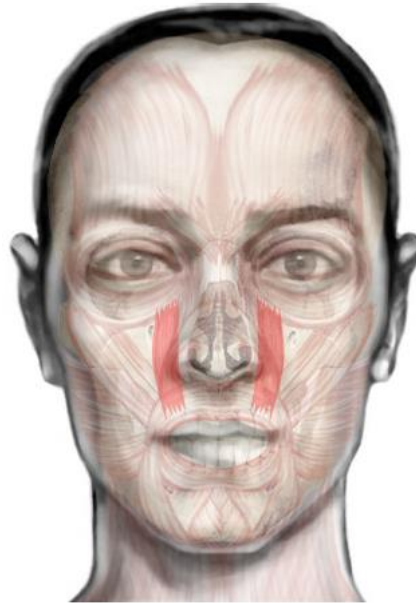

Figure 50: Location of the Caninus

In the composition of facial expression the caninus raises the upper lip, exposing the canine tooth and drawing the corner of the mouth back. It is associated with aggressive facial expressions. It is also used in producing a "contemptuous smile". (Faigin, 2008) , (Boulogne, 1990) & (Standring & Gray, 2008). The action of the caninus pictured in Figure 5.

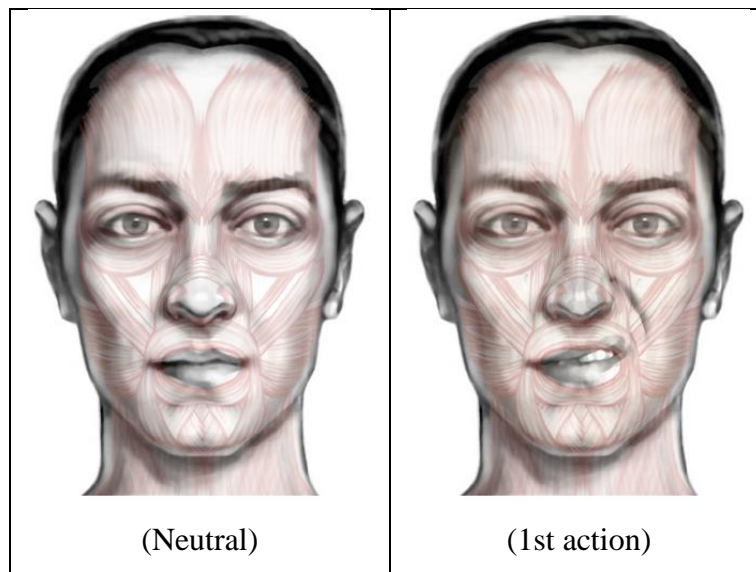

Figure 51: Actions of the Caninus

4.3.3. Levator Labii Superioris (or Quadratus Labii Superioris)

The Levator Labii Superioris muscle is a broad muscle, the origin of which extends from the side of the nose to the Zygomatic bone (shown in Figure 6).

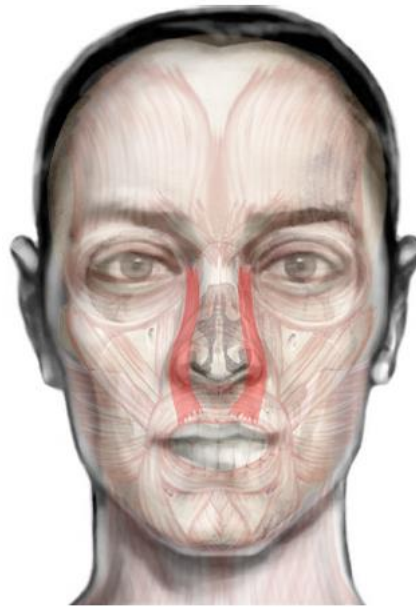

Figure 52: Location of the Levator Labii Superioris.

In the composition of facial expression it raises a portion of the upper lip and the side of the nose (Standring & Gray, 2008). The actions of the Levator Labii Superioris are pictured in Figure 7.

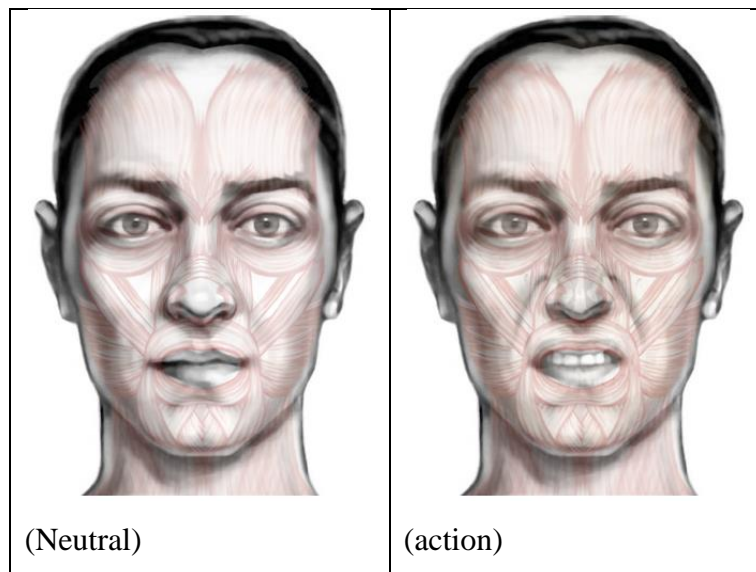

Figure 53: Actions of the Levator Labii Superioris

The Levator Labii Superioris is used to perform the following actions (Faigin, 2008) , (Boulogne, 1990):

- show displeasure;
- show grief;
- weep.

A set of baseline changes to EMG levels was found for different emotions by Vrana (Scott R. Vrana, 1993). These findings may have differed from other results because of the experimental methodology. Participants were given an emotional sentence and asked to imagine the sentence as if they were actually in the situation. This may have some effects that do not occur in experiments that use a stimulus to induce emotion. Vrana's results for the Corrugator Supercilii are shown in Figure 84.

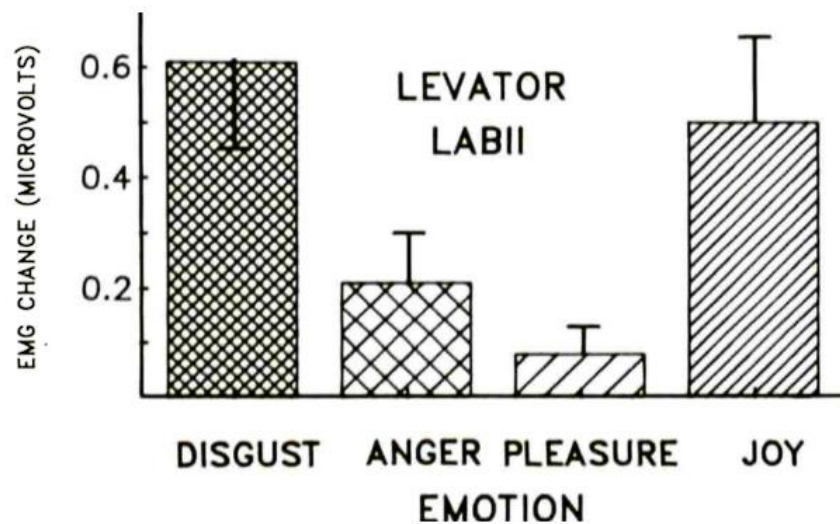

Figure 54: EMG change from baseline and standard errors in response to emotional imagery.

4.3.4. **Zygomaticus Minor**

The Zygomaticus Minor muscle, shown in Figure 8, is used in controlling facial expression. It originates on the Zygomatic bone and then inserts on the upper lip (Standring & Gray, 2008).

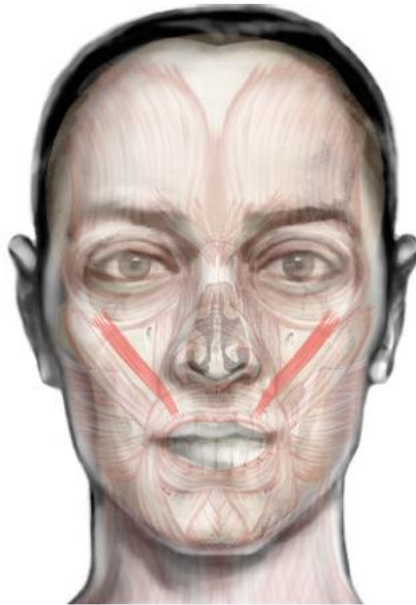

Figure 55: Location of the Zygomaticus Minor.

In the composition of facial expression it raises a portion of the upper lip and the side of the nose. (Faigin, 2008) , (Boulogne, 1990). The actions of the Zygomaticus Minor are pictured in Figure 9.

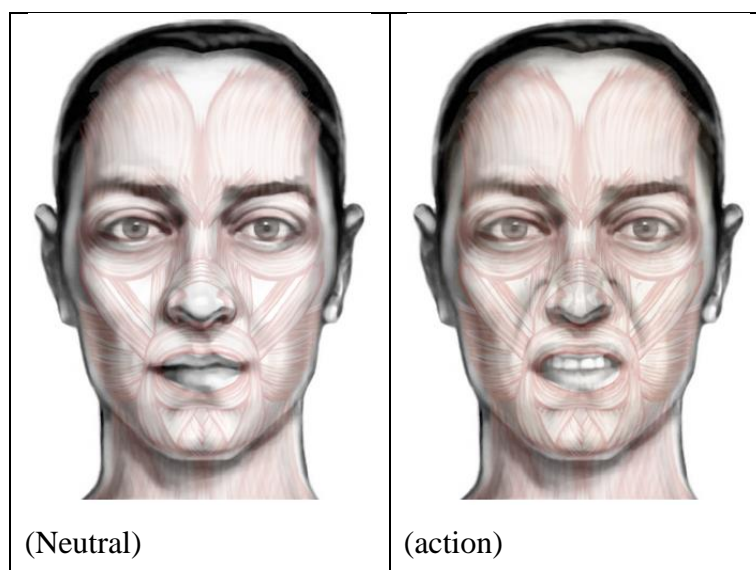

Figure 56: Actions of the Zygomaticus Minor.

The Zygomaticus Minor is used to perform the following actions (Faigin, 2008), (Boulogne, 1990):

- Sadness;
- Grief;
- As part of a smile.

4.3.5. **Zygomaticus Major**

The Zygomaticus Major muscle is used in controlling facial expression. Its purpose is to draw the angle of the mouth (Faigin, 2008), (Boulogne, 1990). Its location is shown in Figure 10.



Figure 57: Location of the Zygomaticus Major.

In the composition of facial expression it lifts the corners of the mouth to assist in forming smiles (Faigin, 2008), (Boulogne, 1990). The actions of the Zygomaticus Major are pictured in Figure 11.

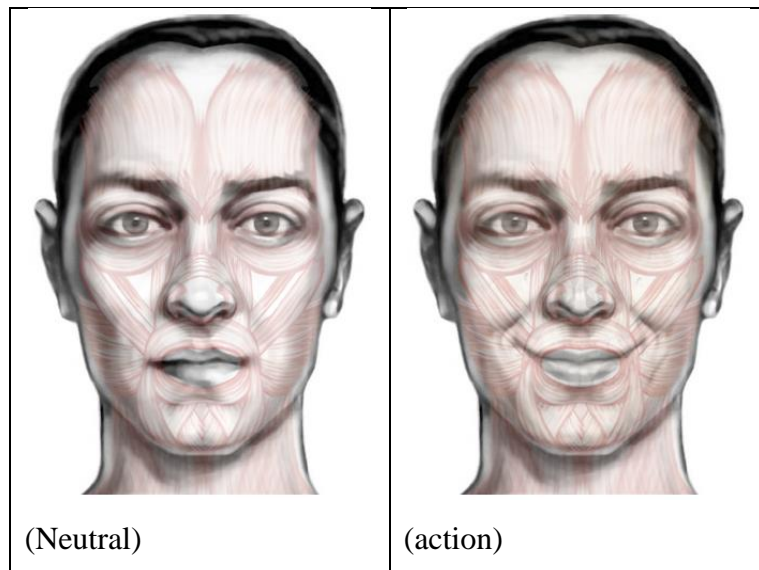

Figure 58: Actions of the Zygomaticus Major.

The Zygomaticus Major is used to perform the following actions (Faigin, 2008) , (Boulogne, 1990):

- Expressing happiness;
- Smiling.

Schmidt et al., (Schmidt, Ambadar, Cohn, & Reed, 2006) have studied the motion of the Zygomaticus Major in relation to posed and genuine smiles, an example participant is shown in Figure 59. Examining real and posed smiles generated by 87 female participants they concluded that deliberate smile onsets were faster and larger in amplitude while the offsets were faster and larger in amplitude. A summary of their results is in Table 8.

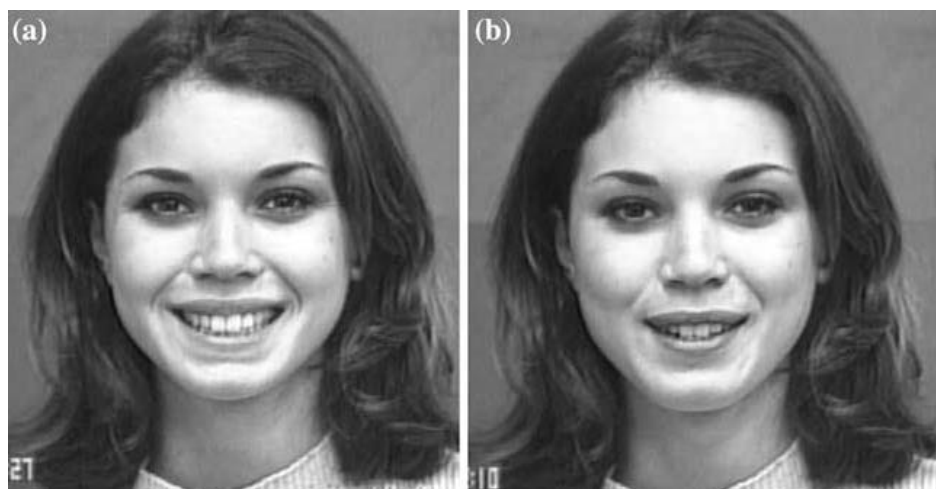

Figure 59: Facial expression of a Smile (A) posed (b) spontaneous (Schmidt et al., 2006)

Table 8: Results for Zygomaticus Major onsets and offsets in real and posed smiles. (Schmidt et al., 2006)

Lip Corner Movement and Asymmetry in Deliberate and Spontaneous Smiles ($n = 64$)

	Smile onset				Smile offset			
	Deliberate		Spontaneous		Deliberate		Spontaneous	
	<i>M</i>	<i>SD</i>	<i>M</i>	<i>SD</i>	<i>M</i>	<i>SD</i>	<i>M</i>	<i>SD</i>
Duration	.555	.169	.591	.259	.643*	.173	.555	.251
Maximum Speed	.030**	.011	.012	.007	.024**	.013	.012	.009
Amplitude	.187**	.050	.094	.054	.142**	.065	.083	.054
Asymmetry of Duration	.022	.125	-.017	.225	.007	.245	-.014	.258
Asymmetry Maximum Speed	.0002	.012	.0009	.008	-.001	.013	-.0002	.007
Asymmetry Amplitude	.005	.063	.002	.044	-.002	.058	-.0016	.036

* $p < .05$, ** $p < .01$.

Working also with angry facial expressions, Achaibou et al. (Achaibou, Pourtois, Schwartz, & Vuilleumier, 2008) conducted a study where participants were shown 10 frames of a morphing facial expression with increasing emotional intensity. Each frame appeared for 40 ms with the last one remaining for 1100ms. The mean Zygomaticus Major EMG responses to happy and angry facial animations are shown in Figure 60. The responses are consistent with the participant pulling the same face they are observing, but after a delay of 500ms. These findings are attributed to facial mimicry (Dimberg & Thunberg, 1998).

A set of baseline changes to EMG levels was found for different emotions by Vrana (Scott R. Vrana, 1993). These findings may have differed from other results because of the experimental methodology. Participants were given an emotional sentence and asked to imagine the sentence as if they were actually in the situation. This may have some effects that do not occur in experiments that use a stimulus to induce emotion. Vrana's results for the Corrugator Supercilii are shown in Figure 61.

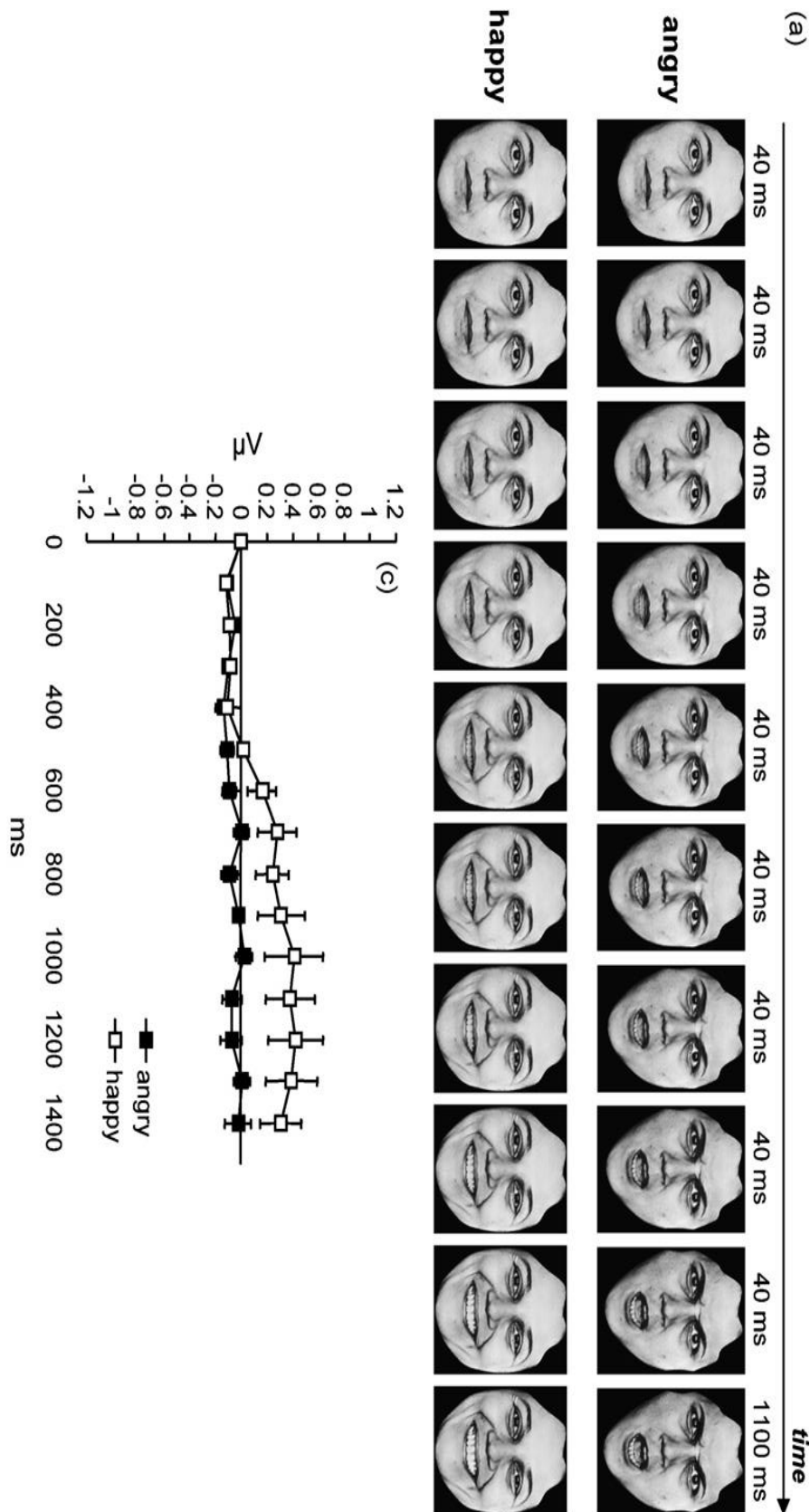

Figure 60: Mean Zygomaticus Major EMG Responses to Happy and Angry Facial Animations. (Achaibou et al., 2008)

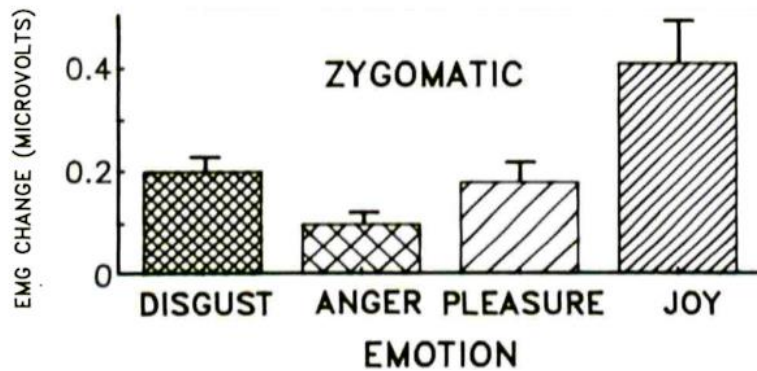

Figure 61: EMG change from baseline and standard errors in response to emotional imagery.

4.3.6. Risorius

The Risorius is a narrow bundle of fibres that arises in the fascia and inserts onto the skin at the edge of the mouth (Standring & Gray, 2008). Its location is shown in Figure 12.

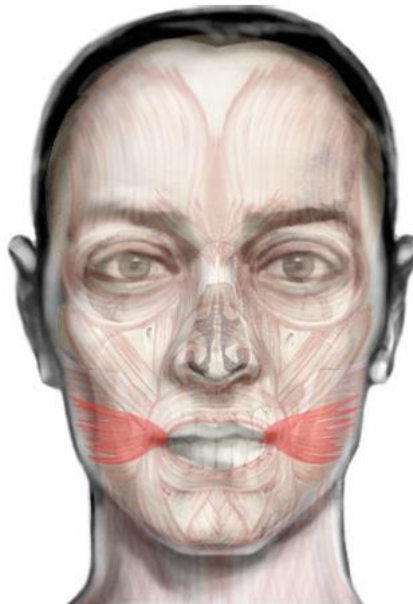

Figure 62: Location of the Risorius.

In the composition of facial expression the risorius retracts the angle of the mouth to produce a smile. The smile produced if only this muscle is involved looks false or ironic (Faigin, 2008) & (Boulogne, 1990). The actions of the risorius are pictured in Figure 63.

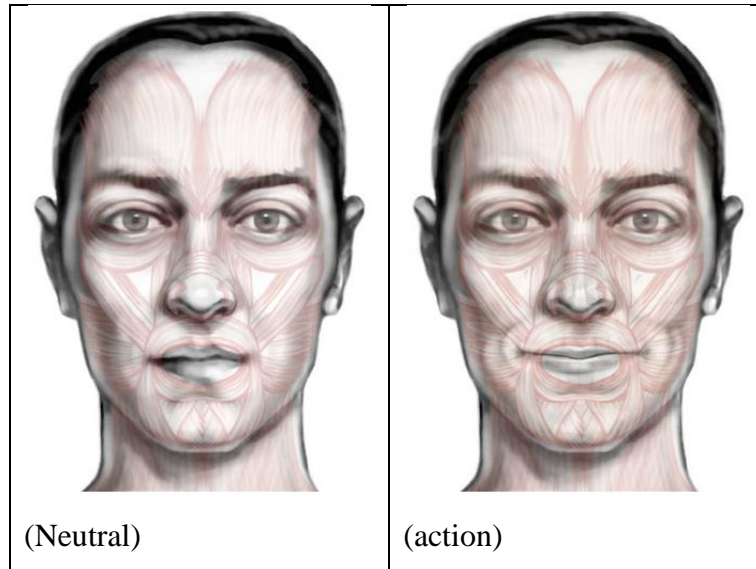

Figure 63: Actions of the Risorius.

The risorius is used to perform the following actions (Faigin, 2008) & (Boulogne, 1990):

- As part of a smile;
- To express an ironic smile;
- Used when a person gives a deliberate (false) smile.

4.3.7. **Buccinator**

The Buccinator is a quadrilateral shaped muscle behind the cheeks (Standring & Gray, 2008). Its location is shown in Figure 14.



Figure 64: Location of the Buccinator.

In the composition of facial expression the Buccinator pulls back the edge of the mouth and flattens the cheeks. The actions of the Buccinator are pictured in Figure 15.

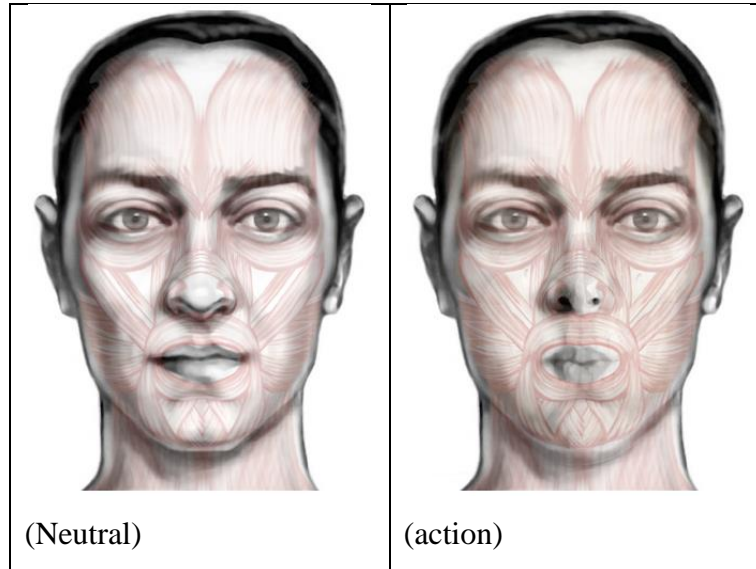

Figure 65: Actions of the buccinator.

The buccinator is used to perform the following actions (Faigin, 2008), (Boulogne, 1990):

- Blowing air (by the mouth);
- To create a contemplative contraction of the lips;
- Expressions of self control;
- Expressions of self resignation.

4.3.8. **Quadratus Labii Inferioris (Depressor Labii Inferioris)**

The Quadratus Labii Inferioris is a facial muscle used to lower the bottom lip (Standing & Gray, 2008). Its location is shown in Figure 16.

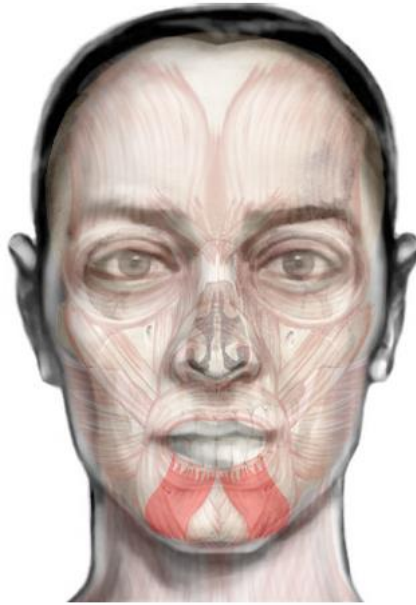

Figure 66: Location of the Quadratus Labii Inferioris.

In the composition of facial expression the Quadratus Labii Inferioris pushes out and down the lower half of the lip. The actions of the Quadratus Labii Inferioris are pictured in Figure 17.

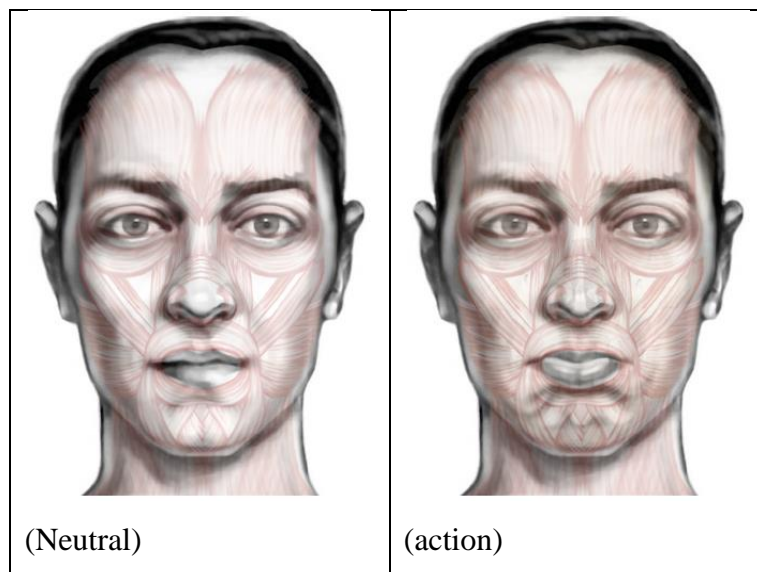

Figure 67: Actions of the Quadratus Labii Inferioris.

The Quadratus Labii Inferioris is used to perform the following actions (Faigin, 2008), (Boulogne, 1990):

- Expressing Anger;
- Expressing Misfortune;
- Used by children before they cry.

4.3.9. Depressor Anguli Oris (Triangularis)

The Depressor Anguli Oris is a muscle connecting the mandible and the mouth (Standing & Gray, 2008). Its location is shown in Figure 18.

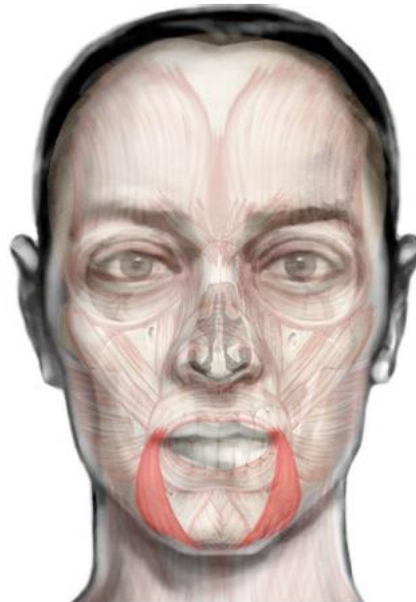

Figure 68: Location of the Depressor Anguli Oris.

In the composition of facial expression, the Depressor Anguli Oris associated strongly with frowning and is essential in displaying scorn. Its job is the opposite of the Zygomaticus Major in that it draws the edges of the mouth down. The actions of the Depressor Anguli Oris are pictured in Figure 19.

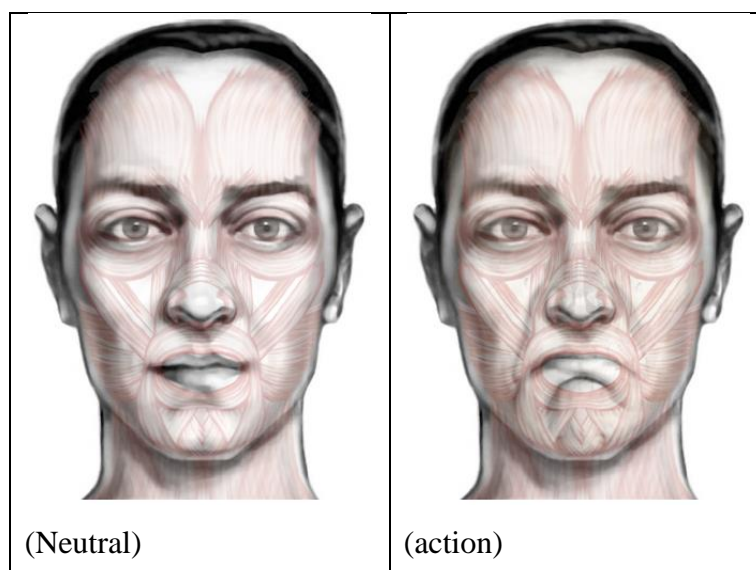

Figure 69: Actions of the Depressor Anguli Oris.

The Depressor Anguli Oris is used to perform the following actions (Faigin, 2008), (Boulogne, 1990):

- Display scorn;
- Frown;
- Show disgust;
- Show disapproval.

4.3.10. **Mentalis**

The Mentalis is located at the front of the chin. It raises and pushes out the lower lip, causing wrinkling of the chin (Standring & Gray, 2008). Its location is shown in Figure 12.

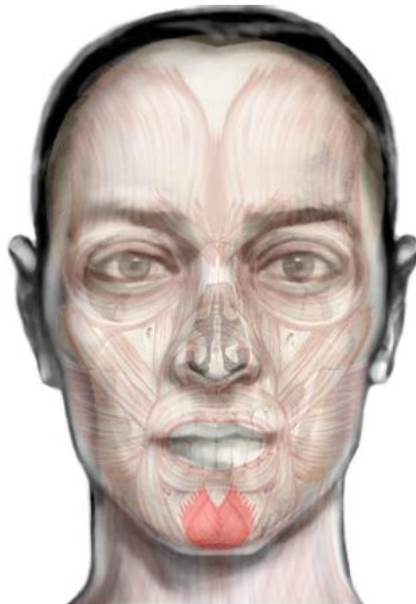

Figure 70: Location of the Mentalis.

In the composition of facial expression the Mentalis wrinkles the chin. The actions of the Mentalis are pictured in Figure 71.

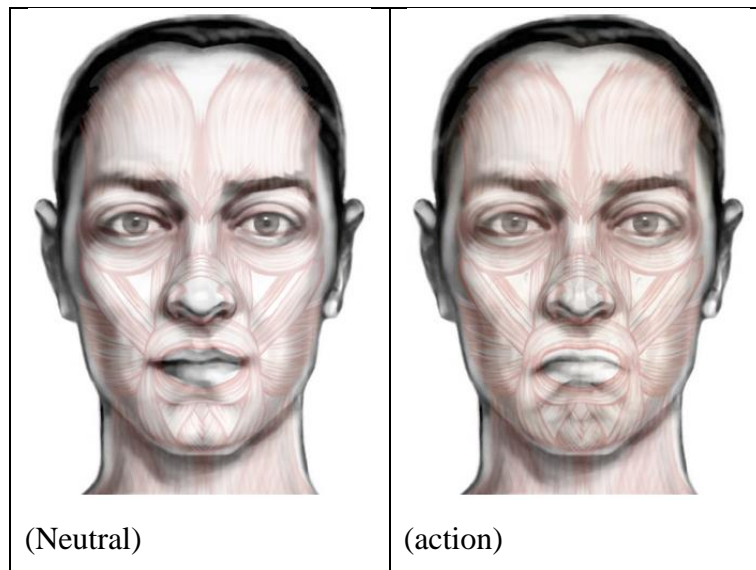

Figure 71: Actions of the Mentalis.

The Mentalis is used to perform the following actions (Faigin, 2008), (Boulogne, 1990):

- Grimace;
- Show doubt;
- Show displeasure.

4.3.11. **Risorius**

The Risorius is located in the cheeks and sits parallel to, and on top of, the Buccinator. Its action is similar to the buccinators but applied more to the ends of the mouth (Standring & Gray, 2008). Its location is shown in Figure 12.

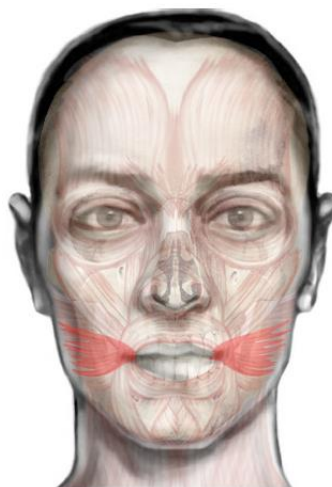

Figure 72: Location of the Risorius.

In the composition of facial expression the Risorius works with the Zygomaticus Major in order to produce an ironic smile which appears somewhat false and keeps the lips closed (Faigin, 2008), (Boulogne, 1990). Its action is shown in Figure 73.

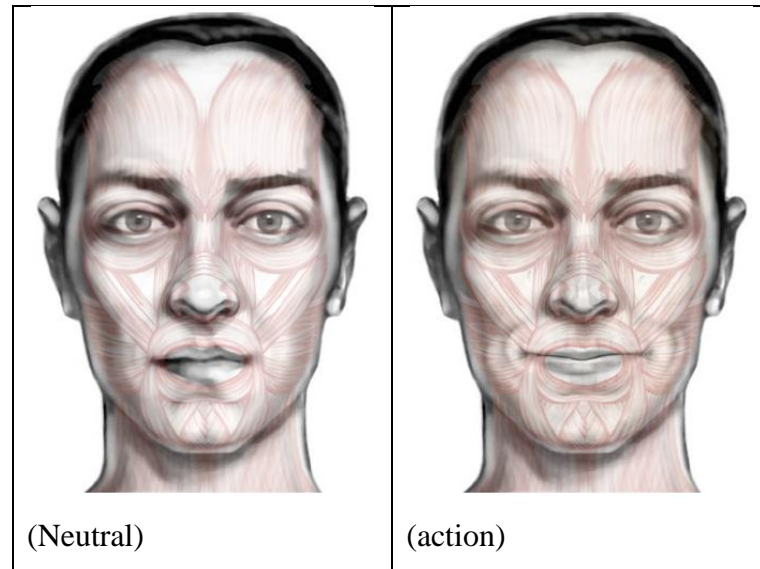

Figure 73: Actions of the Risorius.

4.3.12. **Platysma**

The Platysma is a broad sheet of muscle arising from the pectoral (chest) and deltoid (shoulder) muscles and covering the sides of the neck and the underside of the chin (Standring & Gray, 2008). Its location is shown in Figure 22.

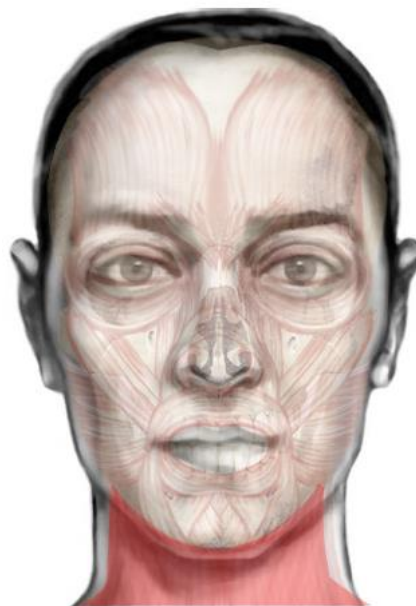

Figure 74: Location of the Platysma.

In the composition of facial expression the Platysma depresses (and wrinkles) the skin of the lower face. It reinforces the actions of the Mentalis and the Depressor Anguli Oris. The actions of the Platysma are pictured in Figure 23.

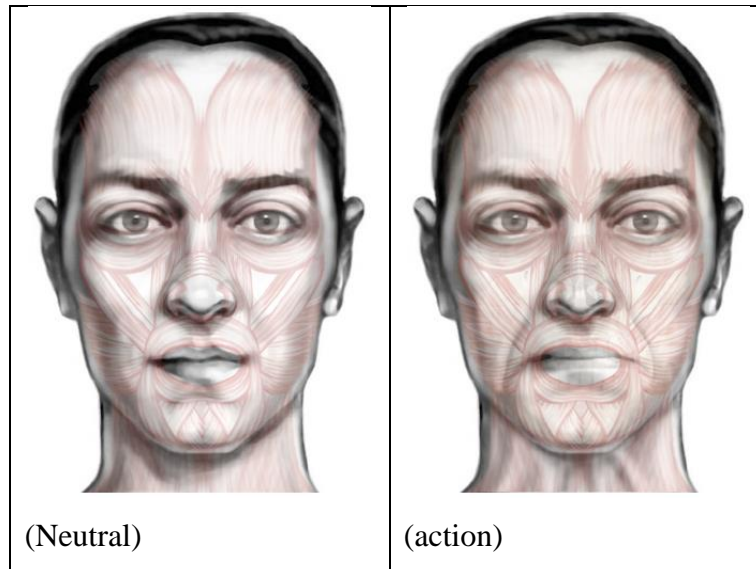

Figure 75: Actions of the Platysma.

The Platysma is used to reinforce the Mentalis in displaying the following actions (Faigin, 2008), (Boulogne, 1990):

- Grimace;
- Show doubt;
- Show displeasure.

4.4 Physiological Signals (EMG) of the Eyes

The mimetic muscles of the eye are a good candidate for EMG investigation because they are often used in expressing emotions. There are also fewer muscles involved which make signals examined less prone to interference from other muscles. The eye muscles, while not as multipurpose as the mouth muscles, still do some actions not associated with emotion, such as regular blinking, squinting to adjust vision or light tolerance.

This area of the face is very important to emotion research as we don't have as much motor control over it as we do other parts of the face (Penfield & Rasmussen, 1950)

and thus it is more likely not to be involved in posed expressions made to conform to social expectations. A relevant depiction of this is shown in Figure 76.

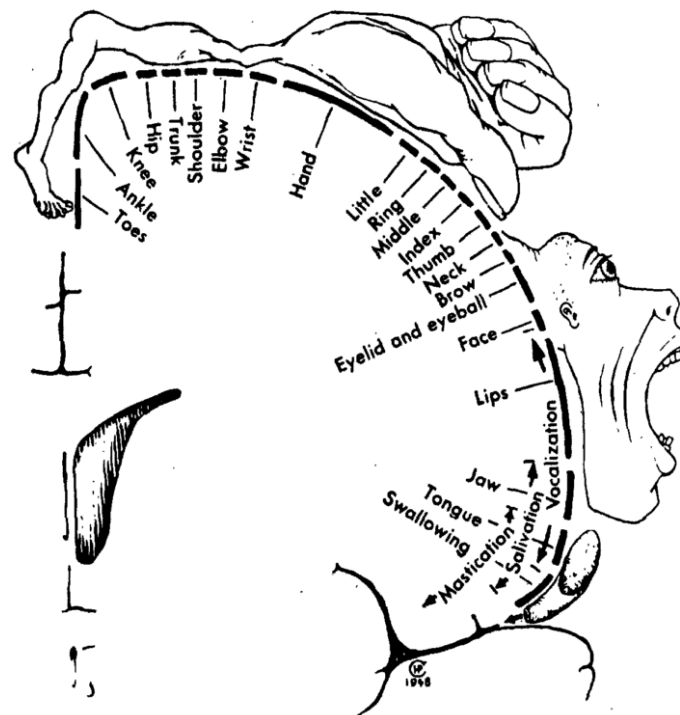

Figure 76: The primary motor strip of the cerebral cortex (Penfield & Rasmussen, 1950). The relative proportion of cortical tissue controlling the muscles of the body is illustrated by the cartoon; and more precisely by the length of the dark lines. Note the size of the mouth in proportion to the rest of the face.

An additional advantage to EMG in this region was found by Cacioppo et al., (Cacioppo, Petty, Losch, & Kim, 1986) who conducted a study with 12 participants that suggested EMG activity over the brow, eye, and cheek muscle regions could detect emotional responses not observable under normal social conditions.

There are primarily four muscles which are used in creating expressions with the eyes and eyebrows that can be observed using EMG:

- Frontalis;
- Corrugator Supercilii;
- Orbicularis Oculi;
- Procerus.

In this section we will review the function and related literature on the emotional responses of these muscles.

4.4.1. **Frontalis**

The Frontalis is the anterior belly of the Occipitofrontalis (also called the Epicranius) which stretches over the scalp (Standring & Gray, 2008). The poster belly, known as the Occipitalis, is not involved in facial expression. Its location is shown in Figure 77.

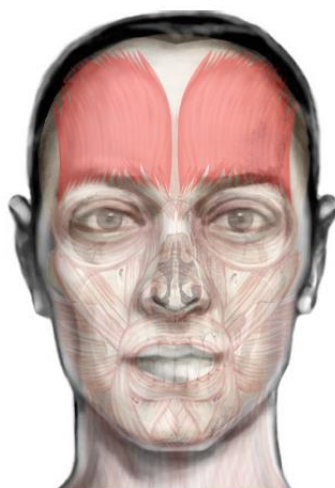

Figure 77: Location of the Frontalis

The Frontalis is used to raise and lower the eyebrows and aside from emotional facial expressions it's been linked to concentration levels and task difficulty. The Frontalis is used in displaying (Faigin, 2008), (Boulogne, 1990):

- Admiration;
- Astonishment;
- Confusion;
- Fear;
- Surprise;
- Startle reflex.

The actions of the Frontalis are shown in Figure 78.

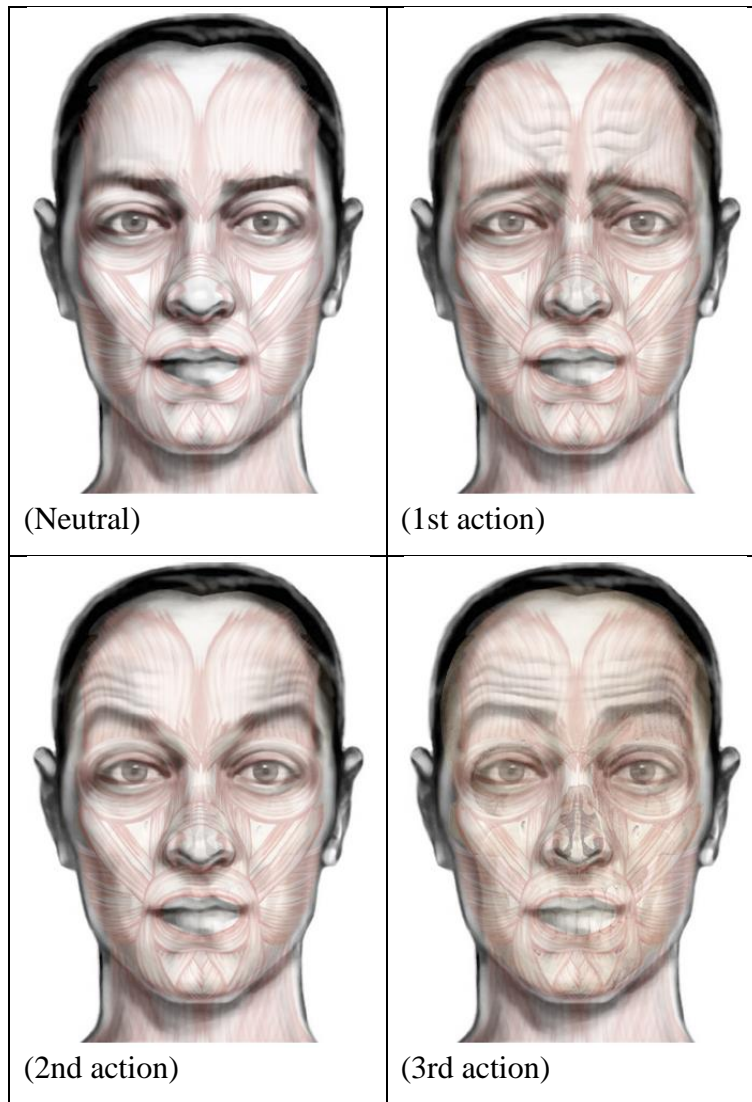

Figure 78: Actions of the Frontalis

Scheirer et al., (Scheirer, Fernandez, & Picard, 1999) used two Piezo sensors on the Frontalis to perform classification of posed expressions of confusion and interest. The system performed with 74% accuracy. Their sensor placement is shown in Figure 79.

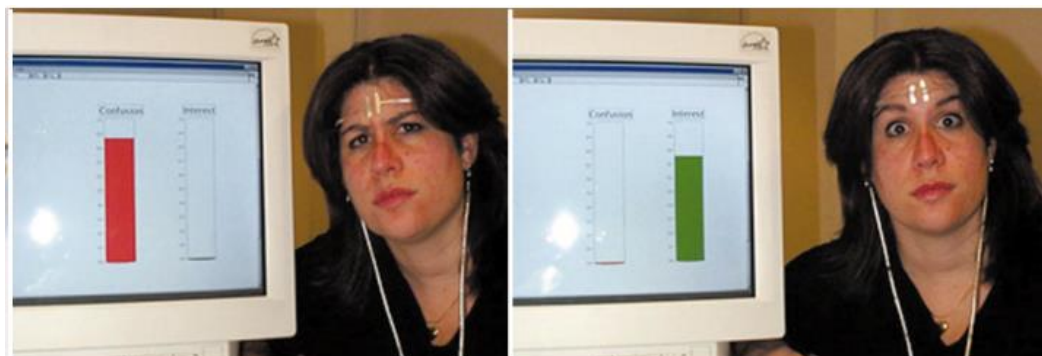

Figure 79: "Expression Glasses" (Scheirer et al., 1999)

4.4.2. **Corrugator Supercilii**

The Corrugator Supercilii is a small narrow muscle sitting above the Oculus Oris and below the Frontalis (Standing & Gray, 2008). Its location is shown in Figure 80.

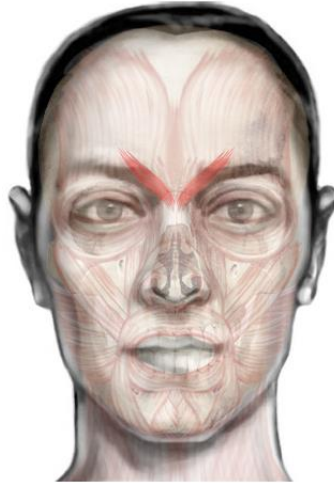

Figure 80: Location of the Corrugator Supercilii

The Corrugator Supercilii pulls the eyebrows inward and downward. It is used to form many negative facial expressions as well as to draw the eyebrows in to shield the eyes from sun glare. Its action, shown in Figure 81, is also responsible for the formation of vertical wrinkles in the brow.

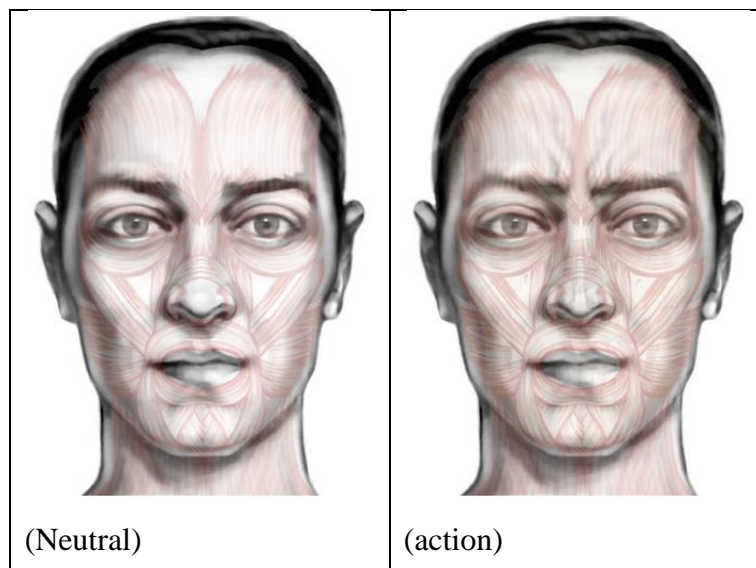

Figure 81: Actions of the Corrugator Supercilii

The Corrugator Supercilii is used primarily to display expressions of (Faigin, 2008), (Boulogne, 1990):

- Desperation;
- Displeasure;
- Impatience;
- Pain;
- Suffering;
- Rage;
- Unhappiness;
- Effort (physical and mental).

Hess, Philippot and Blairy (1998) conducted two studies manipulating (a) the emotional Valence of the stimuli (angry vs..happy faces) and (b) stimulus presentation in blocks of the same emotional nature vs. random order. Their work examining EMG activity for people looking at slides of human faces gave the following insights:

“...when judging expressions of anger participants showed more Corrugator Supercilii activity than when judging expressions of happiness. Further, participants show more Corrugator Supercilii activity when judging weak than when judging strong expressions of both happiness or anger. Also, participants showed less Corrugator Supercilii activity when judging strong happy expressions than when judging weak happy expressions.”

Relevant mean EMG activity is shown in Figure 82.

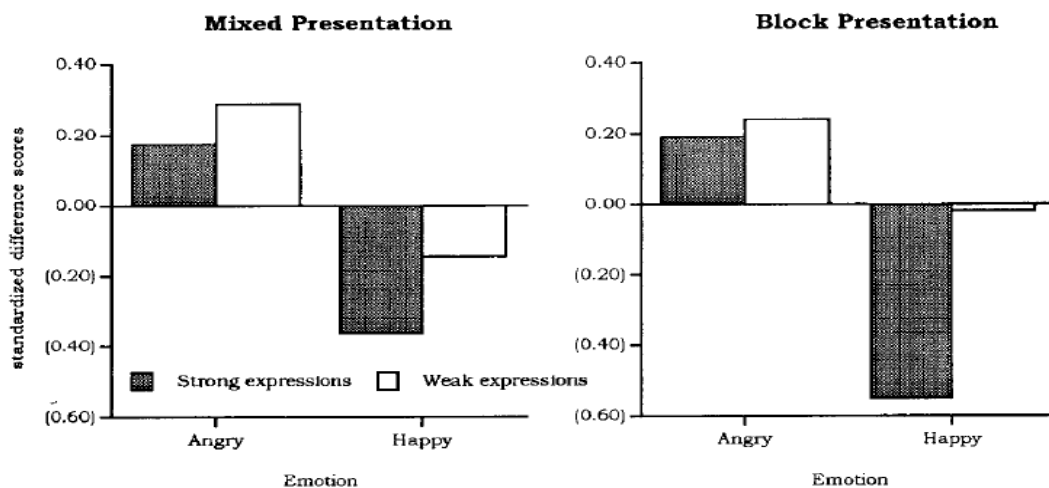

Figure 82: EMG activity(mean) for angry and happy faces. (Hess, Philippot & Blairy, 1998)

Achaibou et al., (Achaibou et al., 2008) conducted a study where participants were shown 10 frames of a morphing facial expression with increasing emotional intensity. Each frame appeared for 40 ms with the last one remaining for 1100ms. The mean Corrugator Supercilii EMG responses to happy and angry facial animations are shown in Figure 60. The responses are consistent with the participant pulling the same face they are observing, but after a delay of 200ms. These findings are attributed to facial mimicry (Dimberg & Thunberg, 1998).

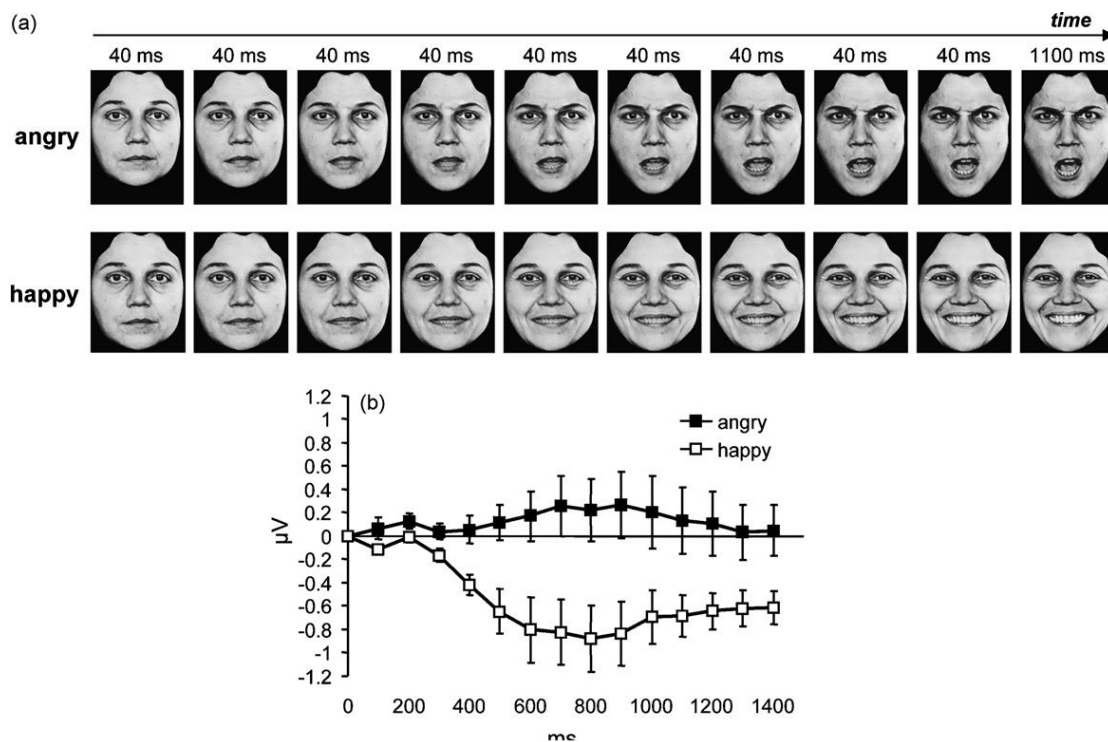

Figure 83: EMG responses to happy and angry facial animations (Achaibou et al., 2008)

It has been established (Cacioppo, Bush & Tassinary, 1992), (Cacioppo et al., 1986), (Dimberg, 1982) that the Corrugator Supercilii displays lower EMG activity when a participant is shown pleasant Stimuli and higher activity for negative stimuli. The results obtained by Cacioppo et al., in relation to this are shown in Figure 84.

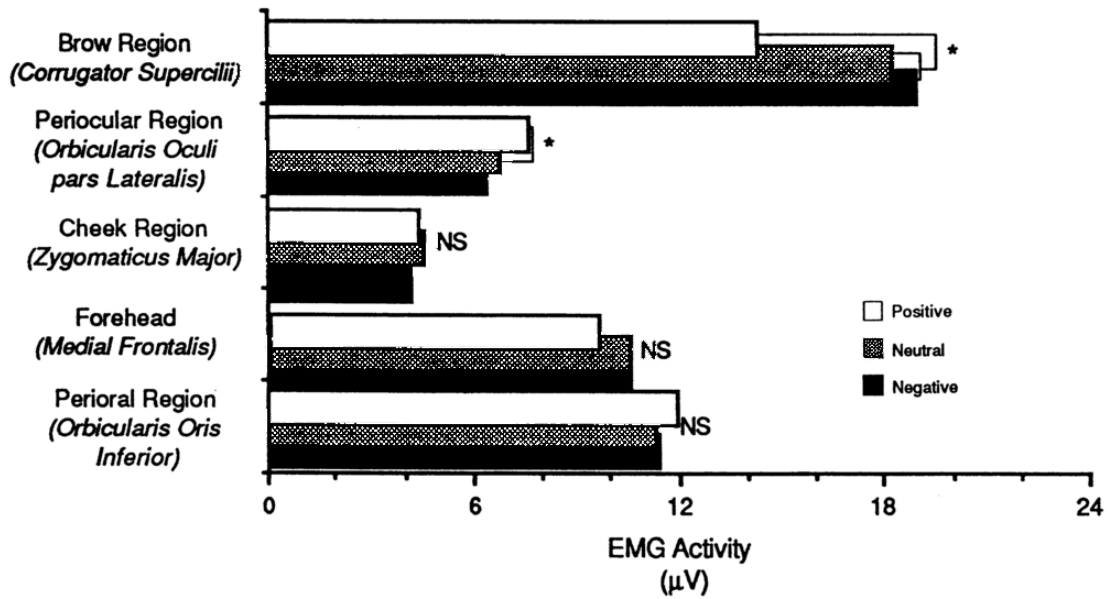

Figure 84: EMG Reactions to Assorted Stimulus (J. T. Cacioppo et al., 1992),. The *Corrugator Supercilii* shows higher activity for negative stimuli and lower for positive stimuli.

A set of baseline changes to EMG levels was found for different emotions by Vrana (Scott R. Vrana, 1993). These findings may have differed from other results because of the experimental methodology. Participants were given an emotional sentence and asked to imagine the sentence as if they were actually in the situation. This may have some effects that do not occur in experiments that use a stimulus to induce emotion. Vrana’s results for the *Corrugator Supercilii* are shown in Figure 85.

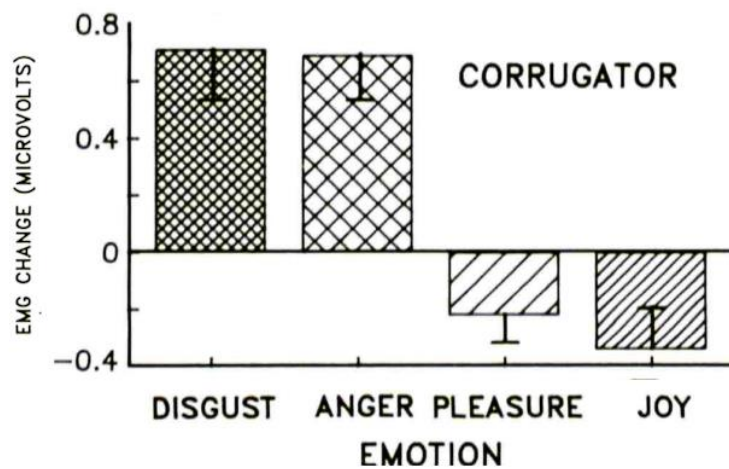

Figure 85: EMG change from baseline and standard errors in response to emotional imagery.

4.4.3. Orbicularis Oculi

The Orbicularis Oculi is responsible for closing or narrowing the eyelids (Standring & Gray, 2008). The muscle is a flat elliptical ring around the eye sockets as shown in Figure 86.



Figure 86: Location of the Orbicularis Oculi

The internal portion of the muscles opens or closes the eyelids. The lower portion projects the lower eyelid upwards and furrows the corners of the eyes. The Orbicularis Oculi can also pull the eyebrows downward (as opposed to the Frontalis which raises them). Finally, the muscle can also pull the skin around the eyes inward, causing squinting and wrinkling of the area. These actions are shown (in the same order mentioned) in Figure 87.

The muscle is involved in displaying (Faigin, 2008), (Boulogne, 1990):

- Joy;
- Sadness;
- Concentration;
- Attention.

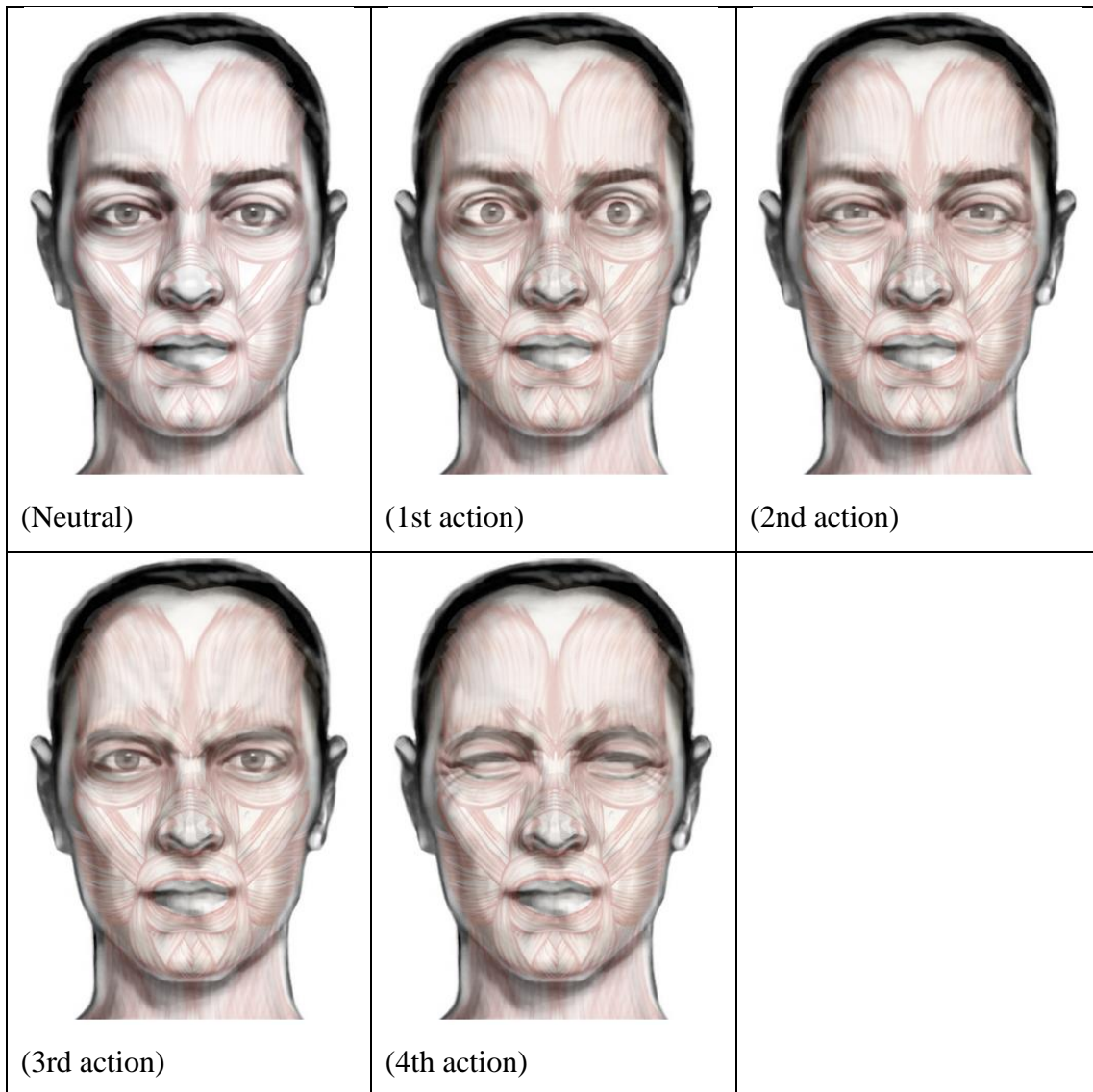

Figure 87: Actions of the Orbicularis Oculi.

It has been established (Cacioppo et al., 1992), (Cacioppo et al., 1986), (Dimberg, 1982) that the Orbicularis Oculi displays higher EMG activity when a participant is shown pleasant Stimuli and lower activity for negative stimuli. The results obtained by Cacioppo et al., in relation to this are shown in Figure 88.

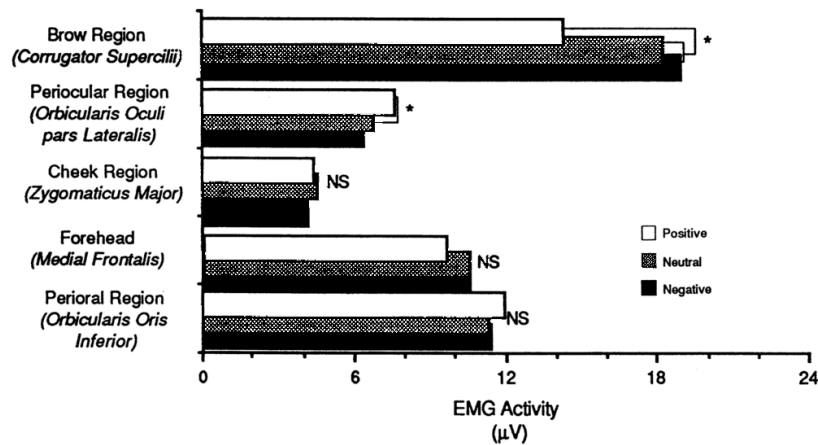

Figure 88: EMG Reactions to Assorted Stimulus (J. T. Cacioppo et al., 1992). The Orbicularis Oculi displays higher EMG activity when a participant was shown pleasant Stimuli, while the Corrugator Supercilii shows higher activity for negative stimuli.

Hess, Philippot and Blairy (1998) as mentioned in the review of the Corrugator Supercilii, conducted two studies manipulating (a) the emotional Valence of the stimuli (angry vs. happy faces) and (b) stimulus presentation in blocks of the same emotional nature vs. random order. In their work examining EMG activity for people looking at slides of human faces they found few Valence links except those due to facial mimicry; their participants showed more Orbicularis Oculi activity when exposed to happy than when exposed to angry faces. Relevant mean EMG activity is shown in Figure 82.

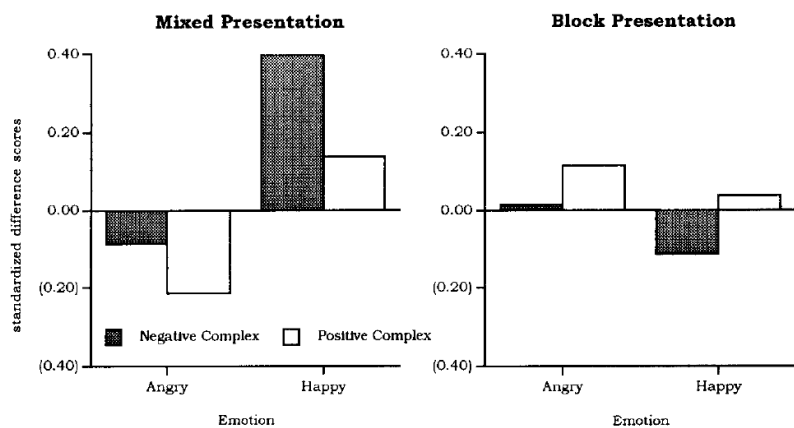

Figure 89: Orbicularis Oculi EMG activity (mean) for angry and happy stimulus. (Ursula et al., 1998)

The Orbicularis Oculi is also involved in the expression of laughter. A review paper by Willibald & Ekman which examined the expressive patterns of laughter in the face (Willibald & Ekman, 2001) showed a majority of authors identified it as being involved in laughter. The result table from the study is shown in

Table 2. Hypotheses and empirical findings regarding the involvement of facial muscles in laughter

Author(s)	upper face muscles			mid-face muscles					lower face muscles									
	1	2	3	4	5	6	7	8	9	10	11	12	13	14	15	16	17	18
<i>Hypotheses: laughter</i>																		
Bloch et al. (1987)					X	X	X											X
Darwin (1872)					X	X	X		X	X?								
Dearborn (1897)			X	X		X	X	X	X	X	X		X			X		
Hecker (1873)							X		X	X								
Heller (1902)					X	X	X						X					
Hjortsjö (1970)	X	X			X	X	X	X		X		X	X					X
Piderit (1867)							X	X	X			X		X				
Poeck and Pilleri (1963)					X		X				X			X				
Raulin (1900)					X?		X	X				X						
<i>Hypotheses: strong laughter</i>																		
Darwin (1872)			X		X	X	X		X	X?								
Heller (1902)	X	X	X	X	X	X	X		X				X					X
Piderit (1867)			X				X	X	X				X		X			
<i>Results: FACS-studies</i>																		
Grammer (1990)							X											
Keltner and Bonanno (1997)					X		X											-
Ruch (1990, 1994)					X	X	X											-
Ruch (1997)					X		X											-
<i>Results: EMG-studies</i>																		
Gallo and Palla (1995)																		X
Santibañez et al. (1986)														X				X
Sumitsuji (1967)	-	-	-		X		X		X				X	X	X	X		
Tanaka (1976)	-	-	-		X		X											X
Tanaka et al. (1991)	-	-	-		X		X		X				X					X
<i>Supressed laughter</i>																		
Tanaka (1976)	X	X			X		X											
<i>Pathological laughter</i>																		
Tanaka et al. (1991)	X	X	X		X		X		X				X					X
Yamada et al. (1994)			X															

Notes. 1=frontalis, pars medialis-raises the inner brows, producing horizontal furrows in the medial region of the forehead; 2=frontalis, pars lateralis-raises the outer brows, producing horizontal furrows in the lateral regions of the forehead; 3=corrugator supercilii-draws the brows together and downward, producing vertical furrows between the brows; 4=pyramidalis/procerus/depressor supercilii-pulls the medial part of the brows downward and may wrinkle the skin over the bridge of the nose; 5=orbicularis oculi, pars orbitalis-tightens the skin surrounding the eye causing crows-feet wrinkles; 6=orbicularis oculi, pars palpebralis-tightens the skin surrounding the eye causing the lower eyelid to raise; 7=zygomaticus major-pulls the lip comers up and back; 8=zygomaticus minor-deepens nasolabial furrow; 9=levator labii superioris/levator labii superioris, caput infraorbitalis-raises the upper lip and flares the nostrils, exposing the canine teeth; 10=levator labii superioris alaeque nasi-raises the center of the upper lip and flares the nostrils; 11=nasalis, pars alaris bzw. dilatores nasi-dilates nostrils; 12=buccinator-compresses and tightens the cheek, forming a dimple; 13=risorius-stretches lip comers straight to the side; 14=orbicularis oris-tightens, compresses, protrudes, or inverts the lips; 15=depressor anguli oris-pulls the lip comers downward; 16=mentalis-raises the chin and protrudes the lower lip; 17=masseter-adducts the lower jaw; 18=caninus/levator anguli oris-pulls the lip corner up sharply and puffs up cheeks. A "X" includes action of that muscle, a "-" means lowering of muscle tone. Authors either gave names or picture of muscles or a description of facial appearance from which the muscle action was then inferred utilizing the information provided by the *Facial Action Coding System* (Ekman & Friesen, 1978). An "?" was added when the muscle is not entirely clear from the description given.

Figure 90: Excerpt from (Willibald & Ekman, 2001) with the Orbicularis Oculi and Corrugator Supercilii related text highlighted.

4.4.4. Procerus

The Procerus is a small muscle located from the top of the nose in the region between the eyebrows, where its fibres merge with the Frontalis, extending down to the lower portion of the nasal bone (Standring & Gray, 2008). Its location is shown in Figure 91.

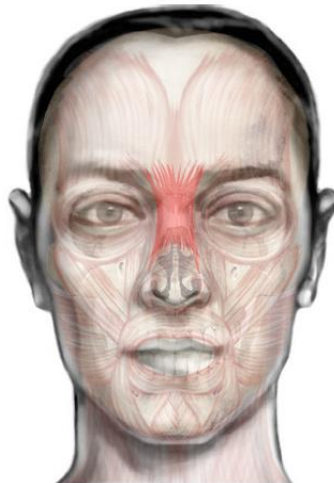

Figure 91: Location of the Procerus

In forming facial expression the Procerus pulls the skin between the facial muscles downward while also flaring the nostrils. This action is shown in Figure 92.

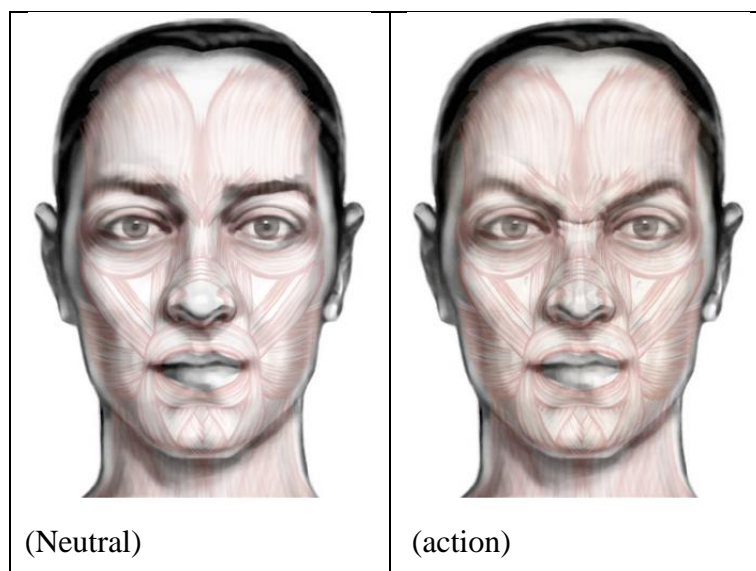

Figure 92: Actions of the Procerus.

4.5 Physiological Signals (EMG) of the Nose

There are two rhinal muscles which are used in creating expressions with the nose that can be observed using EMG:

- Nasalis Transversa;
- Nasalis Alaris.

In this section we will review the function and related literature on the emotional responses of these muscles.

4.5.1. Nasalis Transversa

The Nasalis Transversa is a triangular muscle that covers the lateral parts of the nose (Standring & Gray, 2008). Its location is shown in Figure 93.

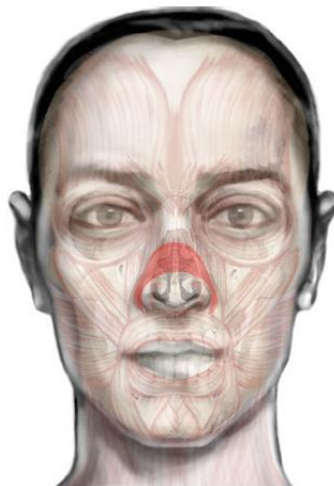

Figure 93: Location of the Nasalis Transversa.

In forming facial expressions the Nasalis Transversa elevates the wings of the nose and is involved in the “scrunching” of the nose. Its action is shown in Figure 94.

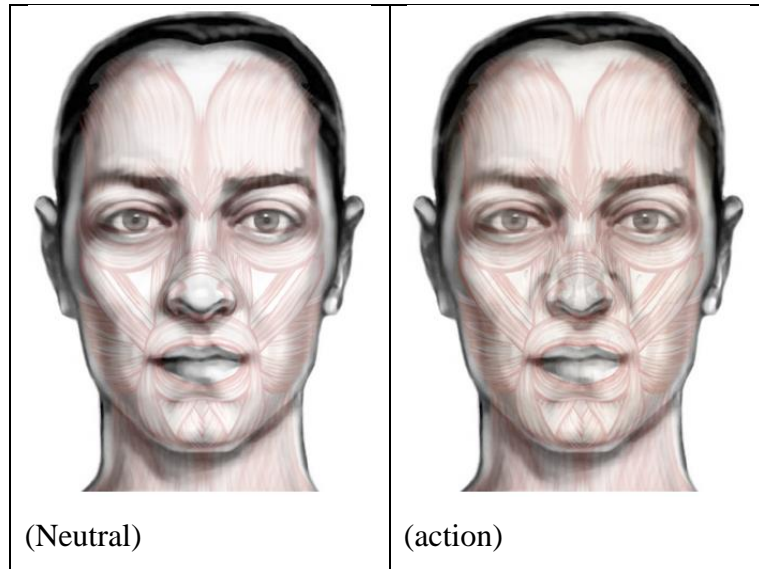

Figure 94: Actions of the Nasalis Transversa.

The Nasalis Transversa is used to display (Faigin, 2008), (Boulogne, 1990):

- Reactions to unpleasant smells;
- Rejection;
- Displeasure.

4.5.2. **Nasalis Alaris**

The Nasalis Alaris is located underneath the nose and is situated over the base of the Canine being partly covered by the Oculus Oris (Standing & Gray, 2008). Its location is shown in Figure 95.

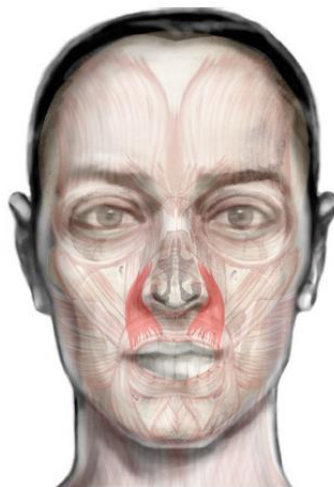

Figure 95: Location of the Nasalis Alaris.

In posing the face Nasalis Alaris moves the wings of the nose inward by moving the base of the nose inward and downward. It also (indirectly) pushes the lip downward. Its action is shown in Figure 96. There are no emotive expressions directly related to the Nasalis Alaris (Goldfinger, 1991), but it is involved with facial contortions that occur when someone is overcoming pain (Faigin, 2008), (Boulogne, 1990).

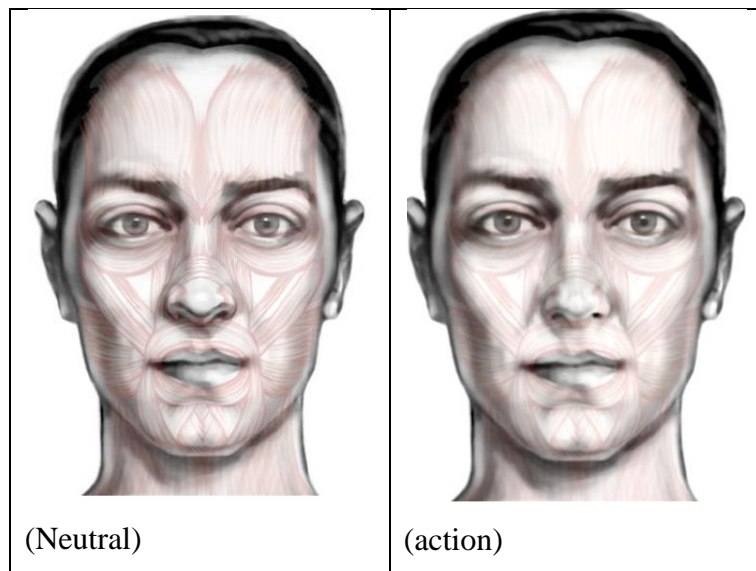

Figure 96: Actions of the Nasalis Alaris.

4.6 Summary of the Affective Capacity of the Mimetic Muscles

A limitation of facial EMG Data (as with other facial data) in examining the emotional state is that the human face also responds to a large variety of states unrelated to emotion. For example speech, mental fatigue/effort, anticipation of sensory stimuli, preparation of motor responses, startle reflexes and orienting responses; as covered in (A. V. Boxtel, 2010), (Or & Duffy, 2007), (Stekelenburg & Boxtel, 2002).

Summarising the information presented in this chapter by basic emotion, we can list facial muscle involvement in emotion as:

- Anger;
 - Corrugator supercilii, Levator palpebrae, superioris, Orbicularis oculi;
- Disgust;

- Levator labii superioris, Levator labii superioris, alaeque nasi;
- Fear;
 - Frontalis, Corrugator supercilii, Levator;
- Happiness;
 - Orbicularis oculi, Zygomaticus major;
- Sadness;
 - Frontalis, Corrugator supercilii, Depressor anguli oris;
- Surprise;
 - Frontalis, Levator palpebrae.

Having investigated a series of facial muscles for EMG analysis, we found the Corrugator Supercilii, which is associated with Anger, Fear and Sadness, to be a useful indicator of emotional state that was not heavily affected by either social display rules of emotion or other facial display mechanisms.

In the next chapter we will attempt to quantify the degree to which the muscles identified above might be useful in PPR by taking EMG recordings for various parts of the face during deliberate (posed) facial expressions. To be feasible for our study a muscle must produce a distinct pattern during display, of a specific emotion, that is not readily confused with patterns produced while other emotions are displayed.

5.0 Examination of Electromyography Results from Posed Facial Expressions

“Laughter is the sun that drives winter from the human face.”

-Victor Hugo (1802- 1885)

This chapter presents our initial experiments with EMG recording of facial muscles. It describes a series of facial EMG recordings that were taken from two participants to trial the sensor placements and ensure we could reproduce the results from the literature review. We also wished to judge signal morphology in general to estimate likely traits useful in distinguishing various (posed) facial expressions.

We trialled several placements specific to mimetic muscles identified in section 4.0 as highly significant in emotional content while not being regularly used for other non- emotional tasks. We also trialled some placements that spanned multiple muscles in order to attempt to utilise broader actions of muscle groups. The placements used were:

- Orbicularis Oris (Specific placement);
- Zygomaticus Major (Specific placement);
- Buccinator (Specific placement);
- Depressor Anguli Oris (Specific placement);
- Mentalis (Specific placement);
- Orbicularis Oculi (Specific placement);
- Frontalis (Specific placement);
- Suprahyoid Placement;
- Temporal Suprahyoid Placement;
- Temporal Masseter (Wide) Placement;
- Frontal (Wide) Placement

We also experimented with EMG placement diagonally across the neck (Vaiman, Eviatar, & Segal, 2004) to monitor swallowing. However we discovered two problems, which made the procedure unsuitable for our requirements:

1. The placement could not be made if the participant had a beard.
2. Going only on anecdotal evidence, we found the neck placement may be uncomfortable for the participant.

In this section we will review our trial experiments, which are based on posed (but not exaggerated) facial expressions.

5.1 EMG of the Orbicularis Oris

The Orbicularis Oris placement used was the left portion of the lower placement Boxtel (A. V. Boxtel, 2010). Two electrodes were placed 15mm apart just below the lower lip. The earth electrode was attached to the bony prominence of the scalp just below the hair line, as shown in Figure 97, artefacts were produced by any sort of mouth movement.

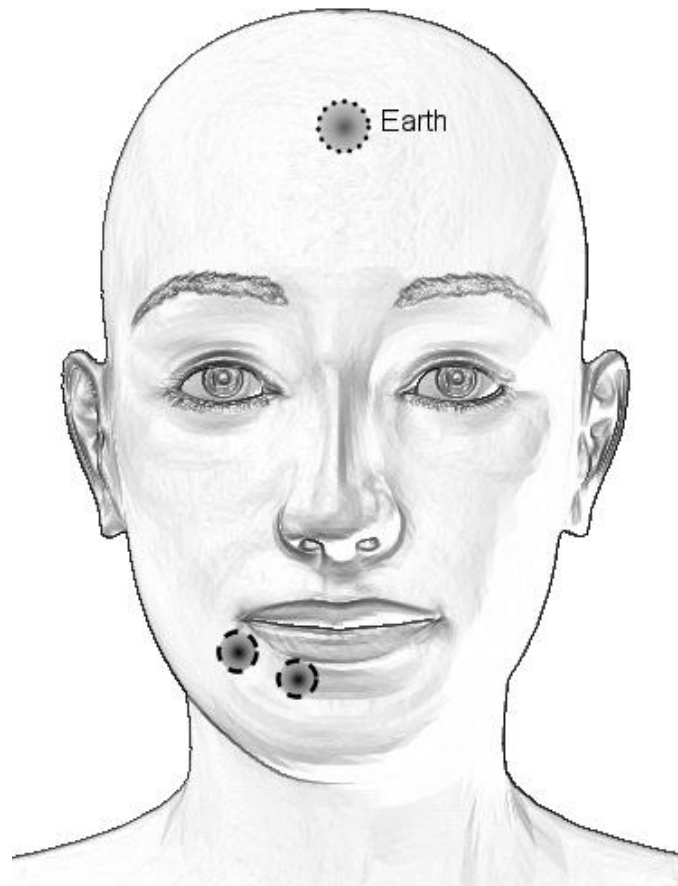

Figure 97: Orbicularis Oris Electrode Placement.

The testing of the Orbicularis Oris involved (A) A pursed smile with the lips closed. (B) A pensive biting of the lip. (C) Talking, a typical recording is shown in Figure 98. The smiles were distinct from a neutral action and distinguishable from general talking in that they did not reach the same maximum amplitudes.

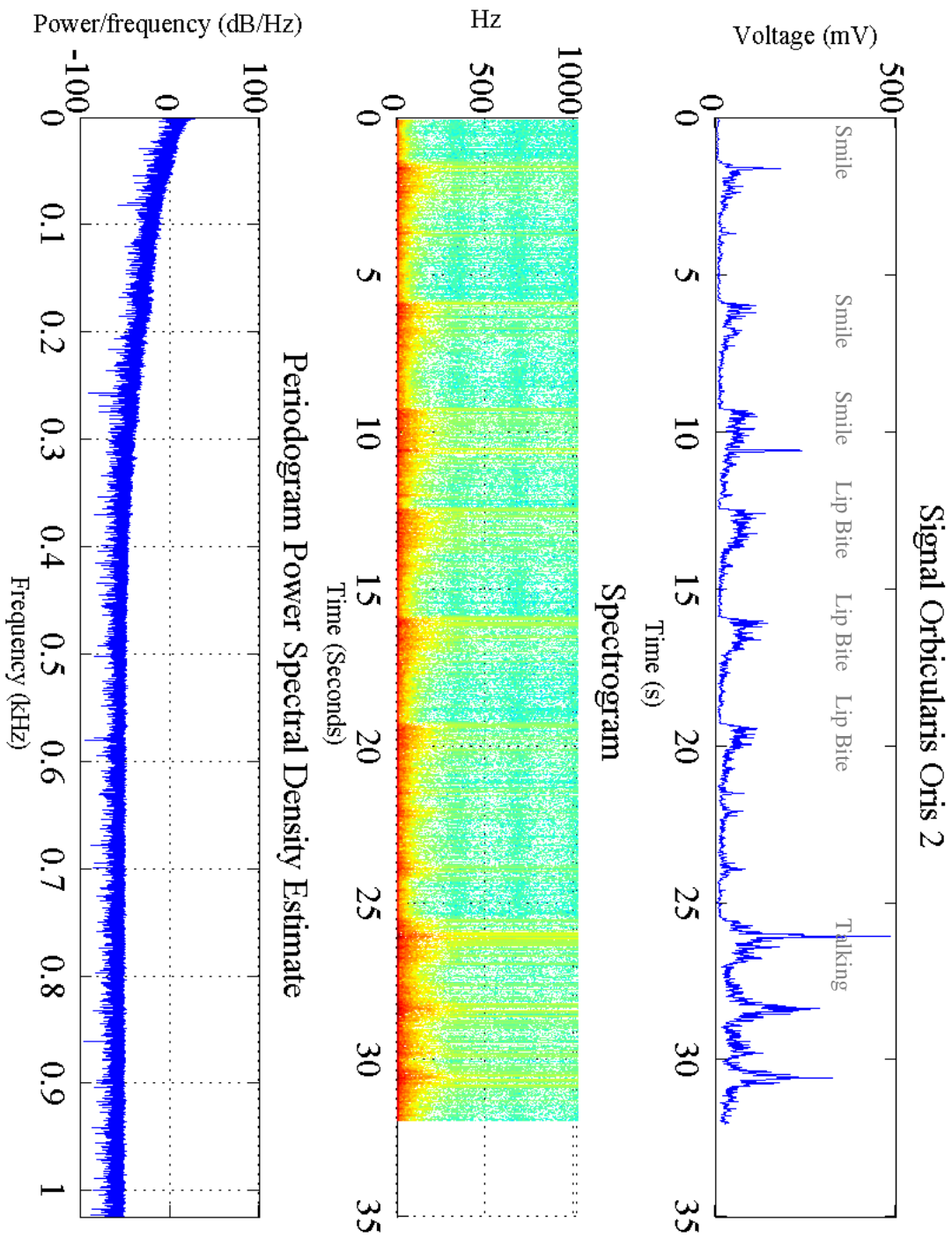

Figure 98: Typical EMG Recording for the Orbicularis Oris showing (A) a pursed smile with the lips closed. (B) A pensive biting of the lip. (C) Talking.

5.2 EMG of the Zygomaticus Major

The Zygomaticus Major is used in smiling, EMG observation was performed via a placement detailed by Cram et al., (1998) and Boxtel (2010). The placement used two electrodes placed 20mm apart following the muscle fibres of the Zygomaticus Major. The placement was made at the midpoint of the muscle and it uses an earth electrode at the bony prominence of the scalp just below the hair line, as shown in Figure 99. Actions known to produce artefacts include swallowing and talking.

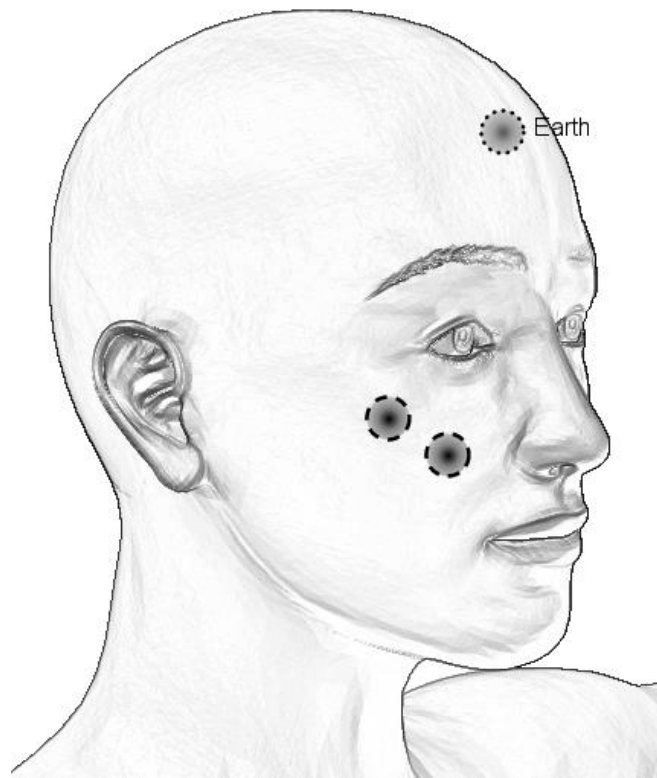

Figure 99: Zygomaticus Major Electrode Placement.

Testing of the Zygomaticus Major EMG recordings involved smiling and talking. Smiles were distinctly detectable as high amplitude regions maintained for the duration of the action. They were higher in amplitude, and had a greater spectral component, than general talking. A typical recording is shown in Figure 100.

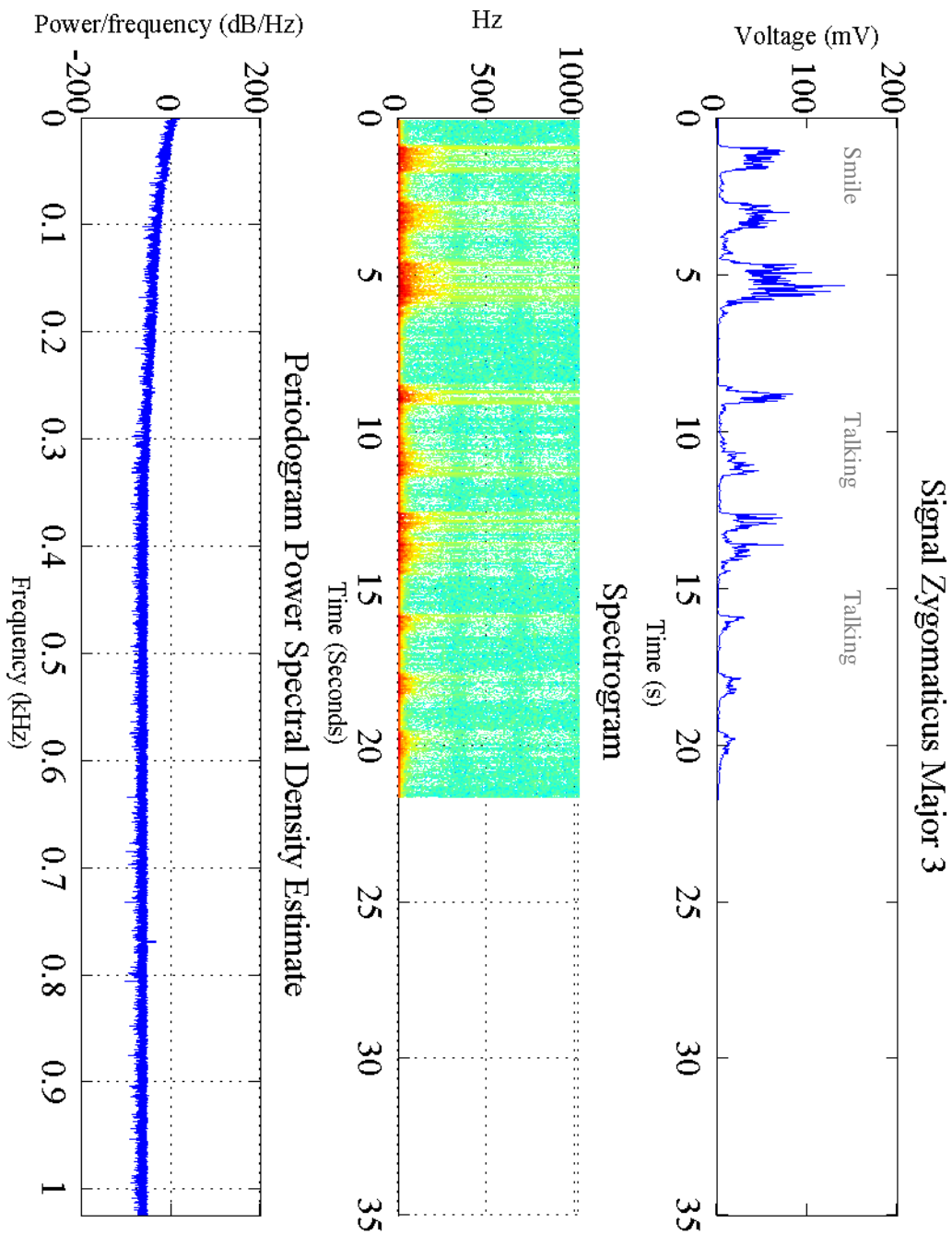

Figure 100: Zygomaticus Major EMG recordings showing smiling and talking.

5.3 EMG of the Buccinator

The Buccinator is used in smiling, blowing air through the lips, its observation was performed via a placement detailed by Cram et al., (1998). The placement used two electrodes placed 10mm apart following the muscle fibres of the Buccinator. The placement was made with both electrodes positioned laterally to the corner of the mouth and an earth electrode was placed at the bony prominence of the scalp just below the hair line, as shown in Figure 101. Actions known to produce artefacts include swallowing and talking.

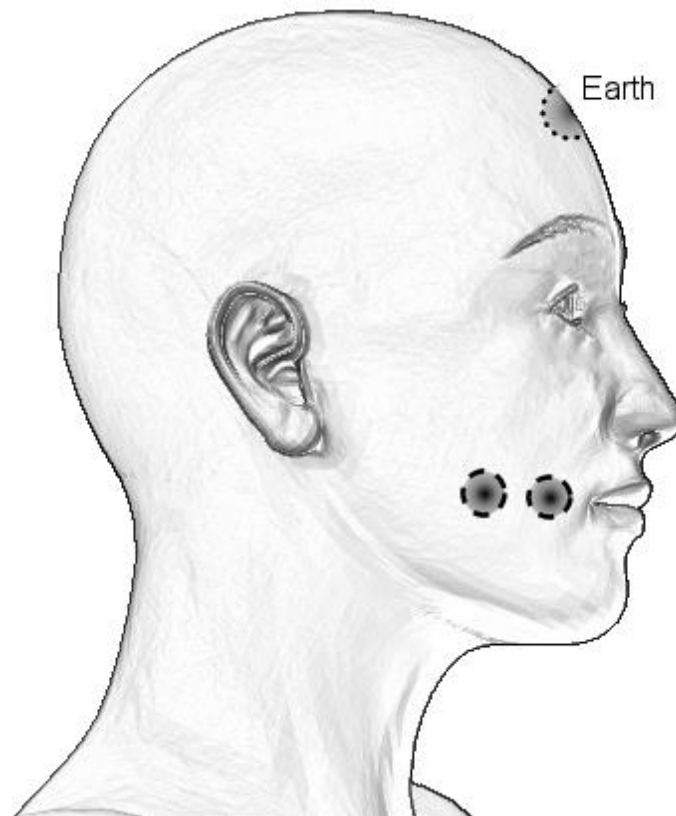

Figure 101: Buccinator Electrode Placement.

The EMG Tests involved (A) Blowing air through the lips in expressions of exasperation and self control. (B) Smiling. (C) Lips pursed in and expression of contemplative contraction. All these actions were very distinguishable. The blowing produced a small artefact with relatively low frequency components. The smile produced a region of slightly higher amplitude that contained higher frequencies. The pursing of the lips produced a region nearly double in amplitude to the other actions. A typical recording is shown in Figure 102.

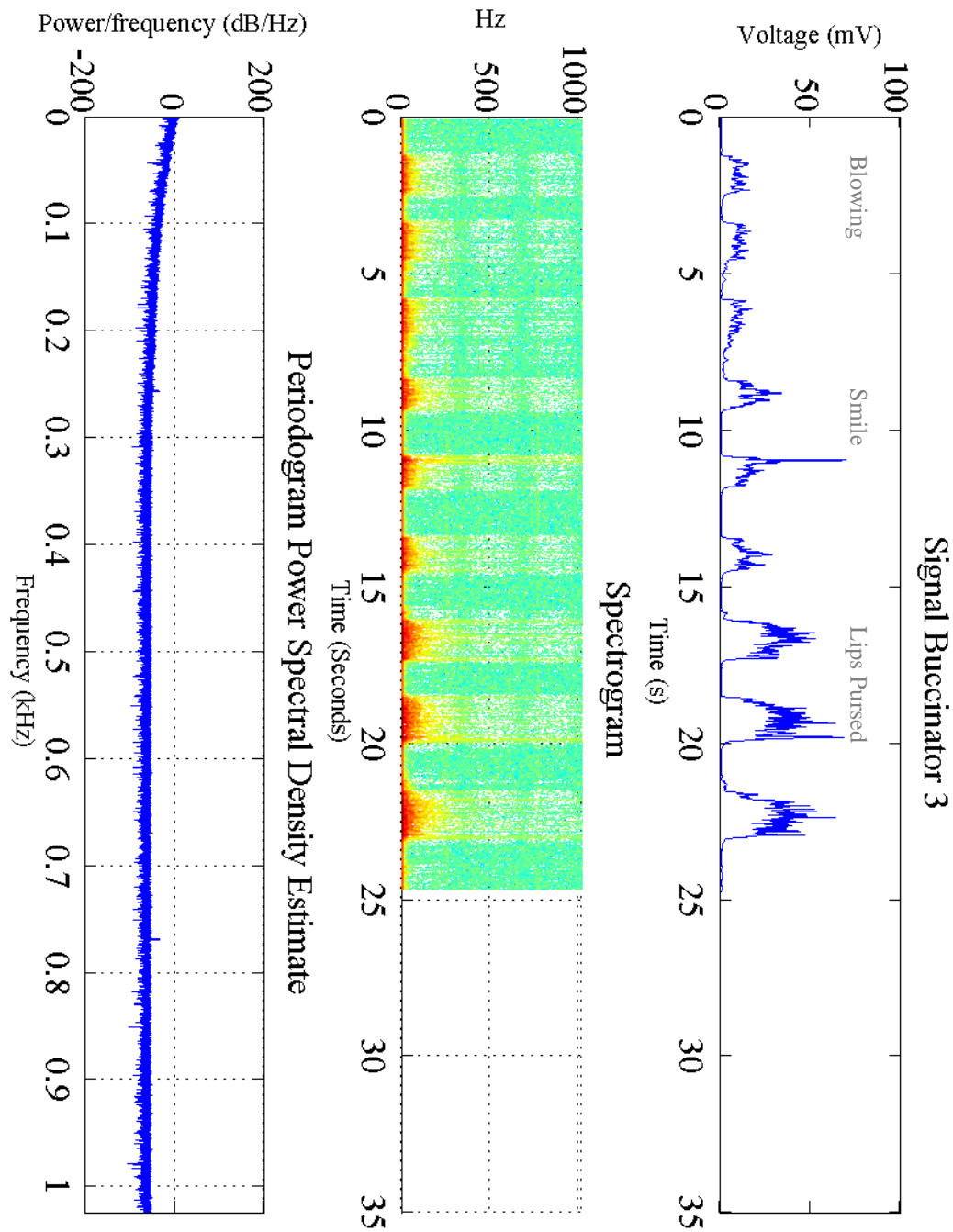

Figure 102: Buccinator EMG recordings showing: (A) blowing air through the lips in expressions of exasperation and self control. (B) Smiling. (C) Lips pursed in and expression of contemplative contraction.

5.4 EMG of the Depressor Anguli Oris

The Depressor Anguli Oris is used in frowning and showing disgust/scorn, EMG observation was performed via a placement detailed by Boxtel (Boxtel, 2010). The placement used two electrodes placed 10mm apart following the muscle fibres of the Depressor Anguli Oris. The placement was made from below the left corner of the mouth with an earth electrode at the bony prominence of the scalp just below the hair line, as shown in Figure 103.



Figure 103: Depressor Anguli Oris Electrode Placement.

The Depressor EMG testing involved: (A) Frowning, (B) Showing scorn, (D) Talking. The frowning was very minor in amplitude, but showed a frequency component that clearly identified it from background noise. Scorn was prominently displayed and distinct from general talking which was even higher in amplitude. A typical recording is shown in Figure 104.

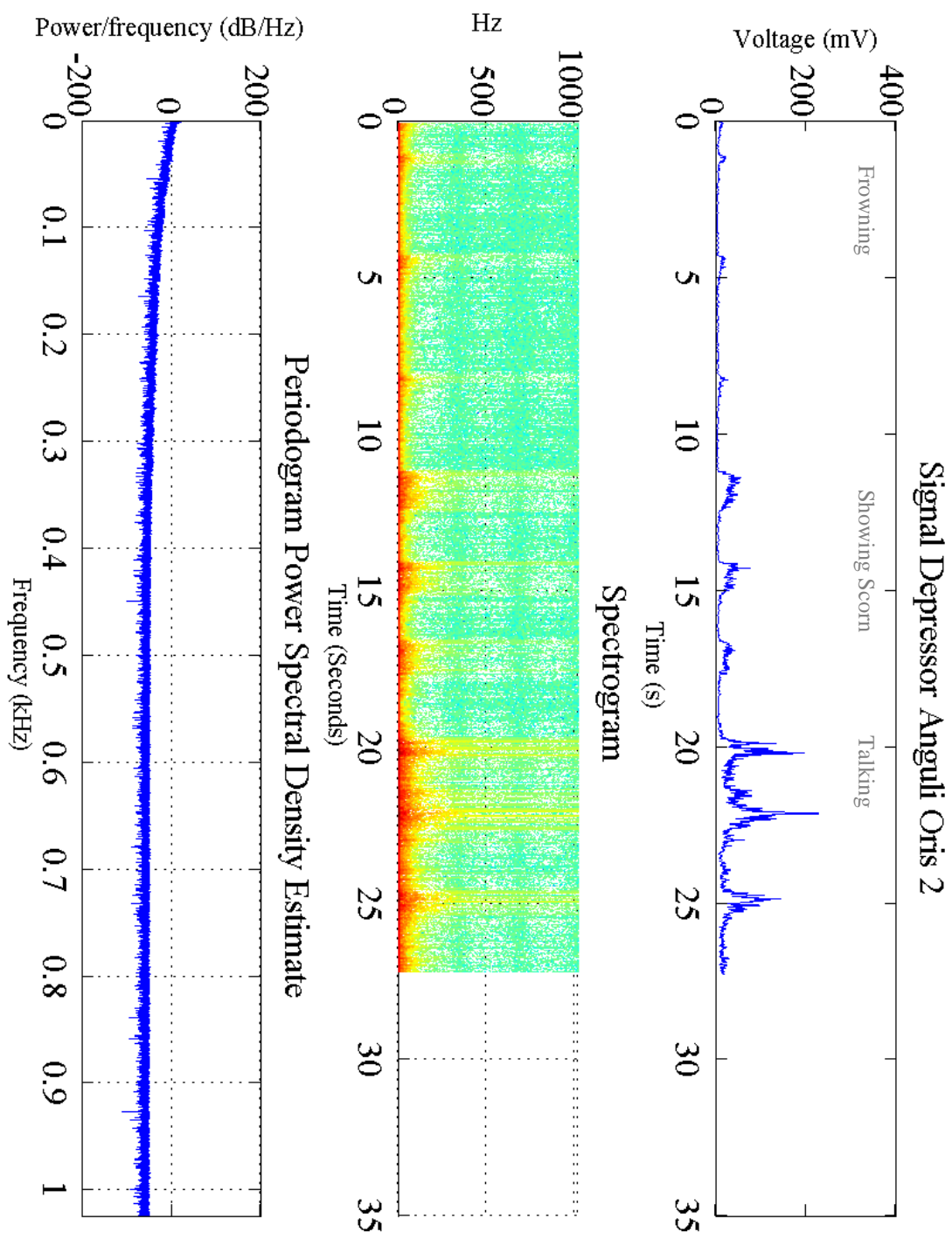

Figure 104: A typical Depressor Anguli Oris EMG recording showing: Frowning, (B) Showing scorn, (C) Talking.

5.5 EMG of the Mentalis

The Mentalis is used in grimacing and showing doubt and displeasure, EMG observation was performed via a placement detailed by Boxtel (Boxtel, 2010). The placement used two electrodes placed 10mm apart following the muscle fibres of the Mentalis. The placement was made on the left side of the chin and used an earth electrode at the bony prominence of the scalp just below the hair line, as shown in Figure 105. Actions known to produce artefacts include swallowing and talking.

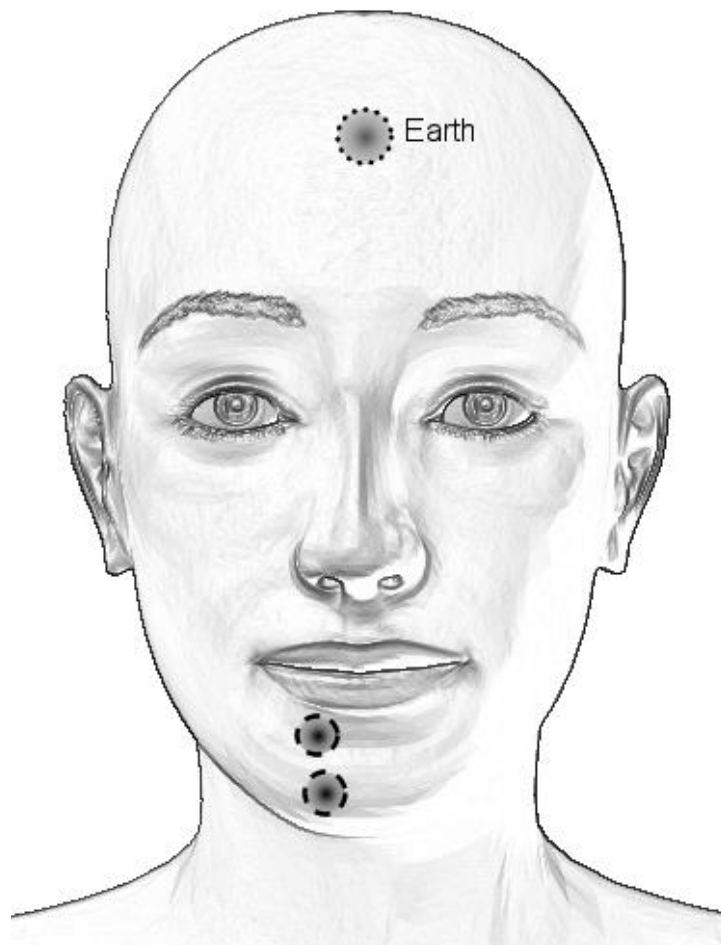

Figure 105: Mentalis Electrode Placement.

EMG testing of the Mentalis involved actions of grimacing , showing doubt, frowning and talking. Most actions produced a similar response with a sharp initial response. Talking was clearly identifiable due to its high amplitudes. A typical recording is shown in Figure 106.

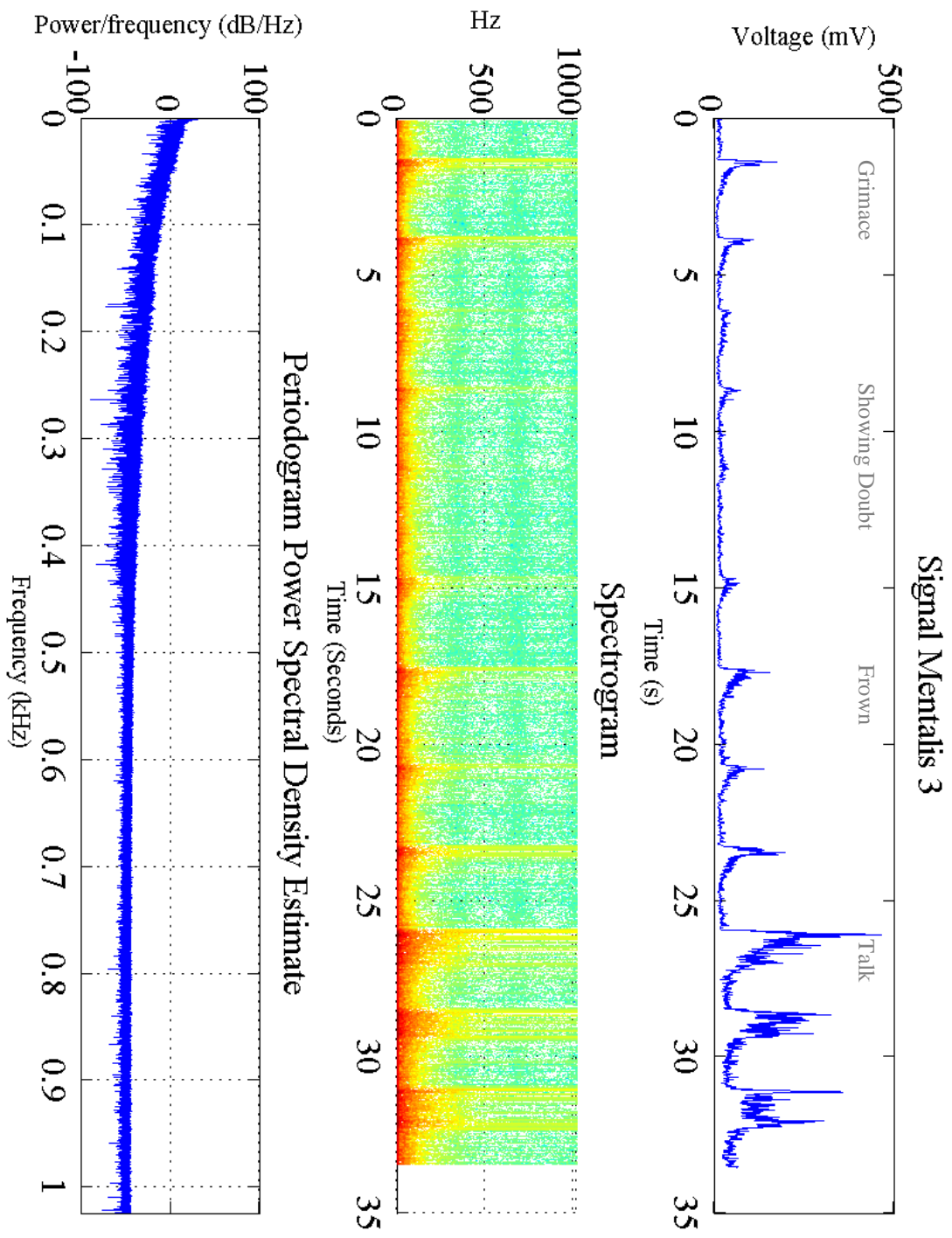

Figure 106: EMG testing of the Mentalis showing typical results for actions of grimacing, showing doubt, frowning and talking.

5.6 EMG of the Orbicularis Oculi

The Orbicularis Oculi is used in expressions of joy, sadness, concentration and attention, EMG observation was performed via a placement detailed by Cram et al., (1998) and Boxtel (2010). The placement used two electrodes placed 10mm-20mm apart along the Zygomatic bone. The placement was made with one electrode just below the eyelid in-line with the iris of the eye. The second electrode was placed laterally to the eye and the first electrode. The earth electrode was positioned at the bony prominence of the scalp just below the hair line, as shown in Figure 107.

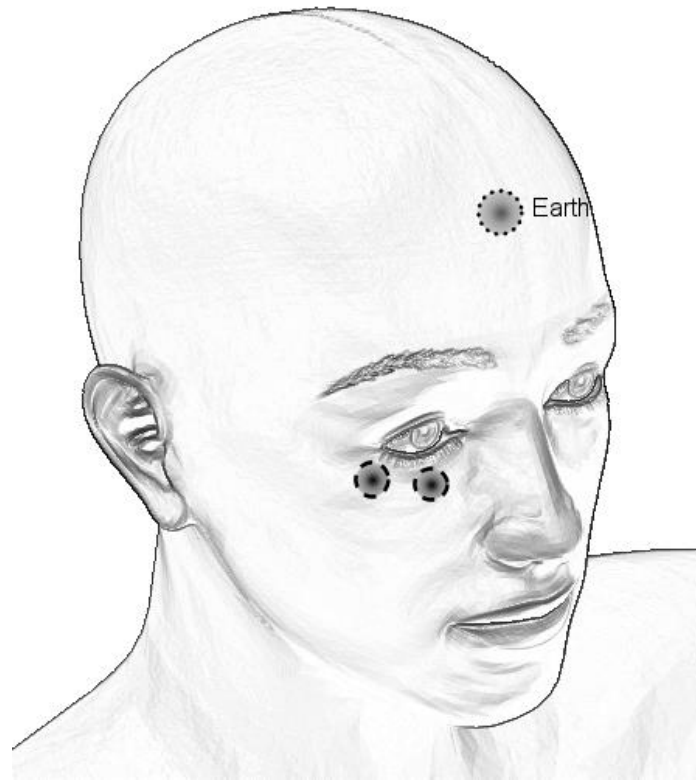

Figure 107: Orbicularis Oculi Electrode Placement.

EMG testing of the Orbicularis Oculi involved the actions of blinking, squinting and smiling. All three actions are readily distinguished making the muscle an excellent candidate for examination. The presence of blinking in the EMG recording allows the calculation of the inter-blink interval which may be a useful statistic. Its promising signal qualities however are offset in experimental conditions by the very uncomfortable nature of electrode placement very near to the eye and within the field of vision. A typical recording is shown in Figure 108.

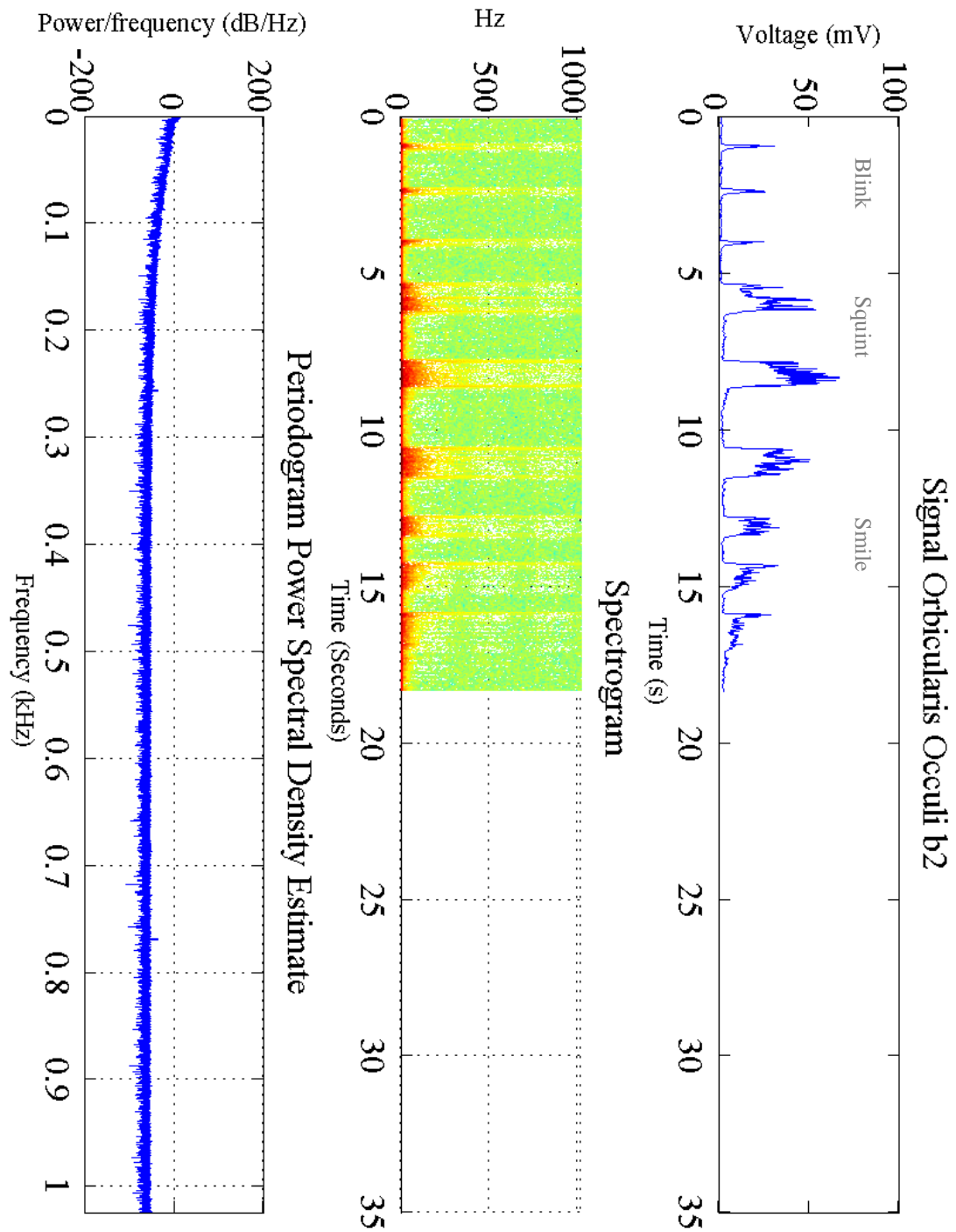

Figure 108: Typical EMG recordings for the Orbicularis Oculi showing the actions of blinking, squinting and smiling.

5.7 EMG of the Frontalis

The Frontalis raises the eyebrows and is thus connected with many emotional displays such as admiration, astonishment, confusion, fear and surprise. EMG observation was performed via the (lateral) placement detailed by Cram et al., (1998) and Boxtel (2010). The placement used two electrodes placed 10mm apart following the muscle fibres of the Frontalis. The placement was made with both electrodes positioned vertically above the iris of the eye. The earth electrode was placed at the bony prominence of the scalp just below the hair line, as shown in Figure 109. Actions known to produce artefacts include swallowing and non-verbal communication.

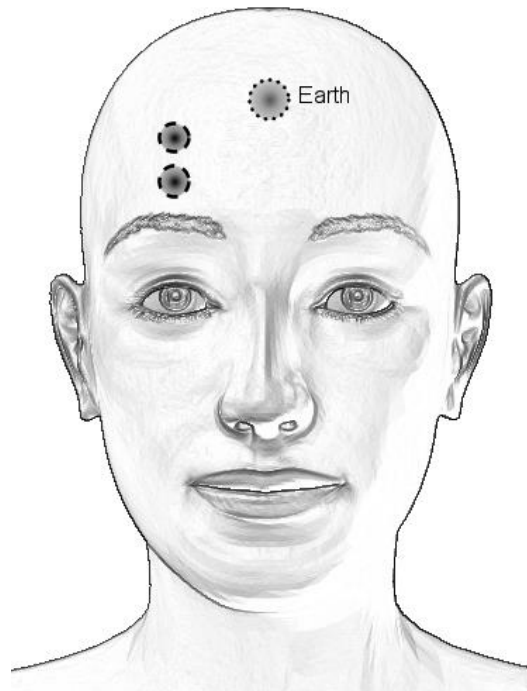

Figure 109: Frontalis Electrode Placement.

EMG testing of the Frontalis involved posed expressions of anger, surprise and sadness. The resulting features are easily distinguished, but the posed sad face is more evident in the spectral domain. A typical recording is shown in Figure 110.

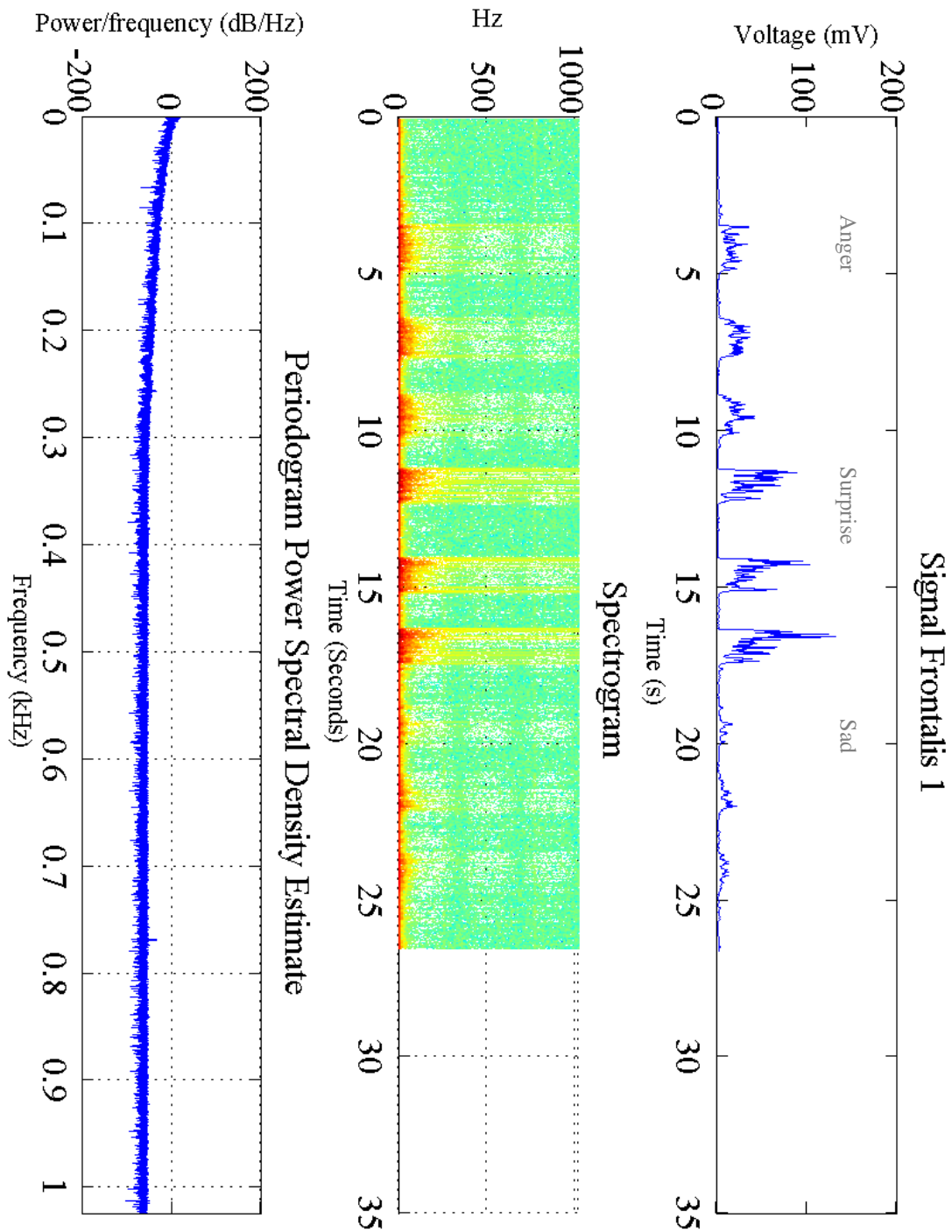

Figure 110: Typical EMG recordings for the Frontalis showing posed expressions of anger, surprise and sadness.

5.8 EMG of the Corrugator Supercilii

The Corrugator Supercilii pulls the eyebrows inward and downward and is thus connected with many negative emotional displays such as desperation, displeasure, impatience, pain, suffering, rage, unhappiness and effort. EMG observation was performed via the placement detailed by Cram et al., (1998) and Boxtel (2010). The placement used two electrodes placed 10mm apart following the muscle fibres of the Corrugator Supercilii. The placement was made with both electrodes positioned obliquely following the brow. The earth electrode was placed at the bony prominence of the scalp just below the hair line, as shown in Figure 111. Actions known to produce artefacts include blinking and non-verbal communication.

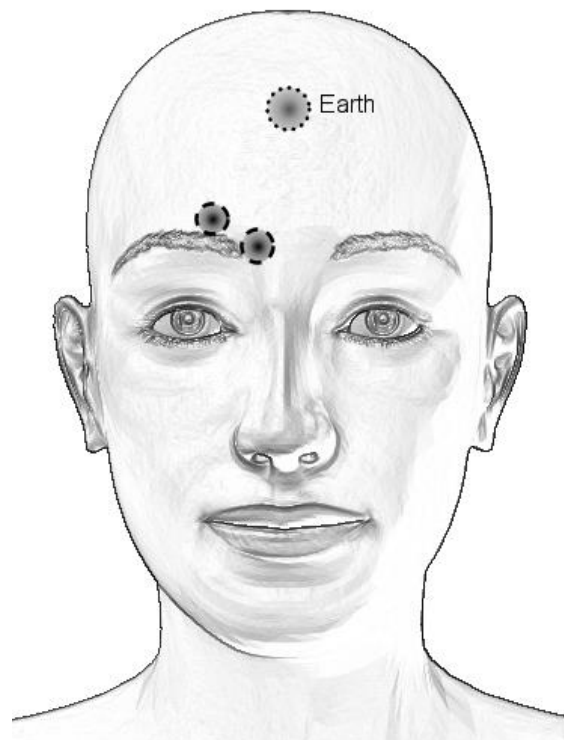

Figure 111: Corrugator Supercilii Electrode Placement

The EMG testing for the Corrugator Supercilii involved expressions of frowning, pain, desperation and effort. The frowning created a low amplitude feature, while pain created a similar feature, but with a single high amplitude peak. Desperation produced a very high amplitude response with several spikes. Sadness was similar, but lower in amplitude and with fewer spikes. A typical recording is shown in Figure 112.

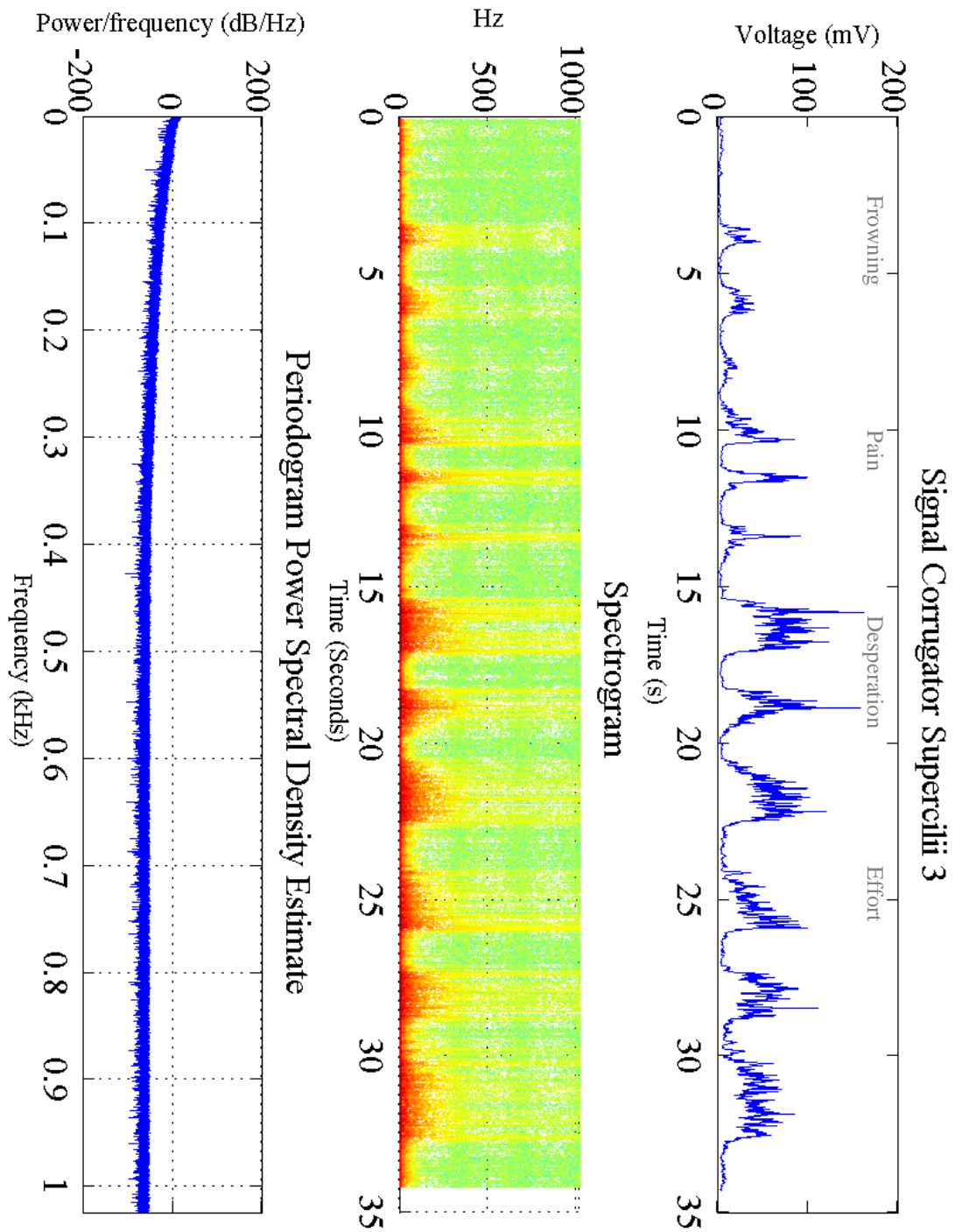
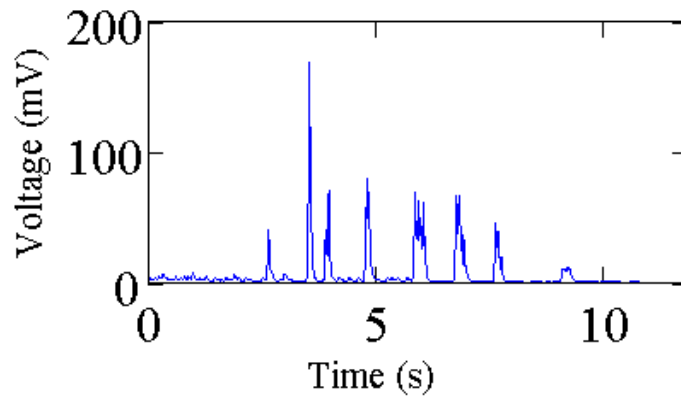

Figure 112: Typical EMG recordings for the Corrugator Supercilii showing expressions of frowning, pain, desperation and effort.

Signal Corrugator Supercilii blinks



Spectrogram

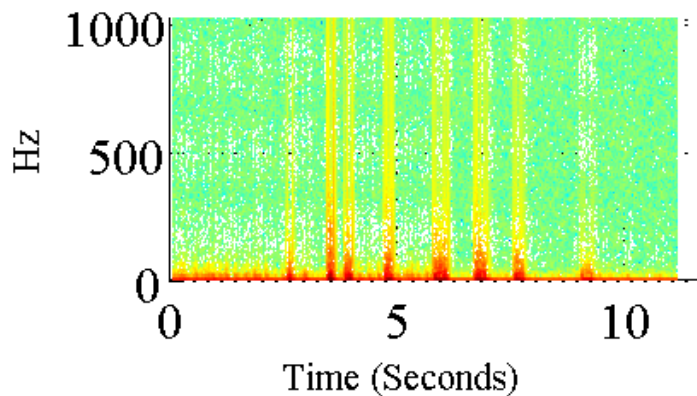

Figure 113: EMG of the Corrugator Supercilii showing blink artefact.

In addition to providing distinct features for different facial expressions, the EMG recordings for the Corrugator Supercilii were also (occasionally) able to detect blinks. This would be very useful information except it was not always repeatable. Some blinks did not detect and for some participants of the trials no effect was observed at all. The blink detection appeared to depend heavily on the individual involved and the quality of the EMG electrode placement. A successful recording is given in Figure 113.

5.9 EMG of the Suprahyoid Placement

The Suprahyoid Placement (Cram et al., 1998) is used as a general recording of the muscles that move the mouth, tongue and elevate the larynx. It receives EMG feedback from the Platysma and Sternomastoid (the neck muscle that flexes and rotates the head. Electrode placement is shown in Figure 114, it uses an earth electrode at the bony prominence of the scalp just below the hair line and two electrodes located under the chin running along the midline (Cram et al., 1998).. Electrodes were placed 20mm apart on the area that forms in a mass when the participant swallowed.

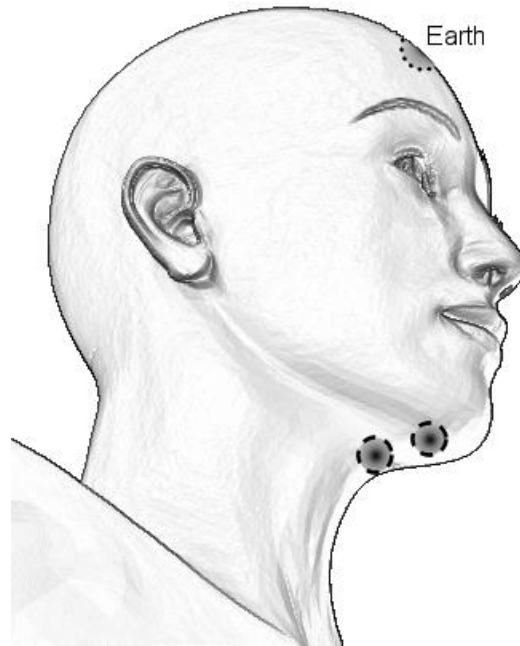

Figure 114: Suprahyoid Placement.

A set of typical EMG recordings for the Suprahyoid Placement is given as a series of graphs from Figure 115 through to Figure 121. While interesting, it is often not possible to distinguish the features recorded. For instance a frown appears very similar to laughter. An interesting result was the detection of suppressed laughter, shown in Figure 118. This occurred when the participant was “keeping a straight face” and trying not to laugh.

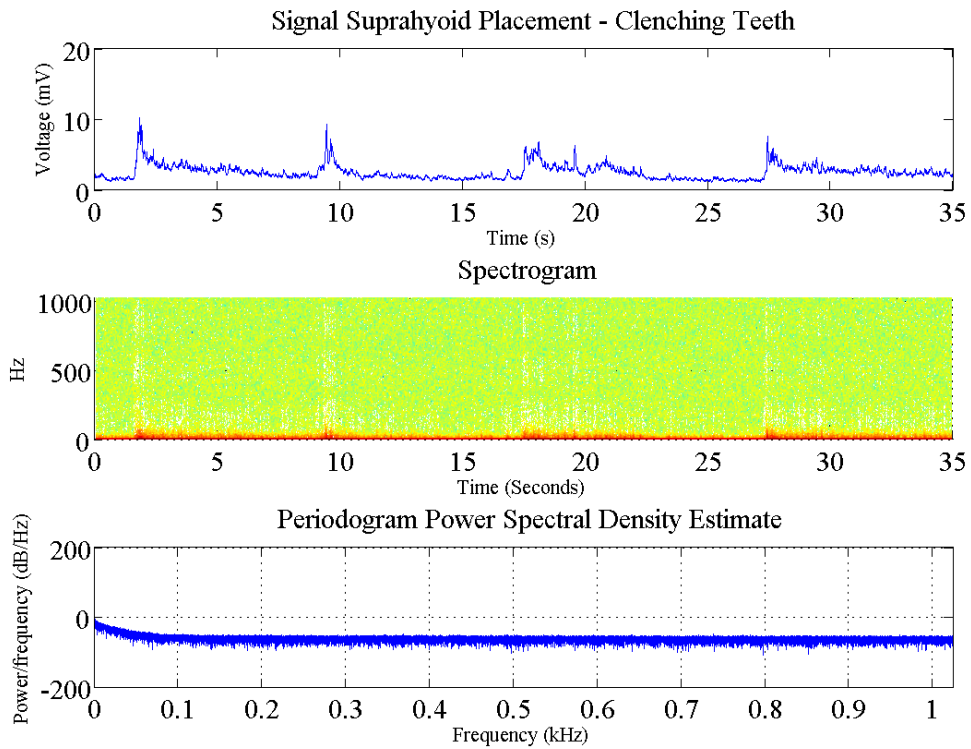

Figure 115: Typical EMG recordings for the Suprahyoid Placement. Participant Clenched their teeth four times.

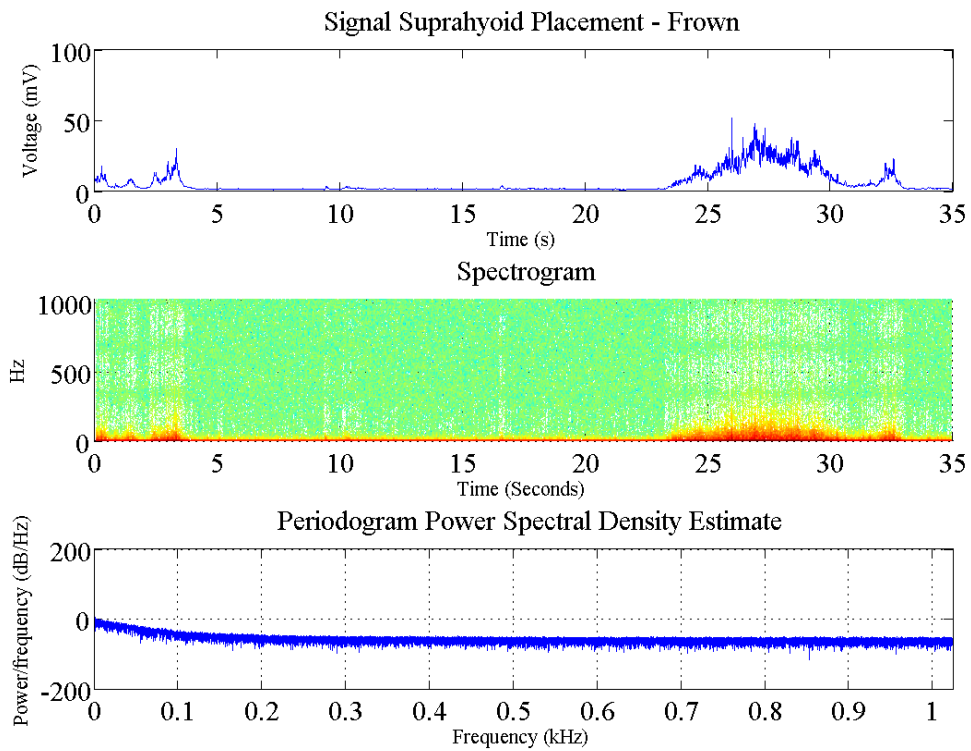

Figure 116: Typical EMG recordings for the Suprahyoid Placement. Two frowns are shown. Note: The first frown was less intense.

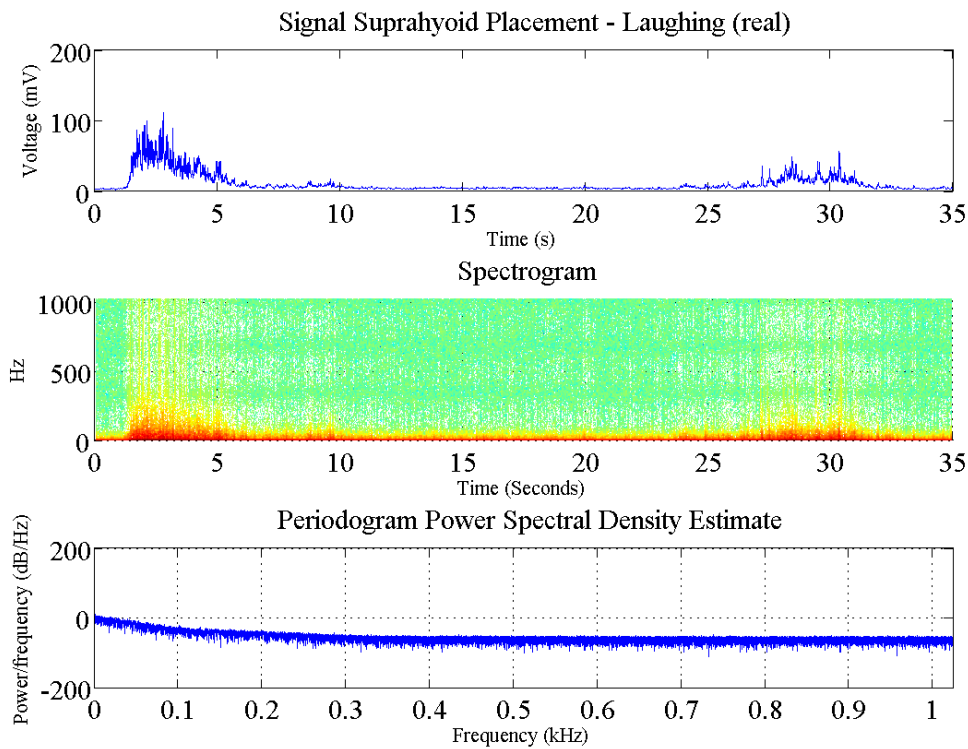

Figure 117: Typical EMG recordings for the Suprahyoid Placement. The recording is of genuine laughter that was invoked by the telling of a joke.

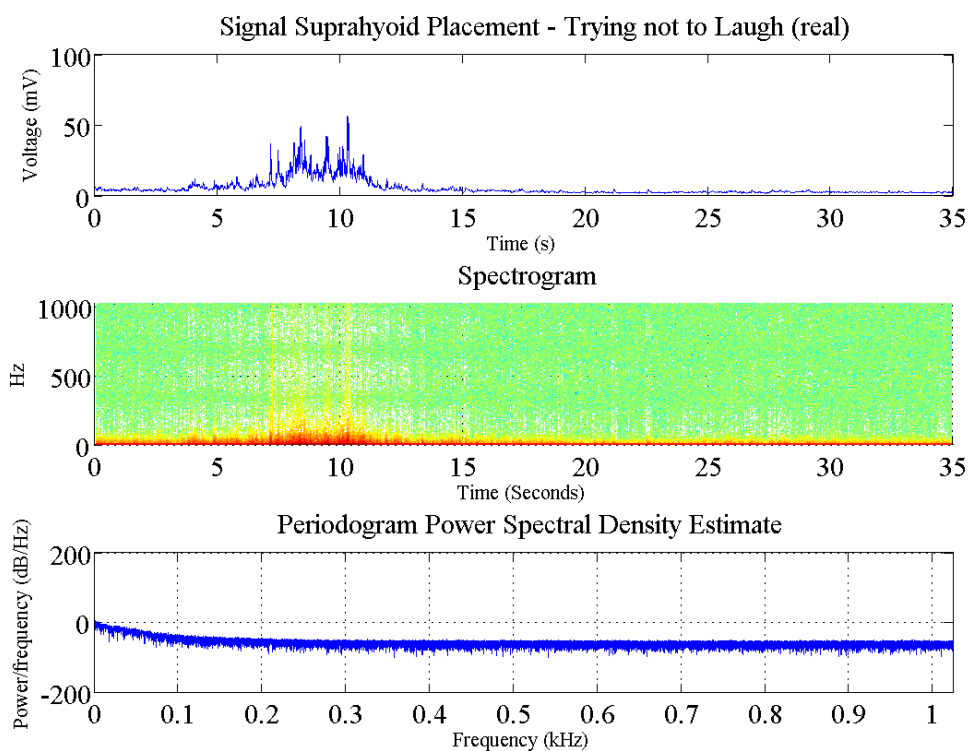

Figure 118: Typical EMG recordings for the Suprahyoid Placement. The participant was instructed to please stop laughing at a previous joke. The face returns to a visibly neutral position, but the suppressed laughter was still detected.

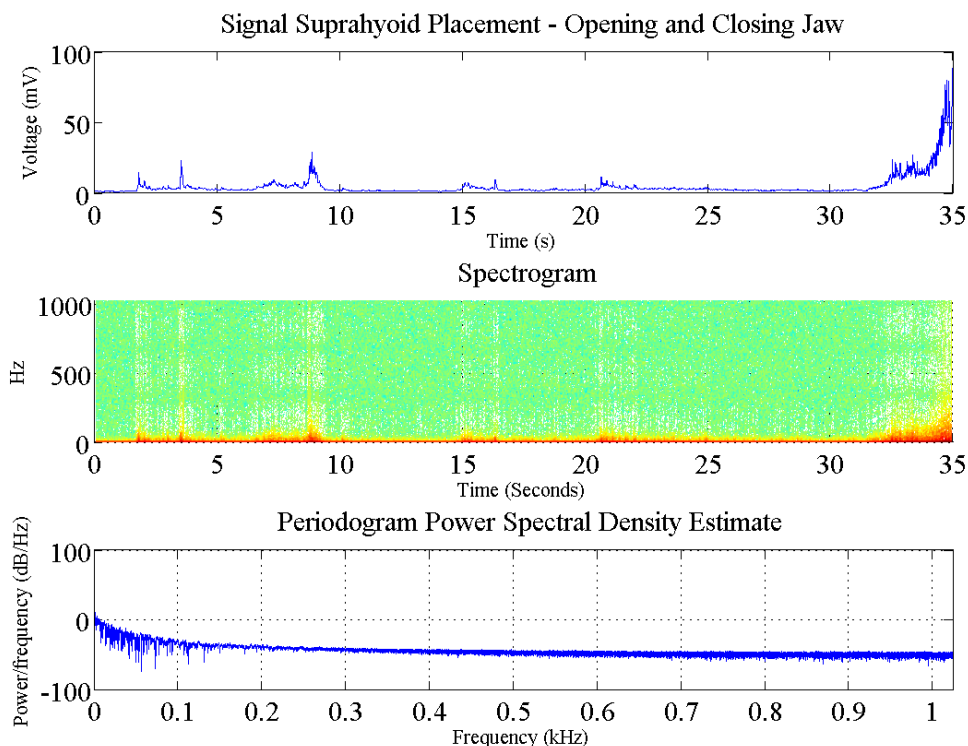

Figure 119: Typical EMG recordings for the Suprahyoid Placement. Jaw was opened and closed several times. The feature after the 30 second mark is unrelated.

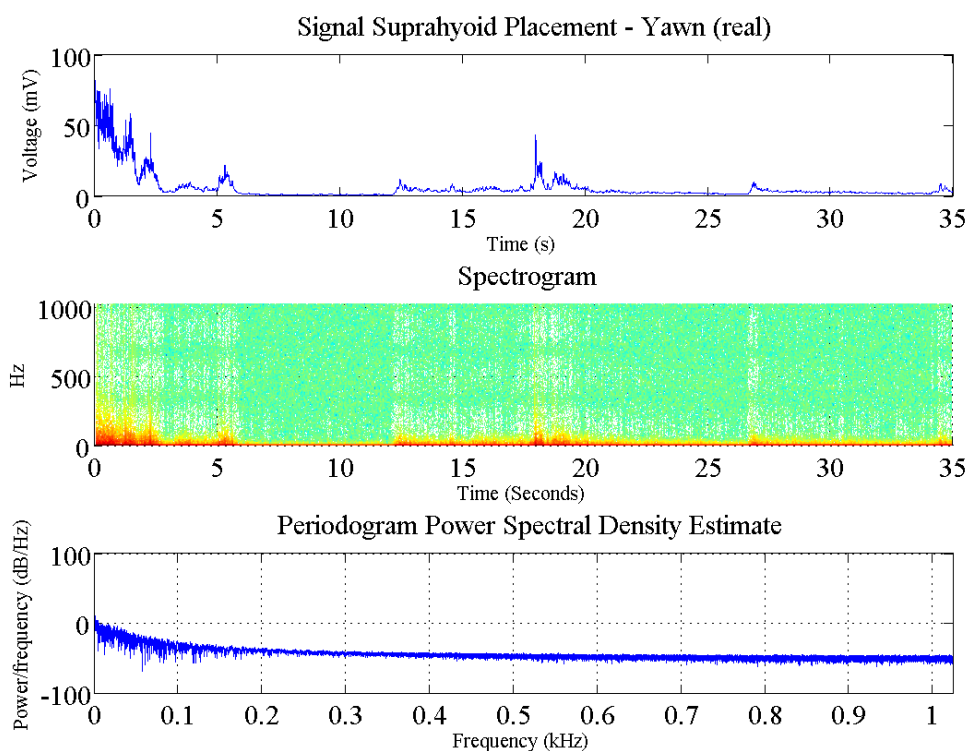

Figure 120: Typical EMG recordings for the Suprahyoid Placement. The participant spontaneously yawned.

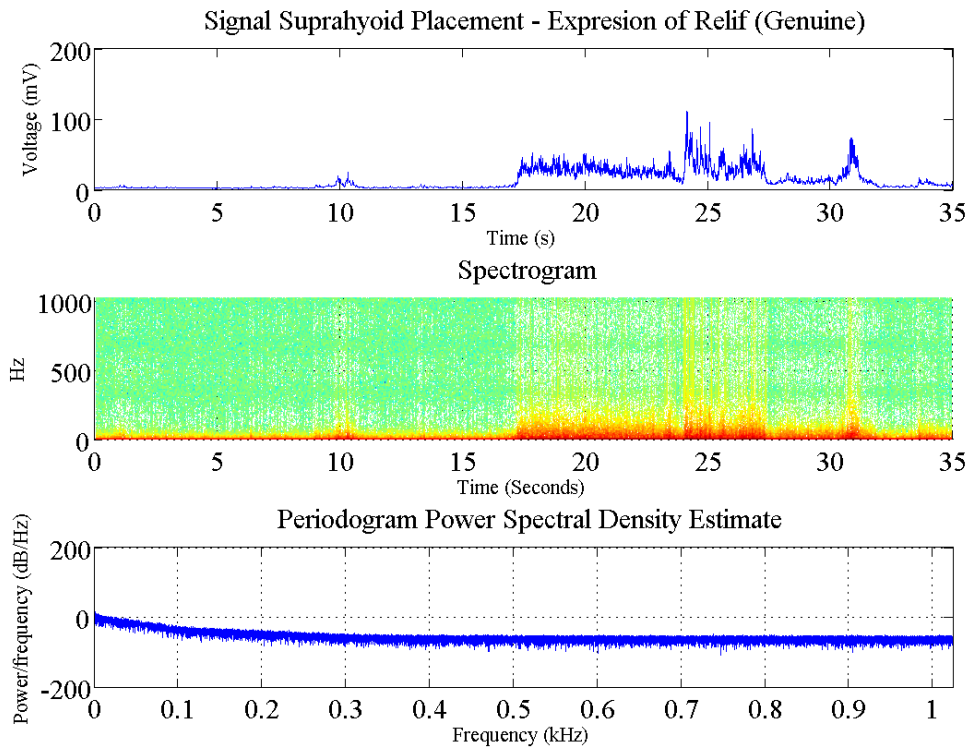

Figure 121: Typical EMG recordings for the Suprahyoid Placement. (Displaying a (genuine) sigh of relief after a long recording session).

5.10 EMG of the Temporal Suprahyoid Placement

The Temporal Suprahyoid Placement (C. Schneider & Wilson, 1985) is used as a general recording of the perennial facial muscles (Cram et al., 1998). It receives EMG feedback from the Frontalis, Corrugator Supercilii, Anterior Temporalis, Orbicularis Oculi, Orbicularis Oris, Masseter, Buccinator Mentalis Depressor Anguli Oris, Throat and Tongue. Actions known to produce artefacts include swallowing and talking. Electrode placement is shown in Figure 122, it uses an earth electrode at the bony prominence of the jaw line and two regular electrodes. One electrode is located 30mm above the Zygomatic arch lateral to the brow and the other is placed in the muscle that can be felt on the anterior lateral border of the chin when the mouth is opened (Cram et al., 1998).

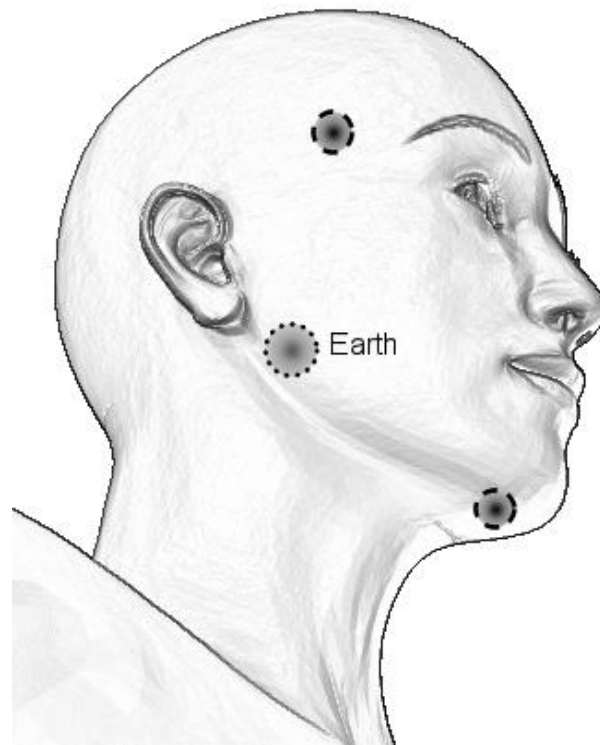

Figure 122: Temporal Suprahyoid Placement.

Testing of the Temporal Suprahyoid Placement was conducted using smiling, frowning, raising eyebrows, showing surprise. Raising the eyebrows and opening and closing the jaw. It was generally not possible to identify any actions by the collected EMG signal. Though frowning did use a broader range of the spectrum than smiling. Typical results are shown from Figure 123 to Figure 127.

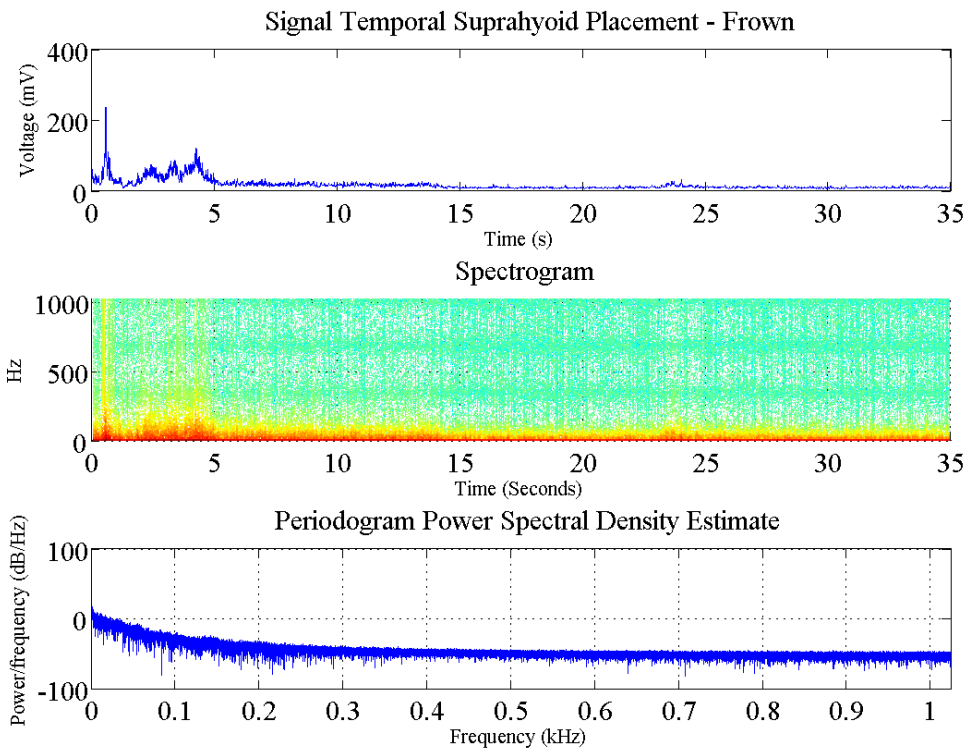

Figure 123: Typical EMG recordings for the Temporal Suprahyoid Placement showing the features created by frowning.

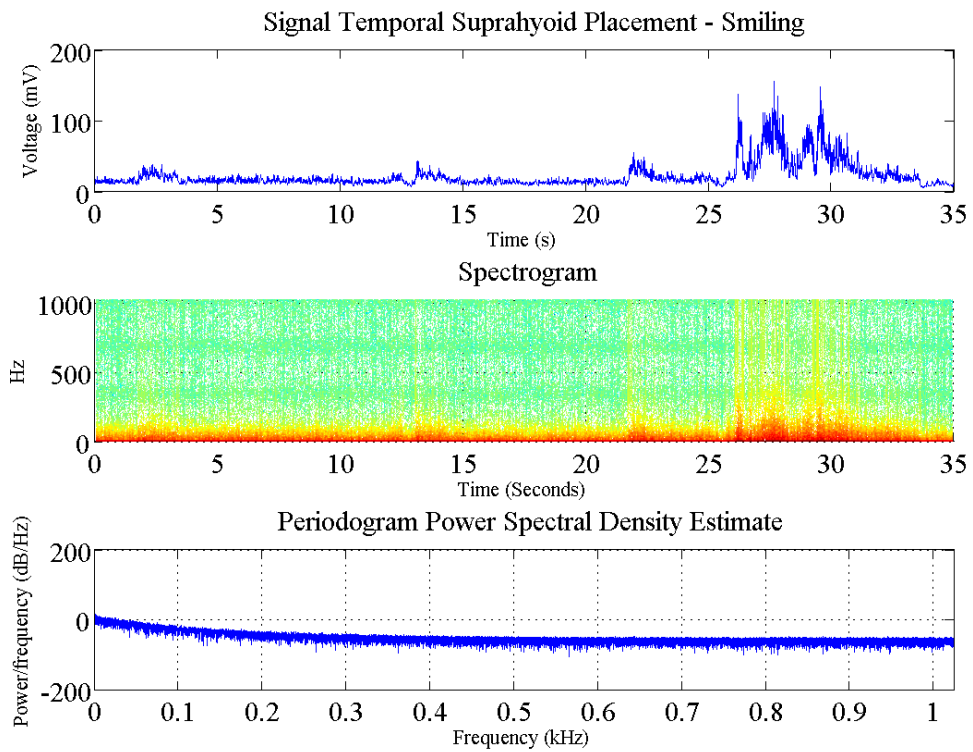

Figure 124: Typical EMG recordings for the Temporal Suprahyoid Placement showing smiling.

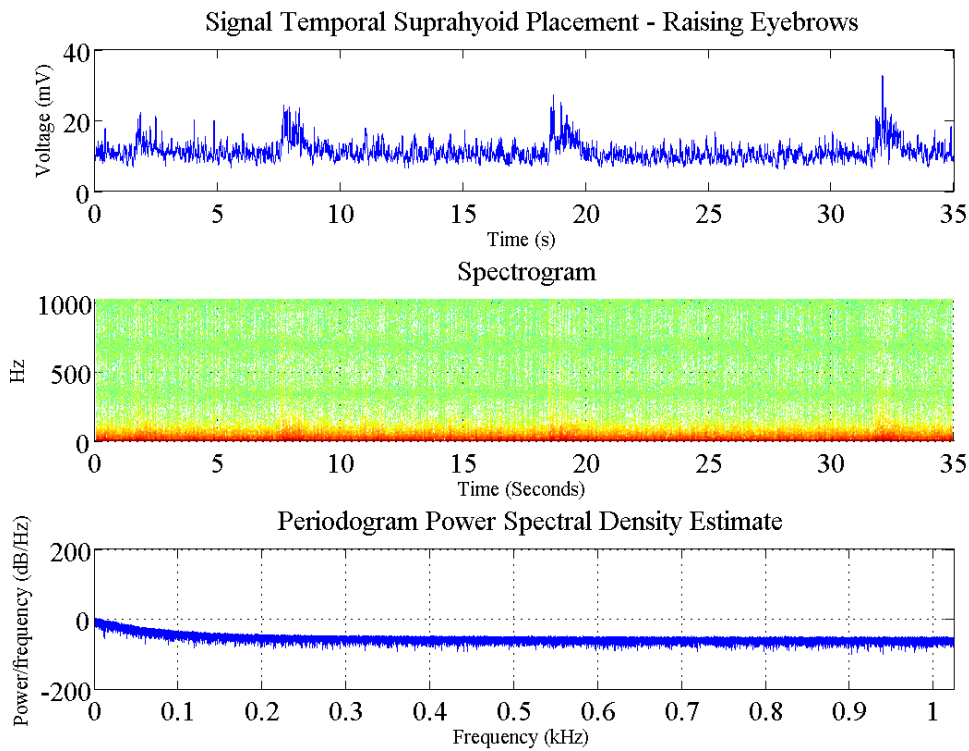

Figure 125: Typical EMG recordings for the Temporal Suprahyoid Placement showing four raises of the eyebrows.

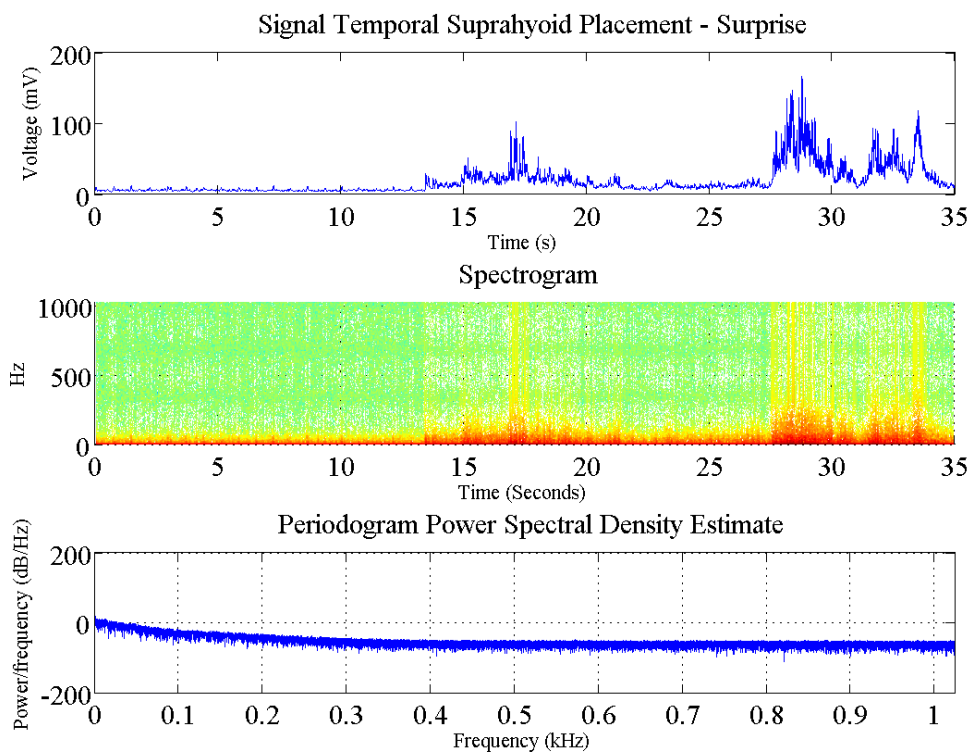

Figure 126: Typical EMG recordings for the Temporal Suprahyoid Placement showing posed surprise.

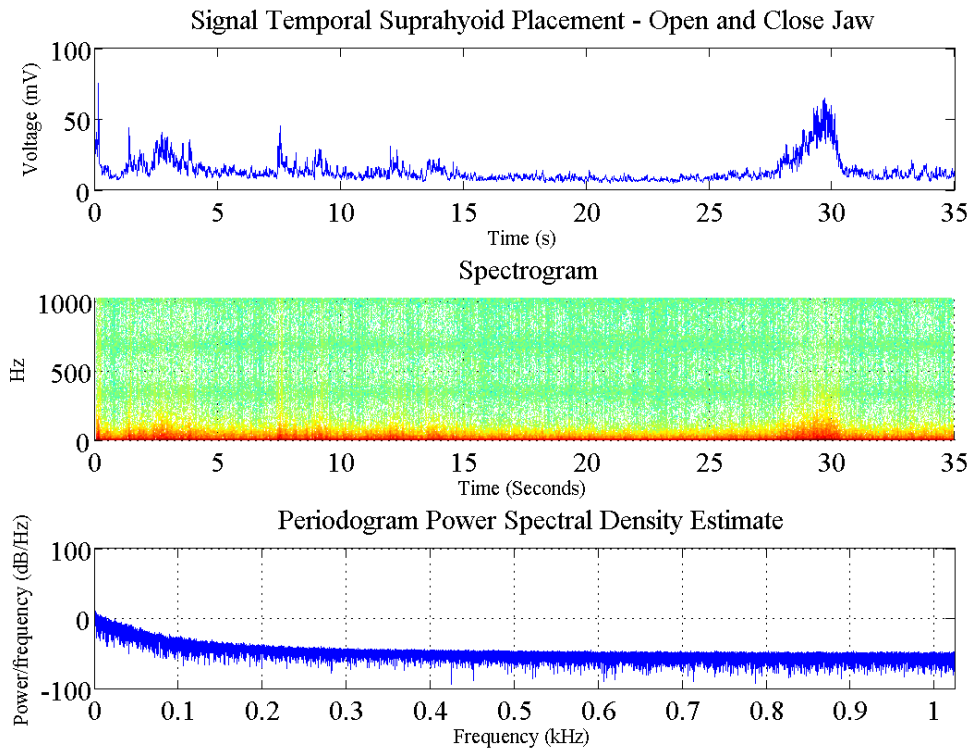

Figure 127: Typical EMG recordings for the Temporal Suprahyoid Placement showing the features created by opening and closing the jaw. The last feature is the jaw closing.

5.11 EMG of the Temporal Masseter (Wide) Placement

The Masseter (Wide) Placement (Cram et al., 1998) is used as a general recording of the muscles of the jaw. It receives EMG feedback from the Temporalis, Masseter, Frontalis, Corrugator Supercilii, Zygomaticus Major, Orbicularis Oculi Orbicularis Oris and Buccinator. It is used in diagnosing facial pain disorders. Actions known to produce artefacts include swallowing and talking. Electrode placement is shown in Figure 128, it uses an earth electrode at the bony prominence of the scalp just below the hair line and two recording electrodes (Cram et al., 1998). One electrode is located 30mm above the Zygomatic arch lateral to the brow and the other is placed on the Masseter muscle lateral to the mouth.

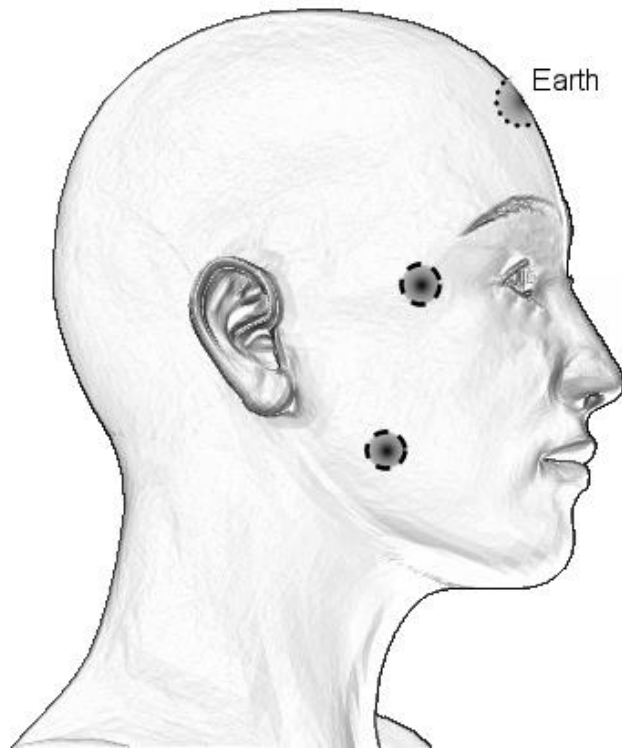

Figure 128: Masseter (Wide) Placement.

Testing of the Masseter (Wide) Placement was conducted using clenching of the jaw, extending the jaw, laughing (genuine) and yawning (real). It was generally not possible to identify any actions by the collected EMG signal. All actions were uniformly 100mV in amplitude. Clenching of the jaw had a uniquely sharp onset and termination and laughing produced a longer more sustained signal.

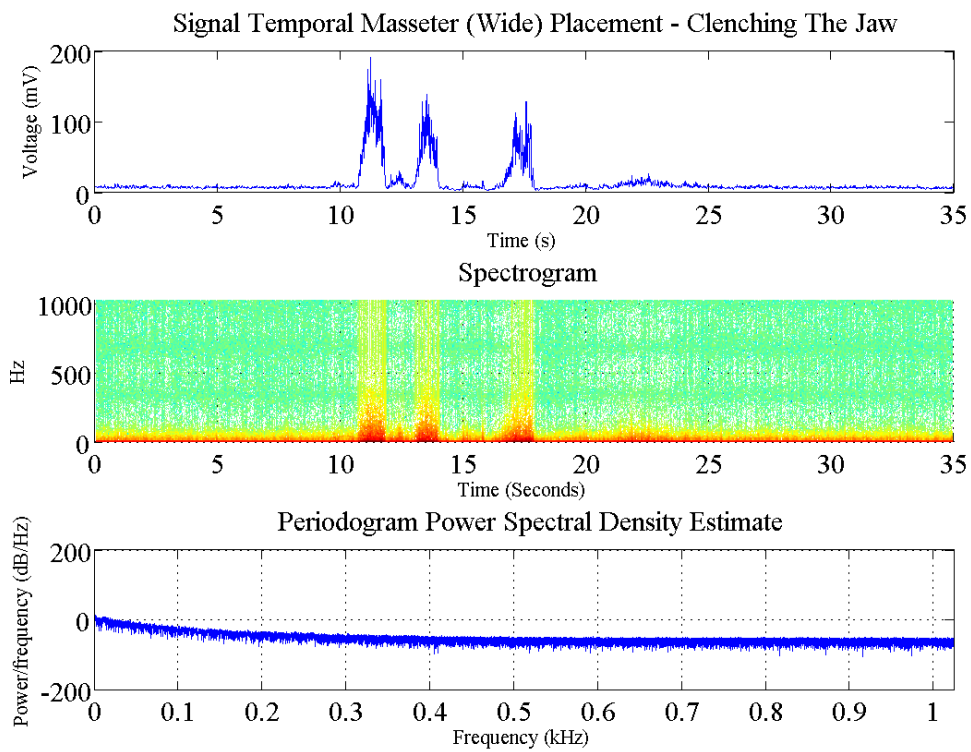

Figure 129: Typical EMG recordings for the Masseter (Wide) Placement showing clenching of the Jaw.

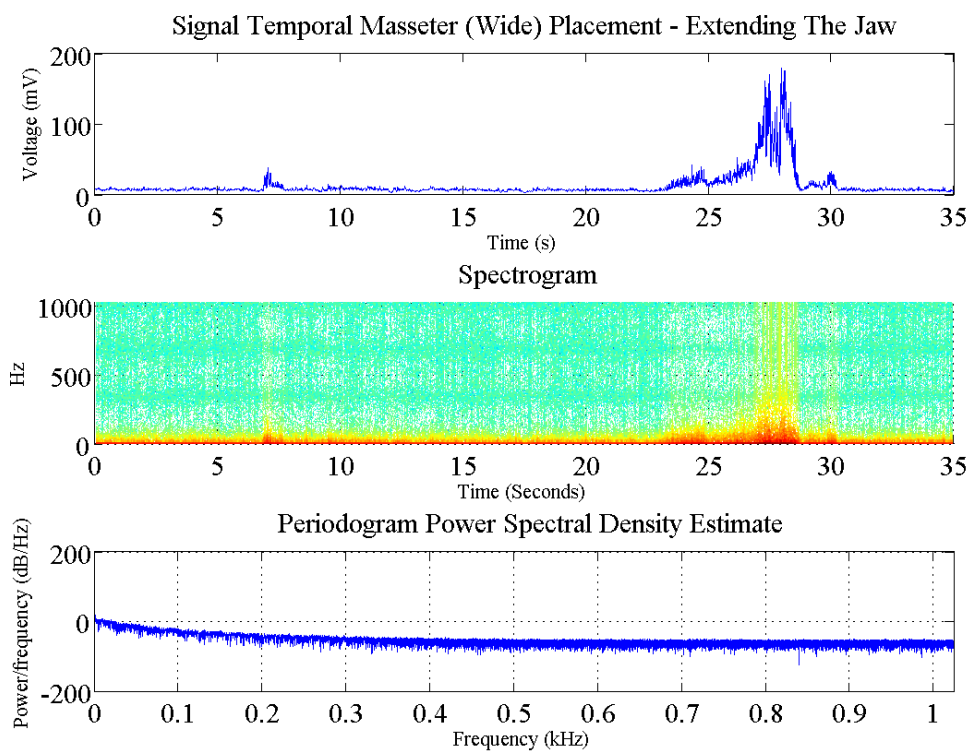

Figure 130: Typical EMG recordings for the Masseter (Wide) Placement showing a single extension of the jaw.

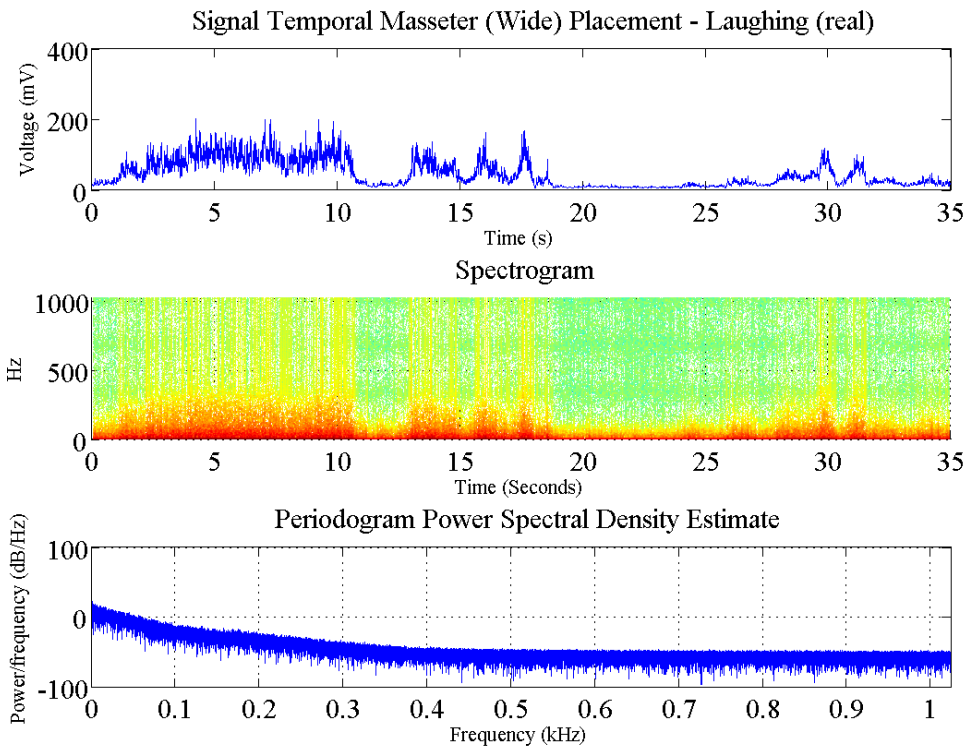

Figure 131: Typical EMG recordings for the Masseter (Wide) Placement showing genuine laughter in response to a joke.

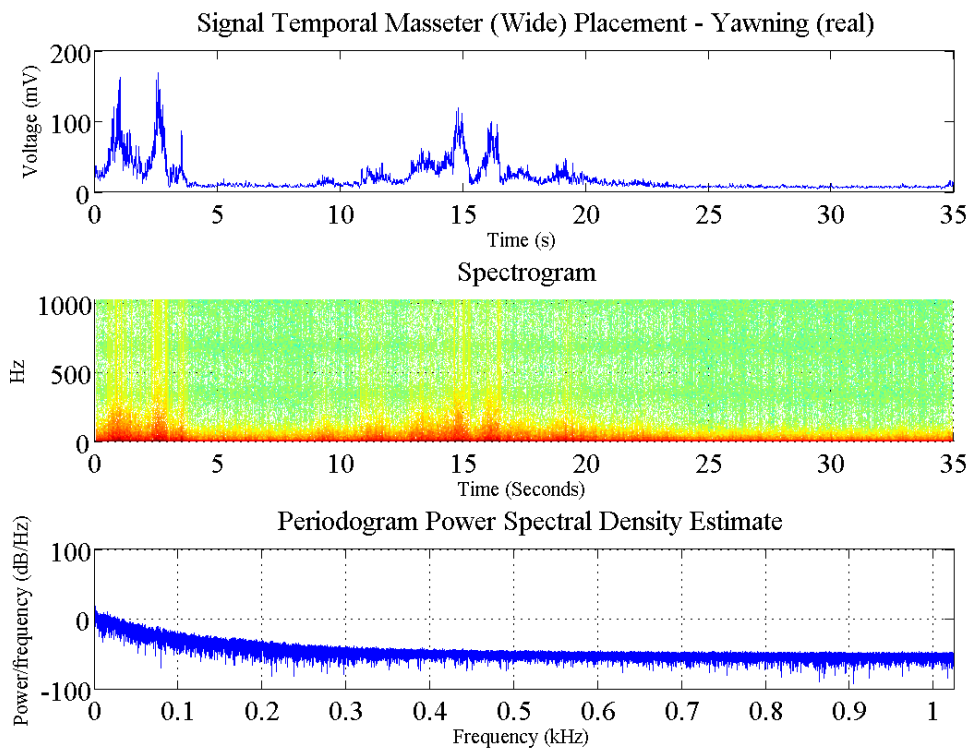

Figure 132: Typical EMG recordings for the Masseter (Wide) Placement, showing a genuine yawn.

5.12 EMG of the Frontal (Wide) Placement

The Frontal (Wide) Placement (Cram et al., 1998) is used as a general recording of the facial muscles of the eyes. It receives EMG feedback from the Frontalis, Temporals, Corrugator Supercilii, Nasalis Transversa and the Masseter (muscle used to chew). It is used in psychophysiology to profile stress responses. Actions known to produce artefacts include swallowing and talking. Electrode placement is shown in Figure 133, it uses an earth electrode at the bony prominence of the scalp just below the hair line and two active electrodes located 6mm above the eyebrows directly above the pupils of the eyes (Cram et al., 1998).

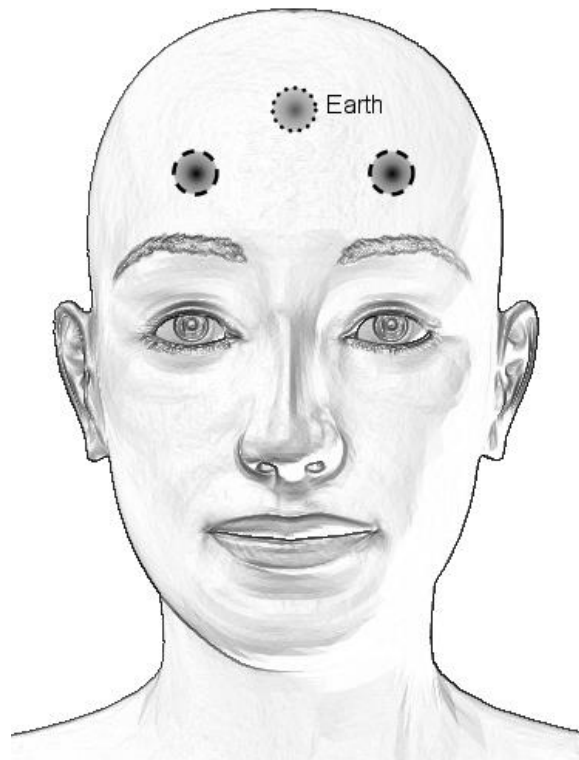

Figure 133: Frontal (Wide) Electrode Placement.

Trailing the Frontal (Wide) Placement involved frowning, clenching the jaw, raising the eyebrows and swallowing. We found that frowns were not prominently displayed in all cases. The raising of the eyebrows however was a short feature that gave a very large reading (over 300mV).

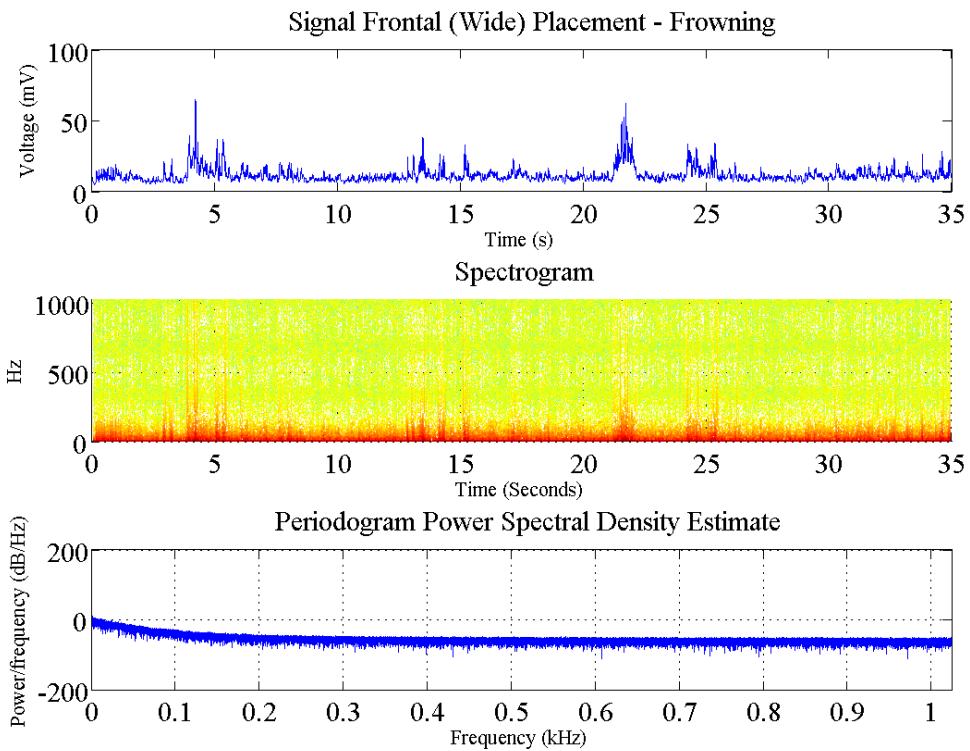

Figure 134: Typical EMG recordings for the Frontal (Wide) Placement showing the action of frowning.

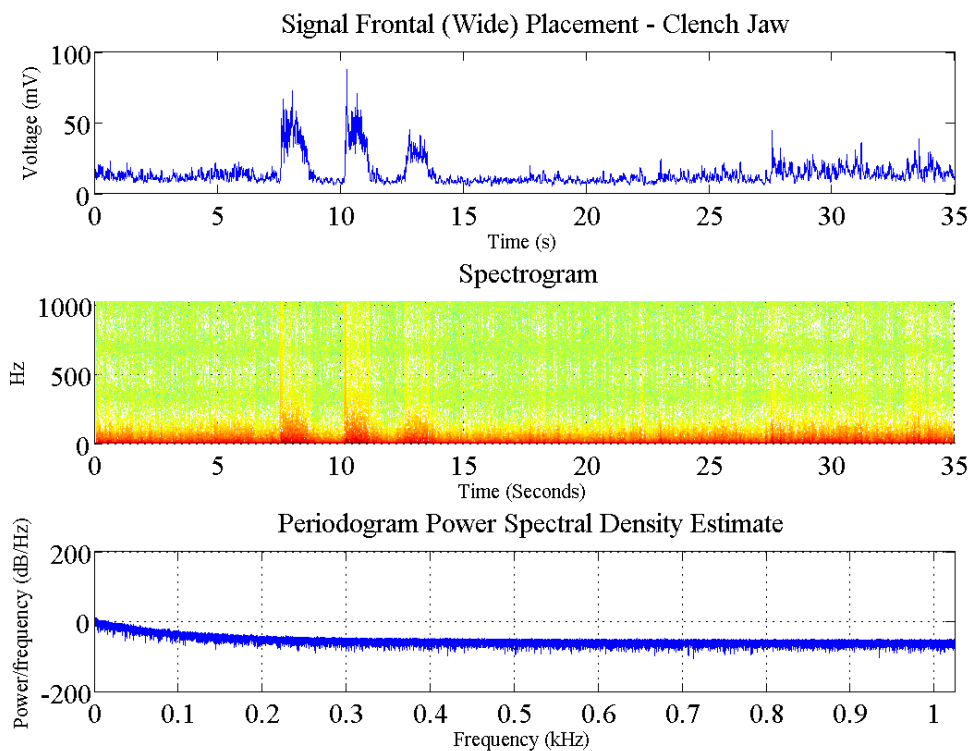

Figure 135: Typical EMG recordings for the Frontal (Wide) Placement showing the action of clenching the jaw.

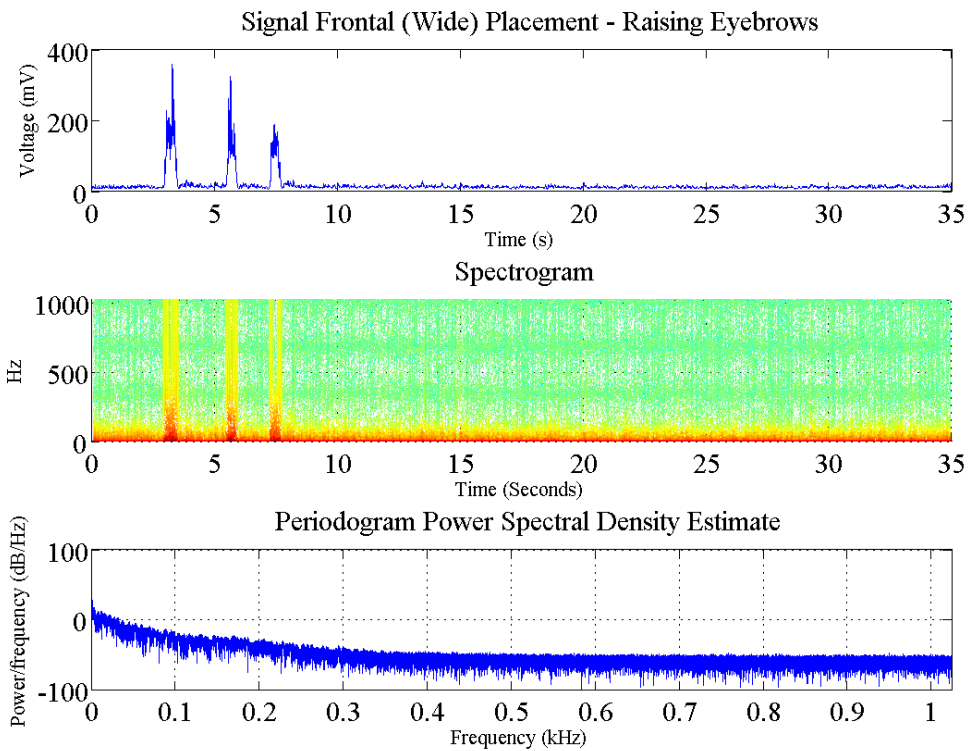

Figure 136: Typical EMG recordings for the Frontal (Wide) Placement showing the action raising the eyebrows three times.

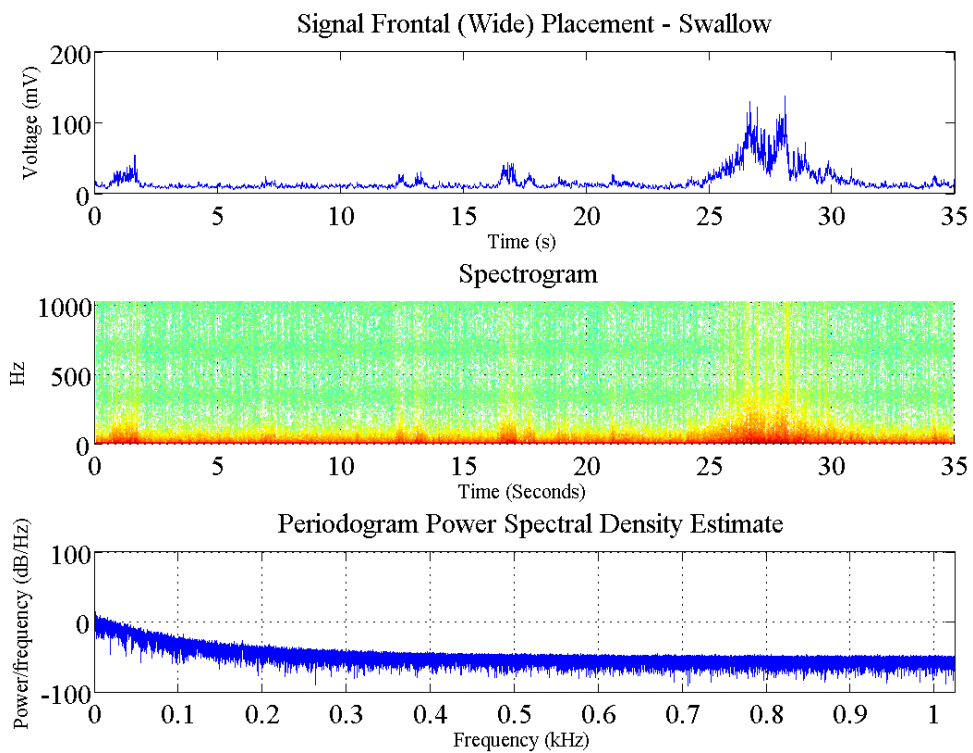

Figure 137: Typical EMG recordings for the Frontal (Wide) Placement showing the action of swallowing.

5.13 Conclusion

In this section we discussed our trial experiments with using EMG to examine different muscles. We observed that, of the muscles examined, the Frontalis, Zygomaticus Major, Mentalis, Orbicularis Oculi and Corrugator Supercilii showed distinct and usable responses to a variety of facial expressions. We also observed that artefacts, created by talking for example, could be readily identified so as to be removed from the signal. These muscles may be very useful in attempting to detect specific emotional responses.

We also investigated a series of multiple muscle placements; namely the Suprahyoid Placement, Temporal Suprahyoid Placement, Masseter (Wide) Placement and the Frontal (Wide) Placement. These placements generally originated in clinical (medical) use, but when applied to emotional data they managed to show a very wide array of responses to many facial actions. However the responses were in many cases difficult to distinguish from each other. Such placements may be very useful as “Emotional Barometers” which give an indication of how much emotional activity is present, without revealing what emotion was responsible for the activity.

This preliminary study into facial EMG response provided a replication of results achieved by a broad spectrum of previous researchers. Knowing that we can see the effects observed by others allows our selection of muscles for EMG investigation to be based on practical experience as well as previous research. The visual presentation of time and frequency data will also assist later with choosing appropriate metrics to calculate and features to extract.

6.0 Experimental Design

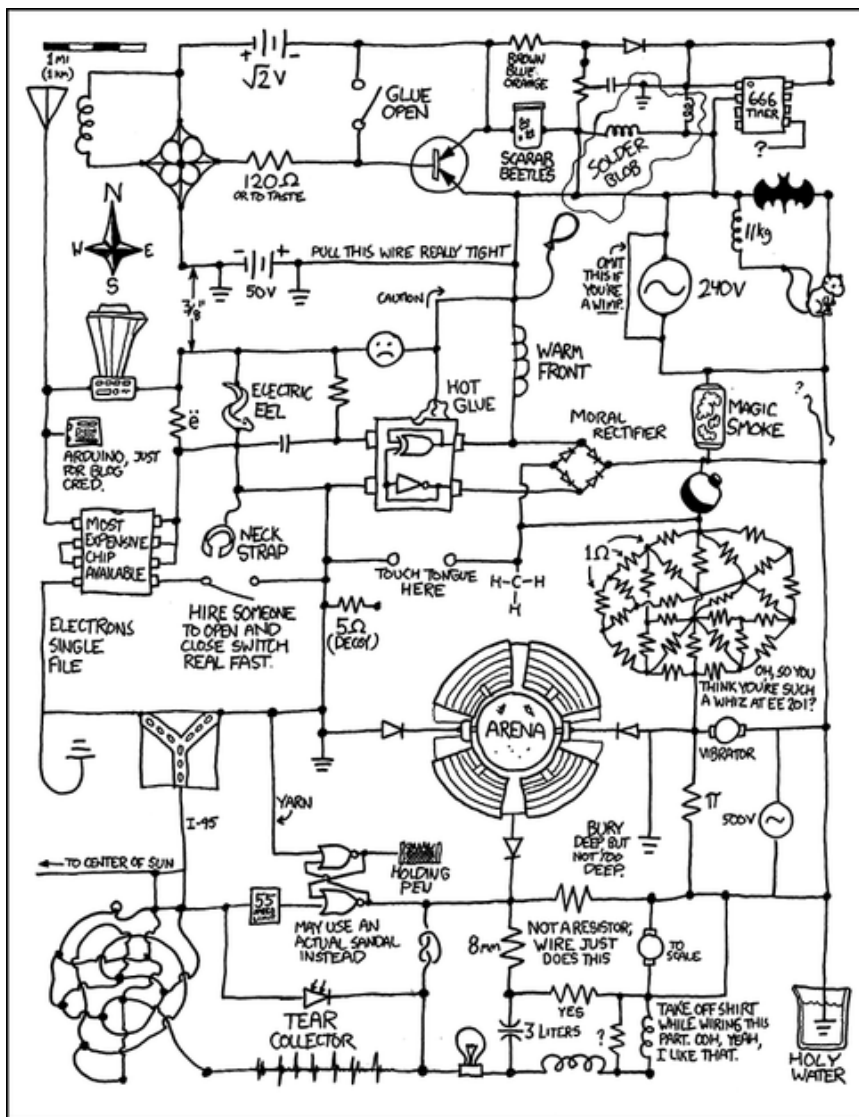

-Randall Munroe (1984 – current)

There has been a variety of investigations in the field of emotion research with regards to the affective physiological state. In a fundamental work in the area, Picard et al., (2001) set out a set of five “factors” in eliciting emotion:

1. Subject-elicited vs. event-elicited: Does the subject purposely elicit emotion or is it elicited by an external stimulus or situation or task?
2. Lab setting vs. real-world: Is the subject in a lab or in a special room that is not their usual environment?
3. Is the emphasis on external expression or on internal feeling?
4. Open recording versus hidden recording: Is the subject aware that he/she is being recorded?
5. Emotion-purpose versus other-purpose: Does the subject know that he/she is a part of an experiment and the experiment is about emotion?

With respect to our study, these questions are easily answered as; 1) "Event-elicited" 2) "Lab setting" 3) "Internal feeling" 4) "Open recording" 5) "Emotion-purpose". This would be a broad overview of where our experiment fits in the spectrum of possible experiments. However there is a long list of smaller details that are of importance in the overall experimental design.

In this section we will visit the rationale behind the experiment design and what data we are collecting. We then cover how we achieve discriminant validity. We examine the discriminant validity of the induced emotional states, and examine how the reported emotional experience will also be validated. We then take a look at somatovisceral responses as a special case of validity checking. The responses concern much of the functioning of internal organs and are a difficult subject because they are controlled by more than just emotion. Lastly we look at how we will construct an experimental participant group.

While this chapter is rooted in psychological methods, the next chapter “Method and Materials” elaborates on practical and technical aspects of the work.

6.1 Synopsis

The goal of the experiment on which this work is based is to determine if any correlation exists between physiological signals and human emotional state. The experiment will take a set of subjects and stimulate emotional responses. The stimulus (IAPS slides) are not considered the cause of the physiological effect (response) because we do not know exactly how someone will react emotionally. Instead the elicited emotion is studied as the cause of the physiological response. The elicited emotion is determined via the participant's self report of their emotional state after each stimulus slide was applied. Physiological data was collected from participants and used for later analyses in an attempt to find correlations between the signals and their emotional state.

The experiment has, by nature, a lot of variables. We have tried to control as many as possible. The person was "at rest" before the experiment starts, having sat in a chair for 10 to 15 minutes prior to data collection (this time is used to connect sensors and test signals). The participant was seated at all times, which removes a great deal of extra physiological signals that would be present in ambulatory systems.

By design, many of the induced emotions are not intended to be strongly present and this has a major effect on classification tasks. Experiments that use a very strong emotional stimulation will, presumably, observe more distinct emotional responses. We focus however on smaller emotional reactions as may occur in the normal work/home environment. We do not know if our results could be extrapolated to monitor more potent emotions found in military, medical, legal or in police and emergency services. The goal of this work is more concerned with emotions from visual stimulus which occur when a person is not ambulatory, such as would be relevant to emotions felt while watching movies, playing video games, viewing web pages, working at a desk or possibly even driving a car.

We regulated room temperature and lighting conditions, as much as possible, to keep them constant. Factors in the experiment include the elicited emotions, the people involved, mood prior to the experiment, and influences of medication, drugs, caffeine, cigarettes, alcohol.

The stimulus procedure chosen is the International Affective Picture System, IAPS. The effects of this stimulus is well understood and the safety and suitability for the laboratory is excellent.

Our slide show experiment was designed to progress in four stages:

1. Introductory slides to familiarise the user with the environment;
2. Stimulus slides followed by rating tasks;
3. Simulated crash of the computer running the experiment followed by rating task;
4. A “thank you for participating” slide.

6.2 Data Collected

The data collected was in three categories:

- Participant information;
- Self assessment of emotional reactions;
- Physiological signals at rest (for a baseline) and during stimulus.

Participant information included a person’s height, weight, age, gender and feeling (type of day so far). The self assessment of emotional responses was collected using a 9 point Self Assessment Manikin as published by Lang et al., (2001) and depicted in Figure 138.

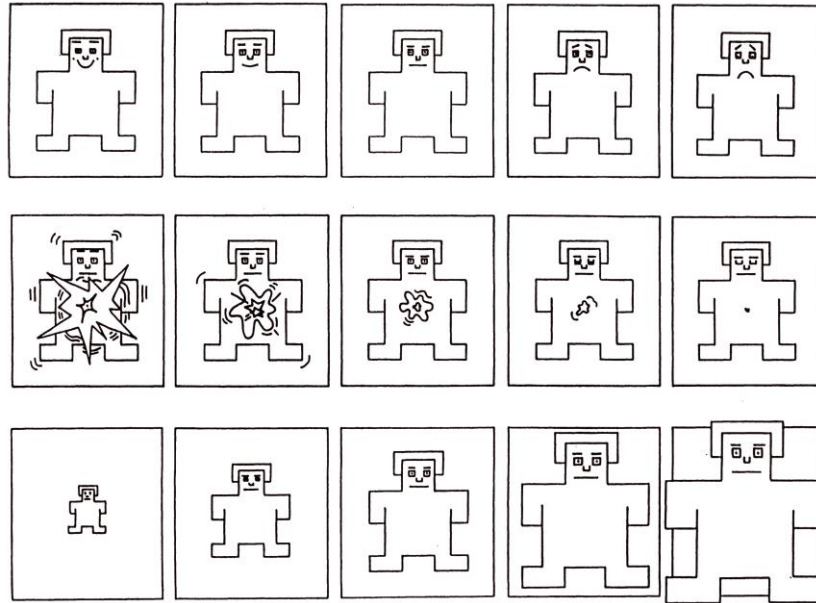

Figure 138: Self Assessment Manikin

Physiological signals measured were Electrocardiogram (ECG), Blood Volume Pulse (BVP), Galvanic Skin Response (GSR), Electromyography (EMG) for the corrugator muscle, skin temperature for the finger, respiratory rate and pressure exerted by hand onto feedback apparatus.

These data items were chosen because they appear often in PPR literature and were identified as significant in our literature review. They also meet the secondary objectives of being readily available for the encoding equipment being utilised as well as being non-invasive and easy to record with low cost hardware.

6.3 Design

An essential goal in the design of our experimental design is a high internal validity of the investigation (Campbell, Stanley, & Gage, 1963). That is to say, the likelihood of the primary hypothesis must be substantial in comparison to any alternative hypothesis.

In a psycho-physiological study, one of the most substantial rival hypotheses is that influences other than emotion are either; responsible for the somatovisceral (nerve pathways between the spine and the internal organs) responses observed; or have

created so much noise as to disguise the effect of emotion (Stemmler, 2003).

Somatovisceral responses are broadly influenced by many other factors including:

- Homeostatic activity to maintain body temperature or other balances (e.g. iron or sugar) (Brentson & Cacioppo, 2007);
- Posture (Akselrod & Oz, 1997);
- Activity / task (Ekkekakis, 2005);
- Task difficulty / mental effort (Mulder, Mulder, & Veldeman, 1985);
- Direction of attention (Lacey & Lacey, 1974);
- Anticipation (Mantysaari, Antila, & Peltonen, 1988);
- Thoughts (Lang, Kozak, Miller, Levin, & McLean, 1980).

Stemmler (Stemmler, 2003) outlines five different (valid) experimental designs that are commonly used in experiments involving emotional elicitation in a psychophysiological context:

1. Comparison of different emotions in different contexts;
2. Comparison of different emotions in the same context;
3. Comparison of different emotions in different intensities;
4. Comparison of one and the same emotion across different contexts;
5. Comparison of emotion with its induction context.

We are using the second design “Comparison of different emotions in the same context” as our reference in this work as it best suits our experimental objectives.

As is well known, the social sciences rarely produce research that gives a “yes or no answer”. This is largely due to the fact researchers need to analyse non-quantitative (and/or abstract) constructs, such as level of pain or enjoyment. (John & Benet-Martínez, 2000). These constructs very rarely exist independently, because many cognitive physiological and emotional processes are interlinked. We will use construct validity (Campbell & Fiske, 1959) to quantify if these interactions have been sufficiently “untangled” in the experimental design. Our goal is to show that it is likely we are in effect testing the desired construct.

For an experimental design to be regarded as having excellent construct validity, it must demonstrate that its constructs satisfy convergent validity (Campbell & Fiske, 1959) and discriminant validity (Campbell & Fiske, 1959). Convergent validity tests whether constructs believed to be related are related, whereas discriminant validity tests if constructs believed to be un-related are un-related. Unfortunately discriminant validity and convergent validity do not give yes or no answers; often the result is in the form of “independent enough” or “sufficiently related” respectively.

In this section we will explain how our work meets validity requirements in terms of induced emotions, participant feedback and the nature of whether our recorded somatovisceral responses can be expected to relate to the emotional state.

6.4 Discriminant Validity of Emotions Induced

To be able to show discriminant validity (Campbell & Fiske, 1959) for emotions, it is necessary to induce each emotion at least twice (Stemmler, 2003). In this way a response that happens twice in that emotion can be said to be more likely the result of the stimulus and not of some other factor. Additionally, the emotions must be elicited in the same context as they may present differently in a changed environment.

Care must be taken such that the environment in which emotions are elicited presents minimal emotional stimulus in itself. Factors to be controlled include:

- Room colour scheme (Danger 1987);
- Smells / odours;
- Responsiveness of the user interface (Trimmel, Meixner-Pendleton, & Haring, 2003) & (Boucsein, 1988);
- Branding of computers used (Fitzsimons, 2008);
- Lighting comfort (Chauvel & Perraudeau, 1995);
- Lighting levels (Schneider & Leitenbauer, 2010).

Many of these points are discussed in more detail in Chapter 7.

An initial task was to select a set of slides for the purpose of stimulating our participants. The following criteria were identified as the basis for selecting stimulus events:

1. Slides should be chosen so as to stimulate a broad section of the Arousal / Valence / Dominance emotional space;
2. Self assessment ratings for the slides used should have a low standard deviation in previous experiments (i.e. the outcome is predictable);
3. Around 30 slides is an ideal show length, it is not too taxing so as to bore participants, and allows adequate coverage of the types of stimulus available in the IAPs data set;
4. Slides that have been used in multiple studies and continue to produce consistent self reports are considered more reliable than the rest of the population;
5. Where applicable, slides that produce a similar response in male and female participants are preferable to those that don't as keeping the slide shows similar helps us compare male and female reactions to a similar stimulus;
6. For stimulus events that are highly gender specific (e.g. eroticism) separate slides should be used for male and female participants. However the self report rating should be very similar for the two slides;
7. Slides should not have any obvious cultural bias that would reasonably cause our Australian participants to feel different about the stimulus (for example, no flags or US dollars);
8. Slides should be suitable for viewing (not overly graphic, sexual or instructive) so as to comply with Western Australian laws;
9. Slides should not be overly dated (70's hair styles, old model cars, etc.).

To find a slide show which exhibited all of these criteria we used both mathematical optimisation of the quantifiable objectives (1-6) and manual refinement to meet the "human" requirements (7-9).

This formal evaluation of slide selection by a set of 9 criteria is in excess to the processes normally employed. Currently most studies employ the judgement of the

investigator to weigh SAM data from reference studies and their own experimental objectives, for example:

“All pictures contained humans or human faces, were matched for complexity and rated for emotional content” (Baumgartner, Esslen, & Jäncke, 2006) – On the selection of 48 IAPS images.

“...which contained 48 to 55 slides. Slides were divided into nine subsets that were based generally on technical reports from Lang and colleagues (e.g., Land et al. 1995; Lang & Greenwald 1981).” (Cacioppo & Lang, 1998)

“90 pictures were selected from the IAPS consisting of 30 pleasant, 30 neutral, and 30 unpleasant pictures based on the valence and arousal ratings” (Schaaff & Schultz, 2008)

“Our stimuli consisted of 24 pictures selected from the International Affective Picture System (IAPS).⁵ We chose mildly unpleasant and arousing [stimuli] to avoid confounding valence with arousal.” (Wise & Kim, 2008)

The optimisation of objectives 1-6 was achieved by means of an evolutionary algorithm that had a capacity for allowing the user to exclude undesirable slides. The software is available on request to the author, as guidance is needed, and is depicted in Figure 139.

The evolutionary algorithm (EA) operated by using populations of potential slide shows. These populations were subject to simulated evolutionary refinement in which a fitness metric was used to determine whether a potential slide show was a good candidate for further refinement in the next generation of the population being simulated.

The fitness of any member of the population (a full two slide shows for male and female) was calculated by:

- A percentage metric concerning coverage of emotion space (P) (often near 100%);
- Measurements of standard deviation performance of each slide, averaged over the set (D).

In calculating D , any slides that have performed well over multiple studies were weighted down by 0.2 standard deviations per study (matrix W). This weighting, (value determined by trial and error), guided the EA towards meeting criterion 4.

A male/female slide deviation metric was then calculated as the difference in average rating per slide (taken from the largest applicable study) averaged over the set and then normalised to be expressed as a percentage. This was performed separately for Arousal, Valence and Dominance to produce three gender metrics, one each for Arousal, Valence and Dominance, G_a , G_v , and G_d respectively. This helped guide the EA towards meeting criterion 5.

The final fitness (F) was calculated by: $F = P. (-D.W + \frac{3}{8}G_a + \frac{3}{8}G_v + \frac{2}{8}G_d)$. Note the Dominance portion of G was given unequal weighting as its use in affective literature/research is not as common. In this respect we felt most of our classification tasks were likely to revolve around the Arousal/Valence dimension.

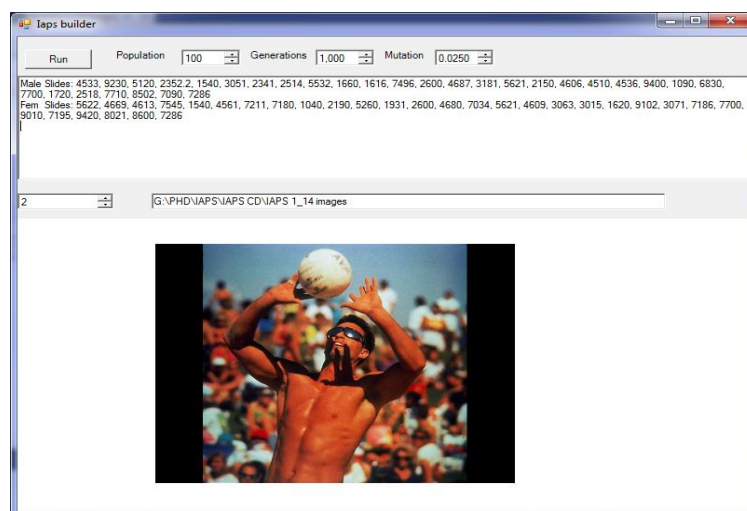

Figure 139: Software for IAPS show optimisation.

The evolutionary algorithm produced a slide show which was then manually examined. We manually rejected slides to meet the “human” requirements (7-9) regarding cultural applicability, legal/ethical viability and dated (1980’s) appearance of some material. With these slides rejected from all future sets, the evolutionary algorithm process was then re-run. This back process of computation and human validation was repeated until a suitable slideshow was produced. The final selection of slides is described in Table 9.

A final slide was added to the experiment, this slide was a simulated crash screen; the objective was to convince the participant that the computer controlled simulation had just crashed. It should be noted that the simulated crash at the end of the show is not a vital part of the experiment. It is a stimulus of emotion at a different level to other presented stimuli, and there is only one attempt per participant at “user frustration”, which does not allow us to confirm with any certainty that any changes recorded are due to frustration. We included the test as a general aid to any post hoc analysis because A) frustration is an emotion common to the field of Human Computer Interaction (HCI) ; B) It may serve as a potential “high barometer reading”, that is if the user is annoyed/entertained by the crash screen, or the hoax, or the beeps from other equipment, we establish reactivity levels for more potent emotional experiences.

Table 9: Stimulus for experiments

Slide Description	Slide Topic	IAPS #	Participants	
			Male	Female
Windows Crash Screen	Frustration	NA	Y	Y
Snake (ready to strike)	Danger	1050	Y	Y
Big Hairy Spider	Danger	1200	Y	Y
Angry Dog	Danger	1300	Y	Y
Male Face (smile)	Faces	2000	Y	Y
Human Baby	Faces	2070	Y	Y
Kids playing	Fun	2345	Y	Y
Boy with bison (head in arse of)	Humour	2730	Y	Y
Boy Crying	Faces	2900	Y	Y
Abortion	Mutilation	3062	Y	Y
Hand Cut up	Mutilation	3150		Y
Girl (½ head blown away)	Mutilation	3069	Y	
Hospital Patient (male)	Danger	3220	Y	Y
Male nude (discreet)	Erotic	4520		Y
Female Nude (discreet)	Erotic	4005	Y	
Male lifting weights	Suggestive	4535		Y
Female bikini	Suggestive	4150	Y	
Handsome fireman	Erotic	4572		Y
Female (pornographic)	Erotic	4300	Y	
Couple at beach	Suggestive	4641	Y	Y
Couple Sex (discreet)	Erotic	4659		Y
Couple in bed (not discreet)	Erotic	4666	Y	
Skydiving formation	Action	5621	Y	Y
Extreme windsurfing	Action	5623	Y	Y
Flower Garden	Landscape	5760	Y	Y
River	Landscape	5780	Y	Y
Fireworks (over city)	Landscape	5910	Y	Y
Towel	neutral	7002	Y	
Mug	neutral	7009		Y
Spaghetti	food	7480	Y	Y
Tissues	neutral	7950	Y	Y
High diver	Danger	8040	Y	Y
People in a roller coaster	Action	8490	Y	Y
Graveyard	Danger	9000	Y	Y
Execution (young lady)	Horror	9253	Y	Y
Knives (subliminal words)	Danger	9401	Y	Y
Violent Scene	Horror	6550		Y
Warzone (parent with child)	Horror	9410	Y	
Dentist	Horror	9582	Y	Y

6.5 Validity of Emotions Reported

We have assessed the validity of reported emotions as stemming from three factors:

- Will the participant share their true feelings?
- Does the participant understand the task correctly?
- Is there an apparent variability inside the group of participants which would alter how emotions were reported?

A major psychological factor in human decision making and feedback of likes and dislikes is the Normative Social Influence (Raghunathan & Corfman, 2006). That is, people (generally) will automatically act in a manner that conforms to social expectations in order to gain acceptance. It has been shown that tasks performed without human presence (or human observation) are free from the effects of Normative Social Influence (Wouda, 2006). To this end the experimental environment is free of any staff for the duration of the experiment. This and other measures are discussed in greater detail in Chapter 7.

To ensure the participant understands the task correctly, a tutorial session is conducted at the beginning of the experiment. In this way, if the participant is confused after the explanations are given, we have a chance to clarify any points prior to data collection. This is also discussed in greater detail in Chapter 7.

Finally the question of whether ratings are reported accurately across subjects is a difficult task. While we can expect that if one person rates a film as 90% enjoyable, and rates another as 95% enjoyable then they enjoyed the latter film more. However if one participant rates a film as 90% and another rates it as 95%, we do not necessarily know which participant enjoyed the film more. The latter participant may just be a harsher critic. A similar effect concerns the results obtained from our experiment. In this regard we do not feel qualified to prepare a survey sheet for the emotional self report. Instead we used the already validated and accepted procedures and sheets of the Self Assessment Manikin (SAM) (Bradley & Lang, 1994).

6.6 Validity of Somatovisceral Responses Observed

As we have already covered, somatovisceral responses are dependent on several factors. The only way to have a statistically significant result is to keep as many of these factors constant and stimulate an emotion multiple times at the same intensity to see that the same response pattern presents itself.

However, there is another issue concerned with the somatovisceral responses and that is *group variability*, otherwise known as *error variance*. This concerns the variation of somatovisceral responses to affective states between participants. A primary cause of this is a phenomenon whereby individuals may have consistent somatovisceral responses to an emotional state that differs from the somatovisceral responses other group members consistently show. Stemmler (2003) describes this variability, known as individual response specificity, as very high and likely to compromise statistical power.

The inconsistency of somatovisceral responses between different participants has two parts: A) Arousal, i.e. the level of baseline Arousal; B) Arousability, i.e. the degree to which the response changes. In what is an almost universal method for accounting for this inconsistency we recorded a “baseline” prior to the regular data collection which was used to normalise the collected somatovisceral responses.

6.7 Participants

With this experiment, like many others in the field, it was difficult to obtain a large number of participants. It was our intention to obtain 50 usable sets of results (25 male, 25 Female). We succeeded in obtaining 33 participants, 5 of whom were female. After removal of participants where equipment failed, mistakes were made or physiological signal quality was an issue, we had 24 usable subjects. All subjects were recruited through the university students and faculty. The participants were not queried on their ethnical / cultural background.

There have been many small qualitative experiments and case studies in the field of physiological pattern recognition. However, to date, very little success has been

achieved in regards to creating a heterogeneous classification system that works across multiple people.

In designing this experiment we are aware that there are a great number of subject specific factors, and we wish to use a sample group large enough that individual differences do not confound the effect we are trying to observe.

Sources of individual differences (as discussed in detail in the literature review):

- Physiological signal morphology and characteristics vary between people;
- Physiological manifestations of emotion will change from person to person;
- Emotional response to images varies from person to person;
- Description of emotion varies from person to person;
- External factors of mood and other emotional events prior to the experiment.

By using a self report of the resulting emotional state, not the emotion we intended to create, we eliminate many sources of individual differences. This means that our experimental procedure needs to compensate for individual changes in physiological signal morphology and individual physiological manifestations of emotion.

6.8 Conclusion

Ideally this experiment would have utilised 50 subjects' results (25 male, 25 Female). However we obtained 33 participants – (28 male, 5 female). Each participant was shown 32 slides, from the IAPS dataset, to stimulate multiple emotions multiple times. Several slides were different to suit the predicted reactions of male and female participants. The slides were shown in the same (randomised) order to each participant. This may have altered results to some degree as strong slides (e.g. mutilation content) may affect the rating of the next slide as well, as noted by Kirsch (Kirsch, 1997). The final slide was a simulated crash of the presentation system.

During the course of the experiment we recorded the following physiological signals from each participant:

- Electrocardiogram (ECG);
- Blood Volume Pulse (BVP);
- Galvanic Skin Response (GSR);
- Electromyography (EMG) for the corrugator muscle;
- Skin temperature (of a finger);
- Respiratory rate;
- Pressure exerted by hand onto feedback apparatus (later discarded due to issues with recorded data).

Each participant reported their reaction to the slide using the Self Assessment Manikin (SAM) and the self report was later studied for correlations with the recorded physiological signals. A questionnaire was also used prior to the experiment to record the participant's height, weight, age, gender and existing mood.

In this section we visited the rationale behind the experiment design and what data we collected. We also showed the validity of the design with a lot of the attention focused on emotion elicitation and somatovisceral responses.

Essentially the design of this experiment follows the established procedures in the field closely. The only major design improvement over existing works is the application of a formalised method to select stimulus slides which used an evolutionary algorithm to balance nine selection criteria.

The novelty of this work is not related to the nature of the experiment, but rather it is attempt to improve on previous results by applying better equipment, more recording, better and wider feature extraction and examining novel ways of compensating for individual variations.

While the design of "this type of experiment" is well understood, the implementation is often poorly documented and due to the fact that the method is nontrivial, involving

many variables, the lack of documentation often comes into question e.g. (Angelica, Gül, & Kremer, 2010). While this chapter shows how we are in-line with current experimental design concepts, the next chapter “Method and Materials” is where we show the novelty in our approach.

7.0 Method and Materials

“Inventing is a combination of brains and materials. The more brains you use, the less material you need.”

-Charles Kettering (1876 – 1958)

As human emotion can be affected by many external factors, we have paid a great deal of attention to the materials and methods used in conducting this work. In this chapter we discuss our experiment construction and handling of participants in detail. In the next chapter we continue this discussion as it applies to our novel hardware implementation of the Self Assessment Manikin (SAM).

Our experiment involves using a slide show (known as the IAPS set) to stimulate the emotions of any given participant. During the course of the experiment, the participant is connected to a set of sensors which record various physiological signals. For every slide presented the participant reports how the slide made them feel using a SAM. We save both the recorded physiological signals and SAM data for further analysis (our classification task). A flow chart of this procedure is given in Figure 140.

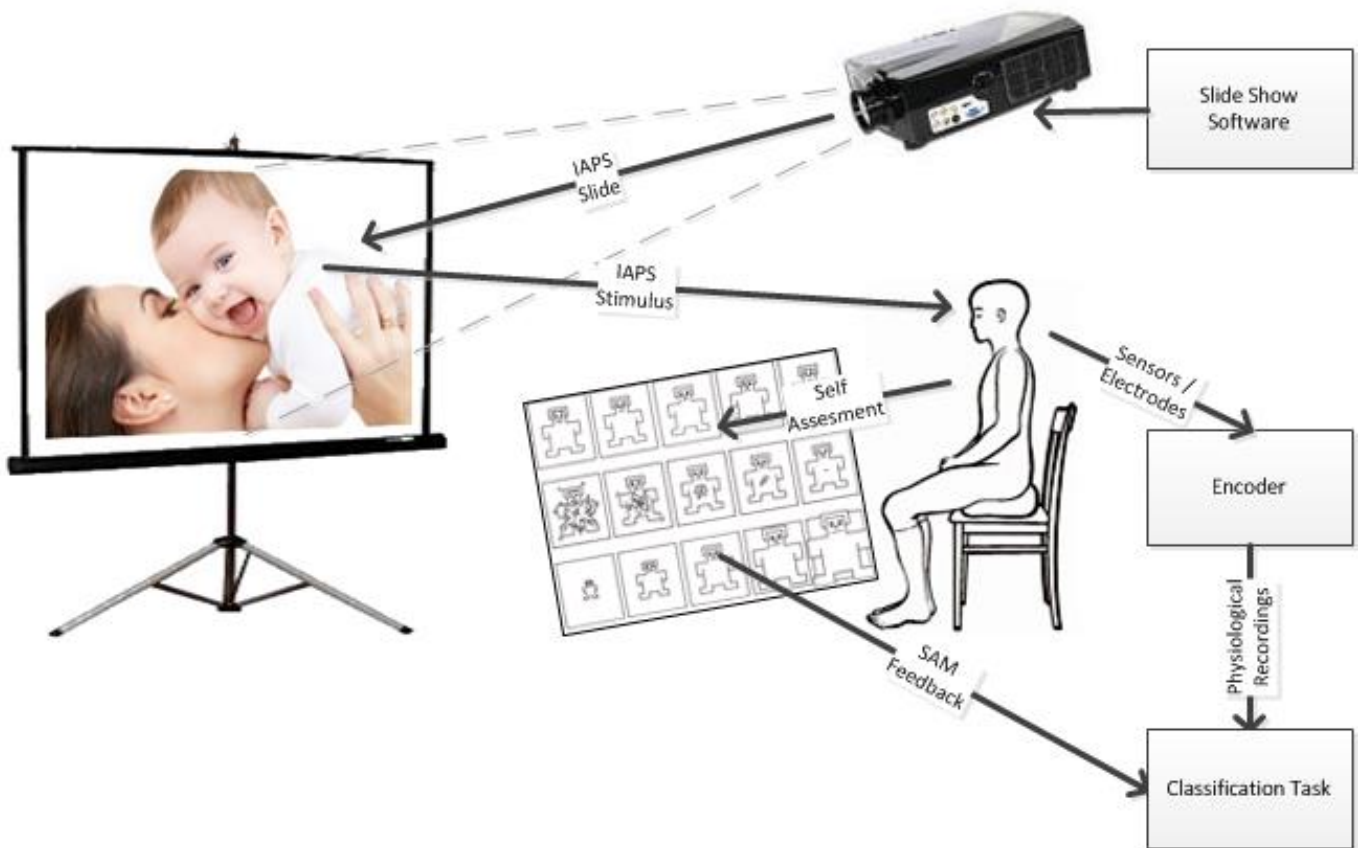

Figure 140: Overview of experiment procedure

Broadly, our method involved creating a suitable laboratory that allowed us to safely and effectively stimulate the emotions of our participants using a slide show. We seated our participants in a comfortable chair and a nurse attached the required sensors to the participant. After verification of signal quality was established and the participant had ample time to settle, the experiment began. The initial part of the experiment was a tutorial aimed at getting the participant familiar with the self assessment exercise. After the tutorial was complete and the participant was happy to continue, the data collection part of the experiment began.

The experiment involved a set of stimulus slides presented to the user. After each slide was presented, a self assessment exercise was completed using our novel hardware implementation of the “Self Assessment Manikin” (Lang et al., 2001). Each self assessment task allowed the user to report how the slide made them feel.

The final slide of the show was a hoax - a simulated computer crash. This was intended to stimulate a strong experience-based emotion rather than an induced emotion.

In this chapter we describe in detail our method in regards to our tutorial stage, room setup and handling of participants. We then discuss our safety procedures and give a technical overview of the different sensors we employed.

7.1 Tutorial Slides

The IAPS manual (Lang, Bradley & Cuthbert, 1997) recommends that a set of test images is used to allow participants to become familiar with the rating tasks before the experiment begins. This “tutorial” phase prevents confusion, which makes the emotional experience more likely to be the result of the stimulus, and not the result of uncertainty about the experiment.

After some preliminary tests, we found that our hardware SAM device should also incorporate some orientation procedures before use (see Figure 141). This would allow the user to become familiar with (and comfortable with) the device. Importantly it also allows the investigators to inspect the user’s interaction with the device and

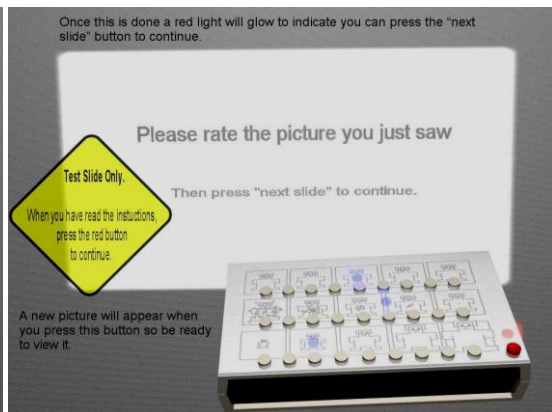
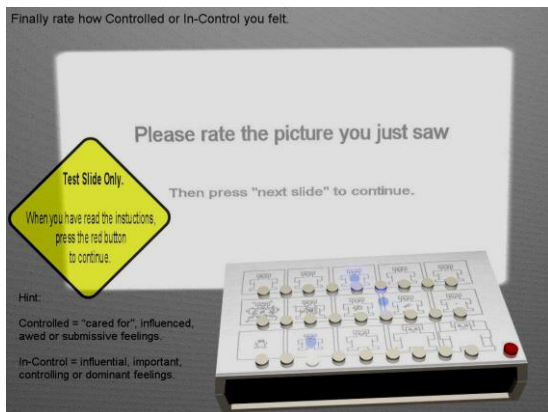
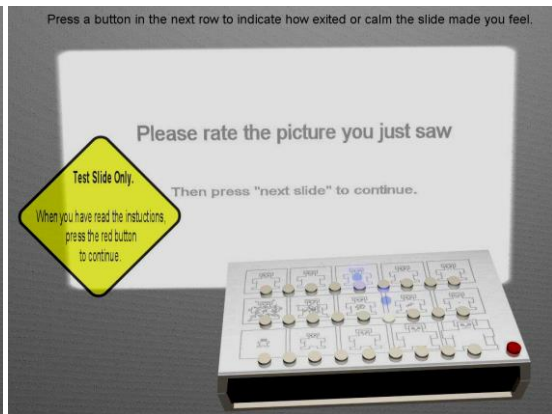
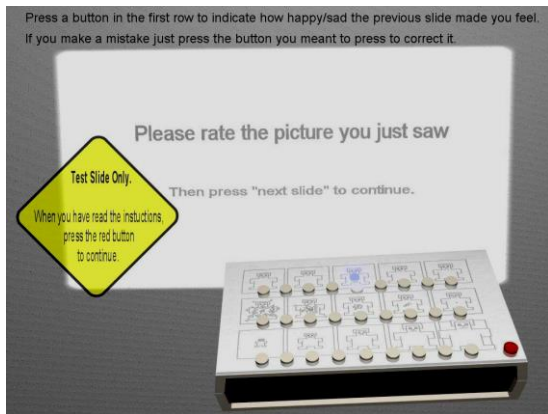
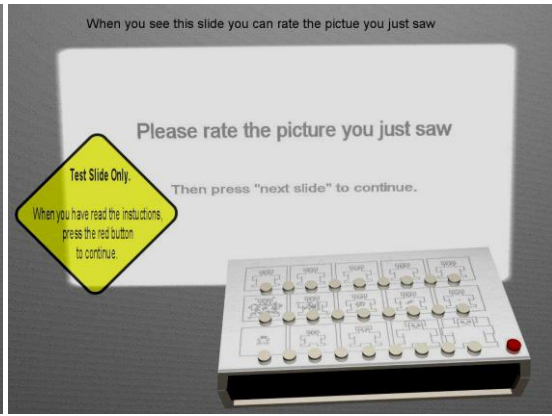
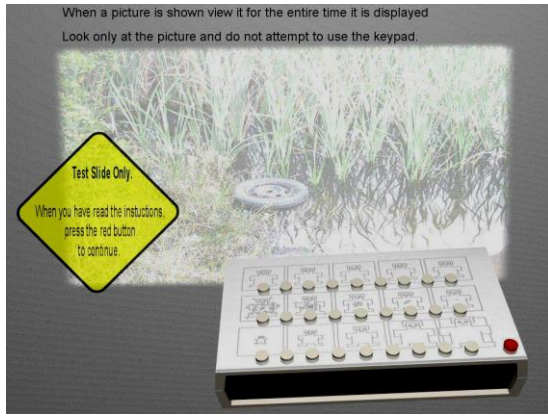

Figure 141: Introductory slides

adjust the setup, or coach the user, so that the participant remains at rest and arm movement is minimised.

A set of seven slides to orient the user with the rating procedure and the SAM feedback device were developed and are presented in Figure 141.

7.1.1.1. **Feedback Instruction**

A neutral prompt for user feedback was designed. For the purposes of completeness and comparison with other works we present our feedback prompt in Figure 142. The goals for this prompt were:

- To provide clear and easy to follow instructions;
- To not induce a strong emotion (to be neutral);
- To be clearly readable without eye strain;
- To not contain any language that invokes strong affective connotations, such as “task” “complete” or “now”. (Though the presence of “please” was deemed less influential than the absence of “please”).

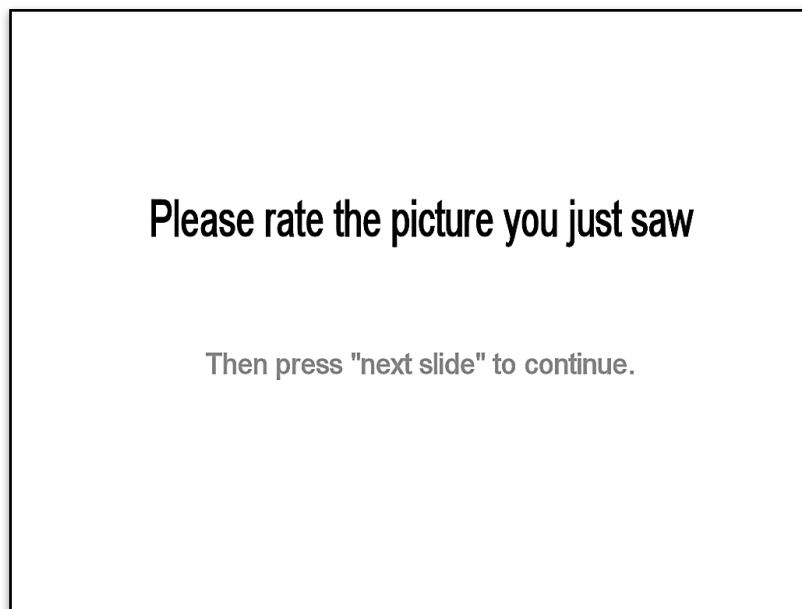

Figure 142: Feedback slide, displayed after each stimulus while the participant completes the self assessment task.

7.1.2. Simulated Crash

We wished to study the effects of a more naturally induced emotion (emotion arising from experience rather than observation). A natural emotion relevant to user interaction in computing is anger/frustration in response to a computer crash. As such we created an artificial computer crash, as the last phase of the experiment. This ruse was triggered exactly as the user pressed “next slide” during the final evaluation screen. The user was unaware that the last IAPS image was the final regular stimulus and the apparent crash seemed to be in response to them pressing a button. To complete the ruse the hardware SAM device also emitted an error beep, as if it was resetting or malfunctioning.

At this point staff in the room busied themselves with equipment and played along with the crash scenario without actively engaging the participant. After six seconds the hoax was revealed, and a final rating slide was presented (see Figure 143).

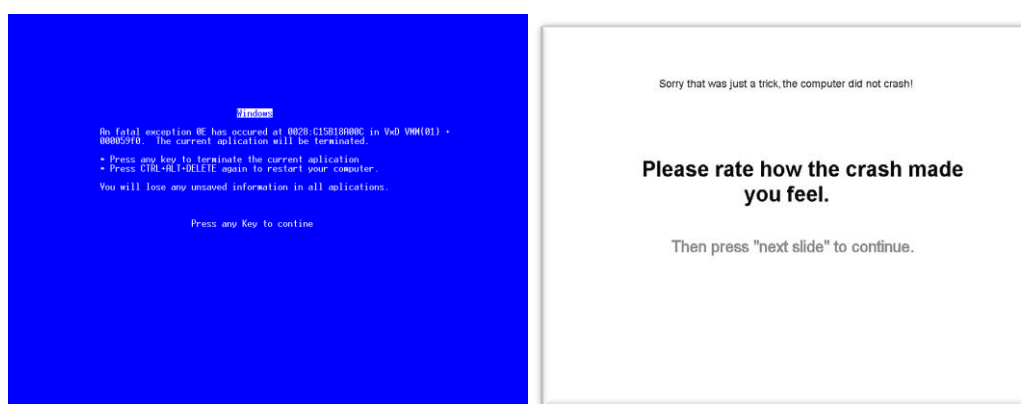

Figure 143: Crash screen (left) and crash rating screen (Right)

After the experiment the investigators would engage the participant in conversation to ascertain if they were taken in by the ruse. Most people reported some degree of suspicion about the ruse. Only three people reported being completely taken in and only two people reported being completely sure it was a hoax.

This part of the experiment did produce some very definite emotions, but they were mixed and not repeatable. Some people reported frustration believing they would need to redo the experiment, some people laughed audibly (either at the hoax or at the fate

of the experiment) and one person even reported feeling exasperated, believing she would be prevailed upon to fix the broken computer.

7.2 Room Setup

The goal of the environment being used for the experiment is to be as neutral as possible so as not to bias or interfere with the emotions being elicited. The room, shown in Figure 144, must also serve several functional aspects, such as being large enough to focus a projector unit.

A set of requirements was identified for the experimental environment:

- Affective Tone:
 - Neutral, non-clinical visual aesthetic;
 - No prevalent smell;
 - Comfortable chair for participant;
 - Appropriate furnishing;
 - Temperature.
- Lighting:
 - Avoidance of fluorescent lighting;
 - Ability to easily see projected image.
- Location:
 - Quiet location;
 - Private setting;
 - Natural lighting;
- Technical Requirements:
 - Possibility of a waiting room;
 - Low pile carpet that is unlikely to generate electro static discharge which can damage the recording equipment;
 - Isolation from nearby electrical interference, eg microwaves;
 - Compliance with electrical isolation laws for equipment attached to a human body;
 - Pass an Occupational Health and Safety inspection;
 - Room is wide enough to allow a projector to focus;
 - Separated staff and participant sections.

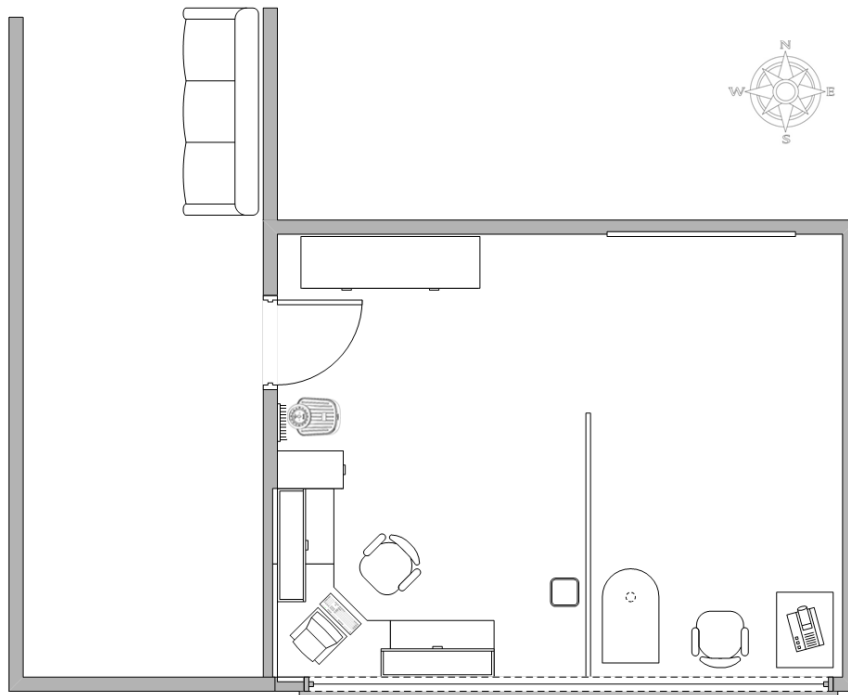

Figure 144: Experimental room, plan view.

The layout of the room, as per Figure 144, was divided into two areas divided by a partition. On the left was an (out of sight) area for the investigators to work and a seat for the nurse. On the right was the experiment area, with the SAM feedback device to the left of a comfortable chair. To the right was a cabinet containing electrodes and first aid, which was also used as a projector stand. The recording device was placed on a window ledge behind the seat.

7.2.1. Affective Tone

In deciding on the room's "look and feel" the following concerns were identified as features the room should possess:

- Neutral, non-clinical visual aesthetic;
- No prevalent smell;
- Comfortable chair for participant;
- Appropriate furnishing;
- Comfortable temperature.

Eric Danger's (Danger 1987) work on colour in interior design was referenced extensively in verifying the room's neutral tone. The room was painted with light tan and light green melamine furniture was used on the investigator's side and white melamine on the experiment side.

The carpeting throughout the building was a medium grey, and this was unchangeable for the room in question. In discussing the use of grey colours for domestic interiors, Danger advises against the use of grey in a dark room to avoid a possible "gloomy" effect. Since the room needed to be darkened to allow the viewing of projected images, it was necessary to make a check to see if this particular room would be too gloomy. This check was conducted by subjective evaluation of the room and it was determined that a darkened room would not be too gloomy given our current light colour scheme.

7.2.2. **Lighting**

The objectives of the room lighting are twofold:

- Avoidance of fluorescent lighting;
- Ability to easily see projected image.

Fluorescent lighting is a major source of power line interference in bio-signal acquisition devices. Levkov et al, (Levkov et al., 2005) examines these effects at length. Many experimenters will turn off all fluorescent lighting for bio-signal acquisition experiments e.g. (Radin, 2000), other researchers used low-pass filtering to minimise the effects e.g. (Barreto & Zhai, 2003) and (Ward, 2004). In our experiment, we opted to avoid fluorescent lighting and use vertical blinds installed in the window to modulate available sunlight to suitable conditions.

The lighting levels present in a room can be shown to control the visual comfort levels of occupants in the room (Chauvel & Perraudeau, 1995). Both sunlight and interior lighting can affect visual comfort levels of people in a room. A study conducted by the University of Manchester (Murray et al., 1998) establishes a link between glare stimulus intensity and corresponding changes in the ocular EMG. As such eye strain

by bad lighting could generate unwanted EMG signals in the same area that we wish to observe.

To remove the possibility of eye strain noise, the experiment was trialled at different times of the day using an EMG sensor. We adjusted the blinds so that good lighting was obtained. The primary objective was to keep the room dimly lit with only ambient light reflecting onto the projection screen allowing for a bright image and good contrast. Our goal was also to reduce luminance fluctuations between participants as much as possible as that has been shown to influence the elicited emotion (Schneider & Leitenbauer, 2010).

7.2.3. **Location**

The room location is something over which complete control can be exercised. Requirements are:

- Quiet location;
- Private setting;
- Natural lighting.

The experiment room was located in Perth, Western Australia, 31° 56' south, 115° 50' east. Experiments were conducted through the months September to February. The room was on the top level of a two story building in a quiet, low traffic part of the university campus.

The room was 5m by 6m with a window along the entire south side. The interior walls were constructed from plaster board and the exterior wall was brick. An air-conditioning vent was present and operational.

It was possible to focus a projector on the north wall, and vertical blinds allowed moderate sunlight in, avoiding the need to use fluorescent lighting (known to cause electrical interference with recording equipment).

7.2.4. Technical Requirements

In order to safely, effectively and practically conduct this work, several technical and practical requirements must be addressed. In this section we identify these requirements and discuss how they were addressed.

Our technical requirements were:

- Possibility of a waiting room;
- Low pile carpet that is unlikely to generate electro static discharge which can damage the recording equipment;
- Isolation from nearby electrical interference, eg microwaves;
- Compliance with electrical isolation laws for equipment attached to a human body;
- Pass an Occupational Health and Safety inspection;
- Room is wide enough to allow a projector to focus;
- Separated staff and participant sections.

As a precaution against participants arriving during an experiment and simply knocking on the door of the experiment room (thus interrupting and interfering with an experiment in progress) a waiting room was desirable. In this experiment a hallway was converted into a waiting room, which all volunteers were told to utilise in their confirmation messages if no-one had come out to meet them.

As an additional precaution, during experiments, a red flashing light was activated on a sign which indicated “experiment in progress” and “do not disturb when light is flashing”. This was 100% effective in controlling unwanted traffic.

Much of the equipment used in this experiment was sensitive to electrostatic discharge (Vinson & Liou, 1998), and as such various precautions must be taken. Firstly, all participant jackets were hung on a hook to prevent clothing based static generation. Additionally, the experiment chair and surrounding carpet were treated with an odourless antistatic spray each night before an experiment was conducted.

The room setup was subject to the Western Australian Occupational Health and Safety (OHS) inspection process and we worked with the university's OHS officer to obtain a clearance to work. The experiments were trialled to ensure everything functioned as expected.

For purposes of reviewing and reproducing the experiments a complete description of the room preparation guidelines we used will now be given along with recorded environmental parameters.

7.2.5. Our Experimentation with a Shield Room to Eliminate RF Interference

From a Radio Frequency (RF) standpoint, the ideal environment for operation of sensitive recording equipment is a shield room, and we know of one experiment using EEG recording for emotion detection which utilised such a setup (Choppin, 2000).

The shield room does however have some problems for emotion research. Generally a shield room is a windowless cage, and this environment may be emotionally intimidating.

Believing a full shield room to be impractical, especially as the only shield room on campus was 2m x 1m, with solid stainless steel walls and unnecessarily intimidating, we trialled an alternative. Our alternative setup was a room painted with a conductive (ferric) undercoat. The desired (but not achieved) result was an ordinary looking room with good RF blocking properties.

To test our theory we ordered an undercoat paint that was impregnated heavily with fine iron shavings, (approx 1kg per litre). This produced a paint effect which looked normal but may have exhibited properties to minimise external electromagnetic interference. We trialled the paint using our recording apparatus placed in a 1m² plywood box painted internally with our paint.

No significant decrease in interference was noticed and plans to repaint the room in this manner were abandoned. It is our conclusion that there are no further practical

means to eliminate external RF interference in a manner compatible with the experiment's physiological (aesthetic) objectives.

It would be possible to plaster, and dry wall an existing RF proof room to produce a fake office environment, but the expense (RF rooms cost around half a million USD) and the resulting lack of windows made this option undesirable.

7.2.6. **Our Guideline for Room Preparation (A Summary)**

To concisely summarise the body of this section we created a guideline which we referred to in our negotiations with the university in obtaining and preparing a suitable laboratory:

- a) A quiet second/third story room with a window is the ideal environment:
 - a. A window alleviates many feelings of claustrophobia;
 - b. Vertical blinds should be used over curtains or horizontal blinds to regulate light into the room;
 - c. A ground floor room with a window must not be adjacent to a walkway or area where someone may see into the room;
 - d. The room must be in a quiet area, or be sound proofed, a consideration dating back to pioneering works such as Mittelman & Wolff (1939).
- b) We proposed the same room be used for all experiments;
- c) Care should be taken in regulating how the room smells:
 - a. Many rooms that are carpeted must use anti-static spray on the floor to prevent potential damage to typical recording equipment arrangements:
 - i. Many of these sprays are sugar based and leave a sweet scent (or have other scents). We found this can be alleviated by careful product selection and by early application a few days in advance of the experiments;
 - ii. In assessing the overall smell of the room, many people will easily smell imaginary scents (Bromberg & Schilder, 1934) and not all noses are capable of recognising the same scents. It may be necessary to have several people smell the room prior to experimentation. (We used three people).
- d) Electromagnetic interference should be minimised:

- a. Adding extra shielding and toroidal magnets to all unprotected cables;
- b. Investigation of surrounding offices and a co-operative agreement to temporarily disable microwave ovens and other high voltage magnetic apparatus;
- c. Use of a shielded room is not advised. Our initial trials and investigations indicated that the "meat locker" or "mesh cage" aesthetics of these environments probably introduced more emotional noise than is warranted by the reduced electrical noise.

7.3 Procedures for Interaction with Participants

As in this experiment we wish to control human emotion, it is necessary to control how staff and investigators interact with the participants. The primary objectives are to keep the participant feeling safe and comfortable and to reassure the participant that all SAM feedback is strictly anonymous and not even known to the investigators at the time of the experiment.

7.3.1. Privacy for Honesty of Feedback

During the evaluation of the slides, it is vital that our participants have the feeling of privacy. Without this the participants will rate the slides in a manner that conforms to social expectations (Raghunathan & Corfman, 2006). It has been shown that HCI tasks performed without human presence (or human observation) are free from the effects of Normative Social Influence (Wouda, 2006).

A broad range of emotion research experiments will often have the experimenter, and all staff, leave the room for the duration of their experiment. Examples of such experiments include (Isbister, Höök, Sharp, & Laaksolahti, 2006), (Hamm, Greenwald, Bradley, & Lang, 1993), (McManis, Bradley, Berg, Cuthbert & Lang, 2001), (McCraty, Atkinson & Bradley, 2004), (Sandt, Sloan, & Kareem, 2009), (Stevens, 2001), (Gotlib, Krasnoperova, Neubauer-Yue, & Joormann, 2004), (Arch & Craske, 2006) and (Spangler, Emlinger, Meinhard, & Hamm, 2001).

However our room setup did not allow for the staff to easily leave the room as the recording equipment (computer) needed to be manned and it was not possible to keep it in another room. To allow visual privacy for the participant, a partition was erected which all staff would remain behind for the duration of the experiment, often with the nurse leaving the room so as to greet the next participant in the waiting room. Similar use of partitions has been successfully demonstrated in works such as (de Wied & Verbaten, 2001) and (Kut et al., 2011).

7.3.2. **Recruitment and Pre-experiment Contact**

To recruit volunteers, an MP3 player prize was used as encouragement (the experiments were conducted at a time (2004) when this was still an expensive luxury item and adverts were placed around the university campus (see appendix 14.6). Flyers were also handed out during lectures (see appendix 14.6).

Upon being contacted by a volunteer, an e-mail with a generalised informative response (see appendix 14.8) was sent out along with a timetable of available time slots. If contact was made by phone, a similar explanation was given and a time booked if the participant chose to proceed. All participants were asked to avoid alcohol, cigarettes and coffee for three hours prior to the experiment.

7.3.3. **Entrance Procedure**

When a participant entered the room, the staff present introduced themselves and the nurse present (dressed in uniform) identified herself as a nurse. The investigator then asked if the participant has had a cup of coffee in the last three hours or had smoked in that time. As the confirmation email requested that they not do this there were no instances of needing to send participants away for smoking / drinking / drug use.

The participant was asked to turn off and place their mobile phones and any other electric (or bulky) items in a tray. Any coat / jumper the participant was wearing was placed on a hook by the door.

The nurse then asked (or measured as needed) the participant's height, weight and age. A ruler was stuck to a wall and a set of scales was available to assist with this. The details were written on a piece of paper (in a manner in which was apparent to the participant) with a code for that participant written on top.

The participant was informed (again) that all feedback was anonymous and shown that he/she was only represented by a code in our recordings. The idea of the initial survey was in part to demonstrate this fact. With these details disclosed the participant was then asked to sign a consent form, which stated the participant may be exposed to some strong images.

The participant was then led to the experiment area and seated by the nurse who struck up a polite but directed conversation about the participant's day. The generalised direction of the conversation was to find out what sort of a day that participant had had and how the participant was feeling. The results were later (privately) annotated to the participant's survey sheet.

CODE	<u>D 5 A9</u>
Height	<u>177cm</u>
Weight	<u>112kg</u>
Age	<u>51</u>
Gender	<u>M</u>
"fine"	

Figure 145: The participant survey sheet, the annotation below was made without the participant's knowledge.

After the participant was seated, the nurse attached the electrodes and answered any questions the participant had. The investigator then instructed the participant how the SAM feedback device works and coached the participant in using the device in such a manner as to minimise muscle movement. At this point the participant was reminded that the investigator cannot see the responses being made by the user and that all feedback is anonymous.

7.3.4. Exit Procedure

After the experiment was completed, several actions were taken, the first of which was the final slide (Figure 146) which requested that users allow the nurse to remove their sensors. Many participants naturally tried to remove the sensors, either to expedite proceedings or show helpfulness. This needed to be avoided as the sensors were delicate and best handled by the nurse on duty.

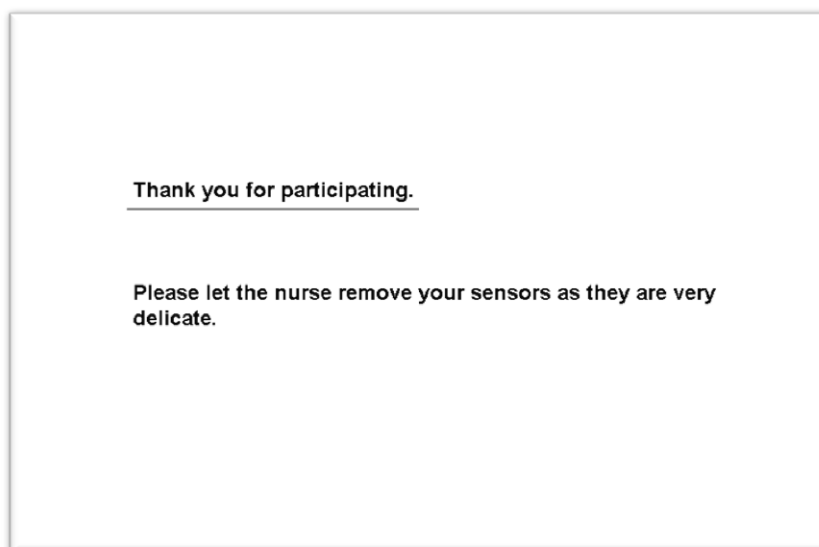

Figure 146: Final slide

After removing the sensors, the nurse would check the skin where sensors were removed for any sign of rash or allergic reaction (no instances found). All personal items were returned to the participant and the investigator enquired how the participant was feeling and if they felt any ill-effects from participation. The experimenter then explained the importance of not discussing the slides, or the crash, used in the experiment with anyone so as not to influence any other potential volunteers.

All used electrodes were then disposed of in a biohazard sharps container. The nurse and experimenter then prepared the laboratory for the next participant, including full cleansing of all equipment with isopropyl alcohol.

7.3.5. Ethical Treatment of Humans

A risk report (Appendix 14.7) used to gain Occupational Health and Safety (OHS) and ethics approval found less than 0.01% chance of emotional distress occurring to a participant. As a precaution against any emotional distress, a free and immediate counselling arrangement was obtained from the university student counselling services, such that anyone feeling any after effects could immediately seek help. All participants were asked about any negative effects after the experiment and were given a piece of paper indicating how to obtain counselling should they feel they need it in the future.

As an added safeguard, the Hardware SAM device contained an emergency stop button that allowed users to immediately shut down the image viewing process if they did not wish to continue (it was never used).

No participants reported emotional distress or used the opportunity for counselling. Generally participants reported the experiments as an enjoyable, or interesting experience.

7.4 Safety

As described previously, physiological damage was a possibility during this experiment, but there existed several other safety issues that needed addressing, namely:

- Electrode isolation;
- Electrical safety requirements (AS3200 & IEC6060-1);
- Biohazards;
- Possible allergens.

7.4.1. Electrode Isolation

A conventional city power grid carries with it dangers of "power surges" which are brief but extremely high voltages on the utility line that may propagate through transformers and damage low voltage electrical equipment and anyone attached to said equipment. These surges may be caused by lightning, accidental energisation, inducted voltages or equipment malfunctions. In the event that a power surge in a power grid is transmitted to equipment connected directly to a person the risk of fatality is very high. For this reason it is vital that all electronics be optically isolated (see Figure 147) from the conductive path to the main power grid. Often this means using batteries to power the data acquisition unit and communicating to mains attached machines via an opto-isolator, as per (Douglass, 1998).

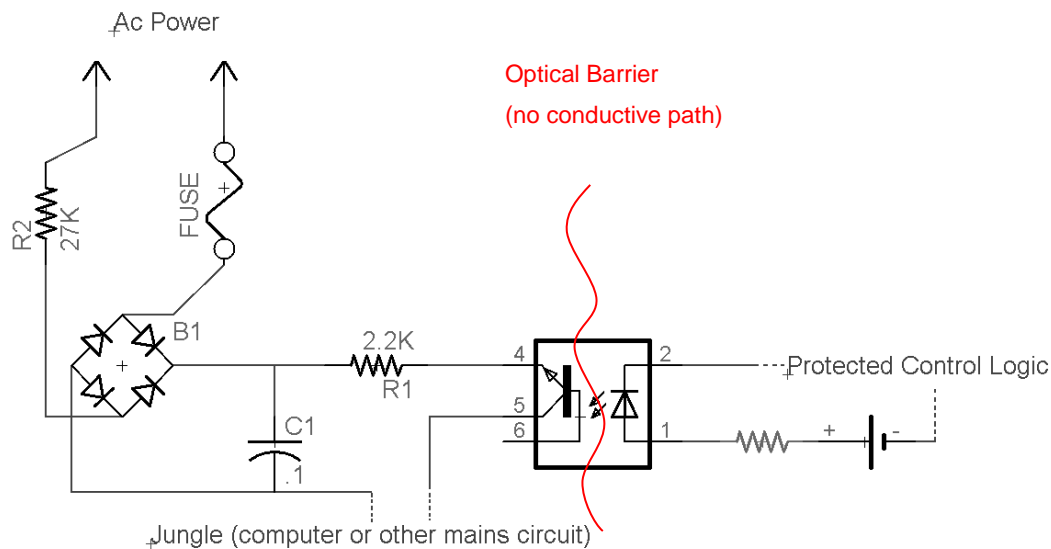

Figure 147: An example opto-isolator circuit

In general, opto-isolators should withstand input-to-output voltages up to 10 kV and voltage transients with speeds up to 10 kV/ μ s (Joffe & Lock, 2010, pg 279). In the case of the ProComp Infinity encoder we utilised, the optical isolation included a length of optic cable which served as the only link between mains operated equipment and battery operated equipment.

7.4.2. **Electrical and Biohazard Safety Requirements (AS3200 & IEC6060-1)**

The risks of power surges in regards to attaching electrodes to a human are not completely mitigated by optical isolation. There exist other means by which the electrode leads may become energised other than a power surge propagating through the recording equipment. Most of these risks stem from other electrical equipment in the laboratory environment.

As this experiment was conducted in Australia and utilises electrodes connected to people, it is subject to The Australian/New Zealand AS3200 standard (Committee EL/18/1, 1986) which, for our purposes, is functionally equivalent to the relevant AAMI/ANSI standard IEC6060-1 (Berson et al., 2010) which would apply in other countries.

As identified by the equipment manual (Thought Technology Ltd, 2003) the following sections of the relevant AS3200/IEC6060-1 standards were addressed:

- Do not operate Active Sensors within 10 feet of an operating cellular phone, similar radio transmitting device, other powerful radio interference producing sources such as arc welders, radio thermal treatment equipment, x-ray machines, or any other equipment that produces electrical sparks:
 - All phones turned off including volunteers and adjoining office space;
 - Signs posted to prevent unwanted transmissions (see appendix 14.6).

- Computers, printers and any other equipment used with medical devices be electrically isolated from line voltage to UL or CSA medical safety standards:
 - Building power already up to standard.

- The PC used with the device must be placed outside the patient/client environment (more than 3 meters or 10 feet) or the PC must comply with EN60601-1 (system safety):
 - PC compliant and at more than three meters away by partitioning;
 - All other devices compliant and properly isolated with shielded and insulated solid ducting around all cables in the recording area.

- After use, the Disposable Electrodes may be a biohazard. Handle, and when applicable, dispose of these materials in accordance with accepted medical practice and any applicable local, state and federal laws and regulations:
 - Biohazard "sharps container" used for disposal, final disposal via approved service.

- Reusable electrodes present a potential risk of cross-infection especially when used on abraded skin, unless they are restricted to a single patient or sterilised between patients. If sterilising electrodes, employ only gas sterilization:
 - Reusable electrodes sterilised correctly by appointed nursing staff.

- The operator is responsible for ensuring the safety of any devices controlled or triggered by the equipment or software, or by any software or hardware receiving data from the equipment. The equipment must not be configured or connected in such a way that failure in its data acquisition, processing or control functions can trigger patient feedback stimulus that poses an unacceptable level of risk:
 - All relevant equipment (SAM device and projector) were verified for this purpose and used with approval of the occupational health and safety department.

- Use of any equipment in a biofeedback context should be immediately terminated upon any sign of treatment-related distress or discomfort:
 - Emergency stop buttons in place and relevant procedures rehearsed by all staff.

7.4.3. **Biological Hazards**

As used electrodes represent a biohazard they were disposed of in a biohazard sharps container. All nurses wore gloves and were responsible for cleaning/sterilising all non-disposable parts of the apparatus and sensors which came into human contact.

7.4.4. Possible allergens

All substances with known allergic potential were identified and staff were trained to identify effects. Volunteers were questioned if they had any known allergies before electrodes were attached. The electrode gel used by this experiment is not known to have caused any allergic reactions, but was treated as though it may be an allergen as a precaution.

Sources of allergens identified:

- Natural rubber tubes on respiration sensor;
- Electrode gel (precautionary);
- Isopropyl alcohol used in swabs, skin cleansing and device sterilisation.

7.5 Equipment Capabilities and Application

This section describes our sensor and recording equipment. We show how it was configured and what placements were made.

7.5.1. Encoder

The recording apparatus used was a ProComp Infiniti (Thought Technology Ltd, 2003) which has been used in many related works. eg. (Strauss et al., 2005), (R.L. Mandryk, Inkpen, & Calvert, 2006), (Yannakakis & Hallam, 2008) & (Nakasone et al., 2005).

The Encoder has a 14bit Analogue to Digital Converter with a Least Significant Bit (LSB) Magnitude of $207\mu\text{V}$. The encoder has a 3dB response with eight channels, two of which sample at 2048 samples per second and the other six at 256 sample per second. Anti-aliasing is done in hardware with a 5th order Butterworth filter for a typical result of 30db Alias rejection. The encoder noise is $150\mu\text{V}$ (RMS). The single encoder unit ensures all readings are synchronised.

7.5.2. The EMG Sensor

The Electromyography (EMG) sensor detects electrical activity produced by muscle cells during neurological activation.

A "MyoScan™ pro" pre-amplified surface electromyography sensor was used with the ProComp Infiniti channel B for RAW sEMG (2048 samples/sec). This sensor has been used in various medical studies, e.g. (Nakasone, Prendinger, & Ishizuka, 2005), (I.-M. Lin & Peper, 2009), (Winkel, Younger, Tomcika, Borckardtc, & Nash, 2006), (Bohbot, 2010) & (Bitter et al., 2007).

According to international standards (Merletti & Torino, 1999) on reporting EMG data, it is necessary to disclose the following information about our experimental EMG setup:

- Electrode material;
- Electrode shape (discs, bars, rectangular, etc.);
- Size (e.g., diameter, radius, width x length);
- Use of gel or paste, alcohol applied to cleanse skin, skin abrasion, shaving of hair, etc.;
- Inter-electrode distance;
- Electrode location, orientation over muscle with respect to tendons, motor point and fibre direction.

We used the "Thought Technology" T3404 electrode strip, as shown in Figure 148, separated into individual electrodes. The electrode was a circular (10mm diameter) Ag/AgCl, (aka standard silver-silver chloride electrode) 'bulb'. The skin cleaned with isopropyl alcohol based medi-wipes, the electrode has a 0.5% saline base gel. The electrodes were placed to record the activity of the Corrugator Supercilii as specified by Cram et al., (1998). The placement used two electrodes placed 10mm apart following the muscle fibres of the Corrugator Supercilii. The earth electrode was placed at the bony prominence of the scalp just below the hair line. This muscle placement is described in more detail in section 5.8.

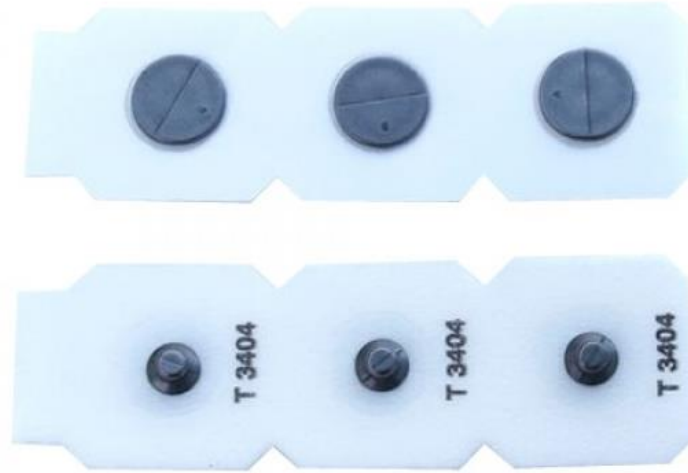

Figure 148: Thought Technology T3404 three-strip Uni-Gel electrodes (unseparated)

The standards (Merletti & Torino, 1999) also specify reportable items for detection mode and amplification, namely:

- Configuration; monopolar , differential, double differential, etc;
- Input impedance;
- Common Mode Rejection Ratio (CMRR);
- Signal-to-noise ratio (SNR);
- Actual gain range used.

The input sensor is based on a differential amplifier, impedance of the sensor is 1,000,000M Ω in parallel with 10pF and the CMRR is -10dB.

Lastly the standards (Merletti & Torino, 1999) state the filtering of the raw EMG should be specified, specifically:

- Filter types (e.g., Butterworth, Chebyshev, etc.);
- Low and/or high pass cut-off frequencies;
- slopes of the cut-offs (dB/octave or dB/decade).

As the power density function of EMG signals fall almost exclusively in the range 10 - 450 Hz, a band-pass amplifier filter is common. The MyoScan-Pro sensor used offered a three mode selectable band-pass filtering mechanism, which we experimentally determined performed best in our setup in its widest mode (20-500Hz). As the band pass filter went up to 500Hz a minimum sampling rate of 1000Hz (500x2) is required as per the Nyquist theorem.

7.5.3. The ECG Sensor

The Electrocardiograph is often abbreviated to ECG or EKG (from the German Elektrokardiogramm). The ECG is similar to the EMG in that it detects the electrical activity associated with muscle movement. The sensor detects and amplifies the small electrical voltage that is generated by the heart muscle when it contracts.

Our work used an "EKG flex/pro" sensor connected to the 2048 samples/sec ProComp Infiniti channel A. This sensor has been used in various affective computing and medical studies. e.g. (Kuli, 2007), (Kulic & Croft, 2005), (Fahimi & VaezMousavi, 2011) & (Strauss et al., 2005).

- * Channel Bandwith: 0.50Hz - 1kHz
- * Accuracy: +/- 3uV RMS, +/-5% of reading @ 25 to 30 degrees C
- * Signal Input Range: 0 - 12mV RMS
- * Signal Output Range: 0 - 600mV RMS
- * Input / Output Gain: 50
- * Sensitivity: < 0.1mV RMS
- * Input Impedance: 1,000,000 MΩ in parallel with 10F
- * Common-mode rejection ratio (CMMR): >130dB

ECG electrodes used the forearm placement (see Figure 149) which, though common, is not as accurate as the chest placement. Forearm was used because the chest placement was considered too invasive, and emotionally uncomfortable. The forearm placement (as used in many single lead electrode configurations) was made with the negative lead placed on the right forearm, while both the positive and ground leads were placed on the left forearm. Nurses were specially trained to make this placement correctly and ECG waveforms were inspected for quality before the experiment continued. Recently other studies have used this same placement eg. (Mandryk, 2005) and (Isbister, 2008, pg 219).

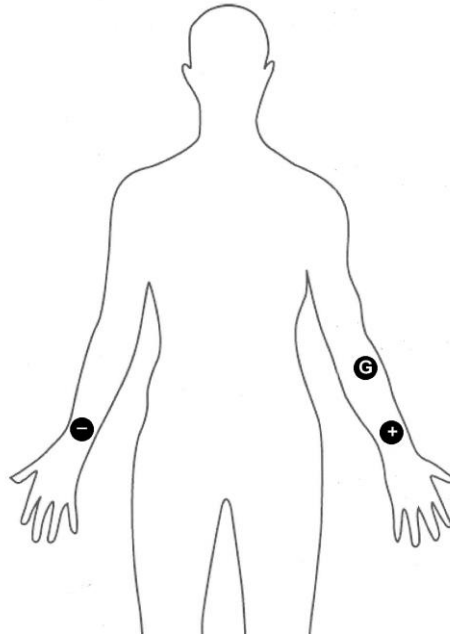

Figure 149: Electrode placement for ECG electrodes.

7.5.4. The BVP Sensor

The Blood Volume Pulse (BVP) sensor, also called photoplethysmography, bounces infra-red light against a skin surface and measures the amount of reflected light. The BVP sensor is held pressed against the palmer surface of a fingertip with an elastic strap.

The BVP sensor used in this experiment was the BVP-Flex/Pro, and it was connected to an encoder input capable of 256 samples/sec. The device was difficult to place well and required a lot of adjustments, to get the sensor to sit properly on the finger, before a good signal was obtained.

7.5.5. The GSR Sensor

GSR is a measure of the skin's ability to conduct electricity. A small electrical voltage is applied through two electrodes, usually strapped to two fingers of one hand, in order to establish an electric circuit where the subject becomes a variable resistor.

There is no safety issue with this particular current being passed throughout the body as the current is low, not high frequency, and enters and exits through the hand. If

there are any external power surges the Procomp encoder is fully optically isolated to prevent electrocution.

The GSR sensor used in our work was the SC-Flex/pro and it was connected to an encoder input capable of 256 samples/sec. The same model device has been used in various other works including (Wong, Chen, Huang, Lin & Hui, 2006), (Leng, Lin, & Zanzi, 2007), (Money, Arthur & Agius, 2008) and (Benadada, Chaffar, & Frasson, 2008).

The sensor has the following capacities:

- Input Range: 0 – 30.0 μS ;
- Accuracy: $\pm 5\%$ and $\pm 0.2 \mu\text{S}$.

The units may appear unfamiliar: the standard measurement unit for conductance is called Siemens. Skin conductance is typically measured in micro-Siemens (μS), and is convertible to micro-mhos(μm) [a mho is the inverse of an ohm] by the formula given by Equation 5.

$$G = \frac{1}{R} = \frac{I}{V}$$

Where:

R is given by Ohms law $V = IR$

I is the electric current (through the person)

V is the voltage.

Equation 5: Formula for conductivity

The GSR was fitted to the stationary hand (the one not using the SAM device) as per Figure 150.

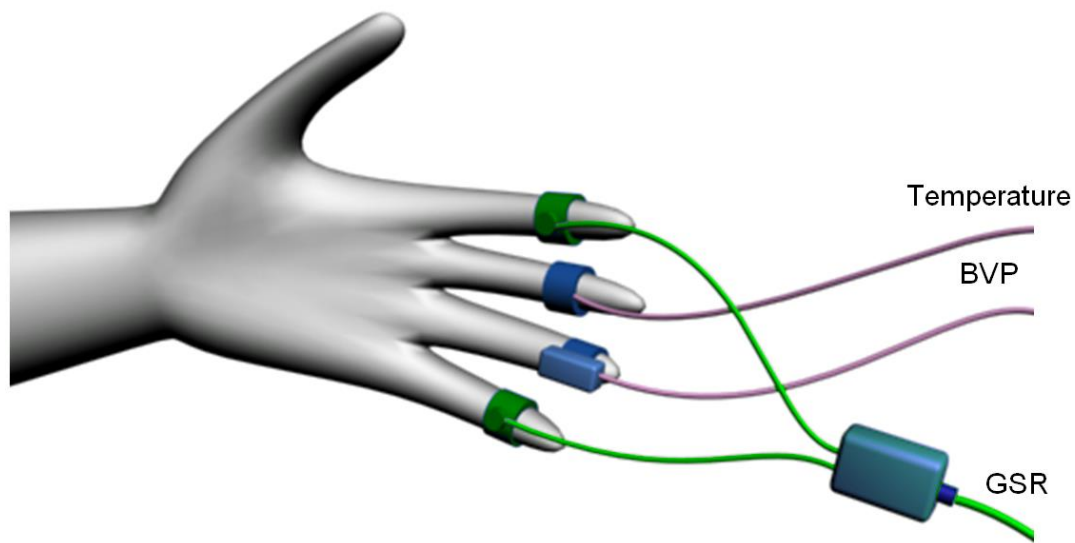

Figure 150: Location of GSR placement.

7.5.6. The Temperature Sensor

The temperature sensor, also called a thermistor, reflects changes in its temperature to changes in its resistance to electrical current. This is different to a thermometer, which typically relies on the expansion of a substance such as mercury. We attached a high quality thermistor to the middle finger.

7.5.7. The Respiration Sensor

The sensor consists mainly of a long velcro strap that is stretched around the subject's chest or abdomen. The sensor's rubber tube and circuit box should be placed in the front, as illustrated. The sensor can be placed on top of non-bulky clothing.

Note: the sensor is in part made from natural rubber which some people may be allergic to. For this reason this sensor will be placed over clothing, a spare clean t-shirt will be available for participant's wearing only bulky clothing.

Sensors are strapped around the subject's chest, just above the breasts, and at the level of the navel.

7.6 Software

There was a broad range of software used in the work, below we list the different software packages used and the tasks for which they were employed. We also developed four separate pieces of software for this work which will be explained as well.

Software used:

- Data Recording from device:
 - Procomp Infiniti, Provided by the manufacturer of the recording device;
 - Audacity, Recorded the button press noises to gauge pressure.
- Slideshow presentation:
 - Custom software “Slide Show Manager”
- Signal and Data Processing:
 - Custom written software “Experiment Workbench”;
 - Matlab:
 - Signal Processing Toolbox;
 - Wavelet Toolbox;
 - Image Processing Toolbox;
 - Neural Network Toolbox .
- Software development:
 - Microsoft C#;
 - Microsoft Visual C++;
 - Matlab;
 - Lua.
- Classification:
 - Rapid Miner;
 - Weka;
 - Matlab Neural Network Toolbox;
 - OpenSVM.
- Thesis writing and graphics:
 - Microsoft Word;
 - Mendeley;

- Custom software “Graph Maker” used for scatter plots and box and whisker charts;
- Artnatomy (used to make the muscle face diagrams in chapter 3);
- Blender (used for some of the EMG models in chapter 4);
- Make Human (used for some of the EMG models in chapter 4);
- Excel. Used for tables and some charts;
- 3Ds Max (used for models of hands etc).

The “Slide Show Manager” software developed for this work managed the task of showing slides to the participants and communicating with the SAM hardware device. It was developed in C#; using GDI+ graphics and the serial port to communicate with the SAM device.

The “Experiment Workbench” software created for the work was the main piece of software used to perform signal processing on the data. It served as a hub for importing data, processing it through internal/external routines. It was capable of delegating some tasks to Matlab where needed. The entire application was scriptable via Lua so that all the work done could be automatically reproduced or recovered. The software was also capable of graphing the signals as we worked with them. A summary of the files contained in the “Experiment Workbench” project. The system was designed to use a minimum of 4GB ram, but 24GB is recommended.

Table 10: Source Code for the “Experiment Workbench” Project.

Language	files	comments	Lines of code
C#	582	42,077	148,580
MATLAB	889	19,334	38,536
C++	25	655	5,288
C	14	811	2,279
C/C++ Header	33	1,036	1,652
Lua	27	319	1,567
DOS Batch	5	0	83
make	1	10	25
SUM:	1,576	64,242	198,010

The “Graph Maker” software created (using C#) for this work was responsible for the box and whisker charts. It also produced the confusion matrices and some of the scatter plots. The last piece of software developed for this work was the firmware for the SAM device. This was written in standard C.

7.7 Conclusion

In this chapter we have covered our experimental setup. It is often mentioned in literature that emotion elicitation experiments lack necessary detail in the room preparation and stimulus procedure (Angelica et al., 2010). We hope we have addressed this need.

The experimental method we have prepared focuses on two conflicting objectives:

- Having a emotionally neutral environment which allows the IAPS slide stimulus to be the prevalent emotive force during the experiment;
- Quality of collected data in terms of signal fidelity.

To meet these conflicting requirements, we have forgone the use of any invasive sensors, which would have produced a better signal quality. We have chosen ECG sensor placements on the arms, rather than the chest, as a chest placement may have been a source of discomfort. Additionally we have used an ordinary appearing room, as opposed to a metal cage for full RF shielding.

We have a procedure that is very safe, and a workplace that is highly organised and well rehearsed prior to starting work. We also demonstrated how we went about the ethical treatment of our subjects.

So far we have not discussed our self assessment task, as we felt our innovations in regards to this exercise warranted a dedicated chapter, which follows.

8.0 Feedback via a Hardware SAM Implementation

“There is a computer disease that anybody who works with computers knows about. It's a very serious disease and it interferes completely with the work. The trouble with computers is that you 'play' with them!”

-Richard Feynman (1918 – 1988)

In this chapter we discuss our work with implementing the Self Assessment Manikin (SAM) for use in a PPR environment. The end result of this portion of the work was a (published) hardware implementation (Creemers & Hingston, 2010). This device is made freely available to other researchers via complete hardware, firmware and software source materials, see appendix 14.10.

The SAM scale allows a person to make a “self report” of their emotional state. The SAM was originally created by Bradley and Lang (1994) and there have been several variants of the SAM used in various experiments, as shown in Table 11. The classical SAM, shown in Figure 151, uses three rating scales “Arousal”, “Valence” and “Dominance” as per the three factors found in the semantic differential research by Osgood et al., (1957).

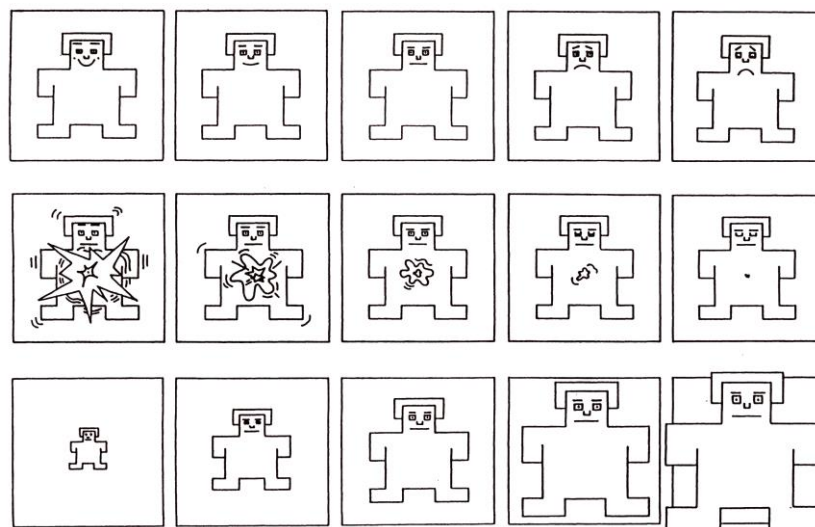

Figure 151: Self Assessment Manikin.

The top row is used to rate Valence, the second Arousal and the third Dominance.

Reviewing key points discussed in section 3.5.2, the SAM offers the following advantages:

- It is cross cultural (Morris, Bradley & Wei, 1994);
- It is completed in 3-15 seconds (Verbal techniques take much longer);
- It avoids individual subjective bias of words like “happy “ and “sad”;
- The device produces valid results regardless of age (Backs et al., 2005), including children (Lang, 1985);
- It is established and well understood.

Table 11: Various adaptations of the Self Assessment Manikin (SAM)

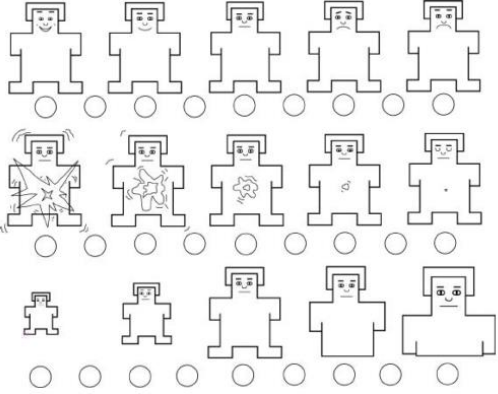
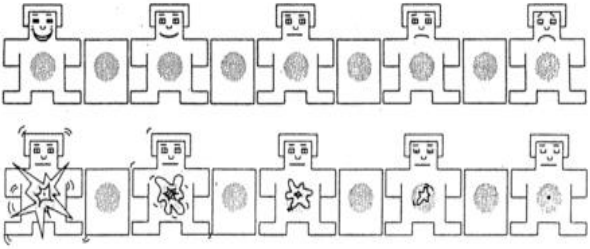
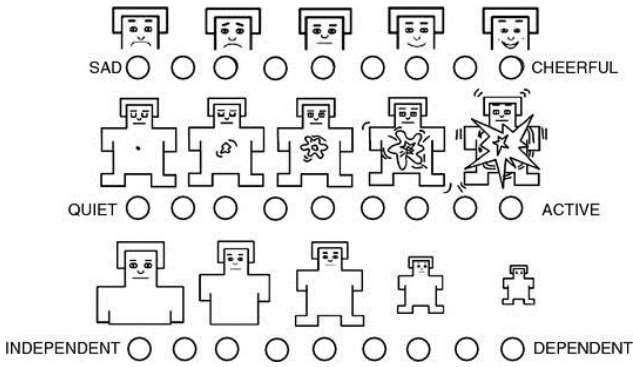
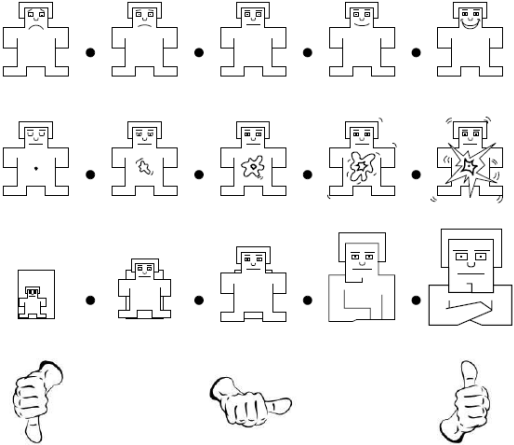
<p style="text-align: center;">Alternative Dominance Images</p> <p>(Morris & Burke, 1995) (Tsonos & Kouroupetoglou, 2007)</p> 	<p style="text-align: center;">Only Valence and Arousal</p> <p>(Zimmermann, Guttormsen, Danuser, & Gomez, 2003) (Khan, 2008) (Neerinx & Streefkerk, 2003)</p> 
<p style="text-align: center;">Alternative Valence pictures</p> <p>(Schifferstein, Talke, & Oudshoorn, 2011)</p> 	<p style="text-align: center;">Additional axis "liking"</p> <p>(Koelstra et al., 2011)</p> 

8.1 Requirements Analysis

For the purposes of this research, several criteria were defined to represent our experimental needs for Self Assessment Manikin (SAM) feedback. (These criteria are also broadly representative of many other researchers who utilise the SAM, e.g. (Surakka & Anttonen, 2005), (Swindells et al., 2007) & (Bradley et al, 2001).

1. The SAM should be simple to use, have minimal emotional impact on the user and present minimal distraction from the experiment;
2. User interaction events with the SAM should be recorded with approximately 10ms accuracy (so as to be sampled faster than the screen is refreshed);
3. SAM events must be synchronised with any physiological recordings made during the experiment (for purposes of artefact removal);
4. Allow the user to provide feedback and interact with the device in a manner that minimises muscular action as this may introduce artefacts into the physiological signal being recorded.

The fourth criterion is not straightforward. It is known that passive sensors recording electrical events in the body are easily overwhelmed by large muscle movement. Typical examples of such sensors include the electrocardiogram (ECG) and electroencephalography (EEG). Both these measurements are often used in experiments involving SAM feedback.

An ECG signal is typically detected at a magnitude below 1mV with the signal in the frequency range 1Hz to 70Hz. Electromyographic (EMG) output from muscle movement lies between 7Hz to 20Hz in the frequency spectrum, with magnitude as low as 50 μ V for small muscles and up to 30mV for the larger muscles. The presence of EMG noise is highly detrimental to the ECG signal (Clifford, 2006) and the best solution is to keep the participant's larger muscles still.

As the ECG is often recorded during experiments using a SAM and the signal is very prone to EMG artefacts, in this work we will use ECG quality (as recorded from a sitting position) as a method to determine if a SAM implementation can achieve the fourth criterion, of minimising muscular action.

With the goal of meeting all the experimental criteria, we built a hardware device to record SAM interaction. This device is shown in Figure 152.

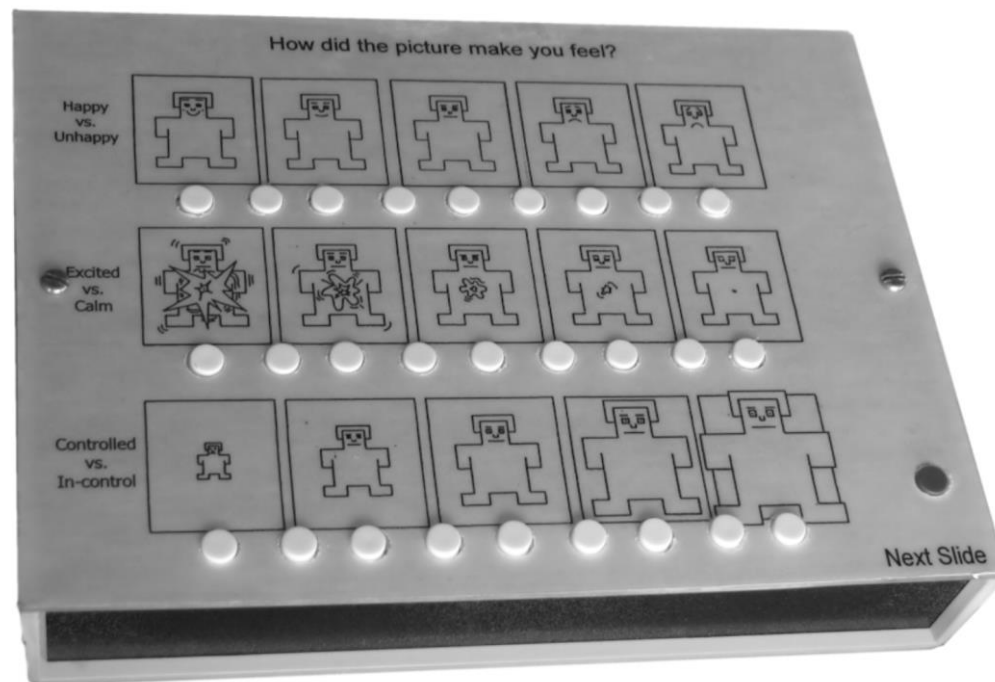

Figure 152: The Hardware SAM developed for this experiment.

This solution was discovered after investigating three existing SAM interface setups and trialing a novel (but ultimately unsuccessful) PDA solution.

The following common setups were examined with respect to the four criteria defined for a successful SAM interface:

- SAM on printed answer sheets;
- SAM as PC Software;
- SAM on a Personal Digital Assistant (PDA/tablet);
- SAM as a customised hardware device.

There do exist other means of using the SAM, such as Kuroda, Izumikawa and Kouketsu (2009) who had participants orally call out codes from a SAM print out attached to the steering wheel of a vehicle simulator.

8.2 SAM on printed answer sheets

The pencil and paper version of SAM (Lang et al, 2001) satisfies only the first of our four criteria. However it is potentially the best placed to address the first criterion. People are used to filling out surveys using pencil and it is thus considered to have a minimal emotional impact.

It should also be noted that this system is more reliable than its technological counterparts, however, it is possible that the data may suffer from human error during data entry when the answer sheets are tabulated.

Muscle movement of the user filling in a SAM answer sheet often involves the use of the forearm (activation of large muscles) and thus signal quality is degraded, as shown in Figure 153.

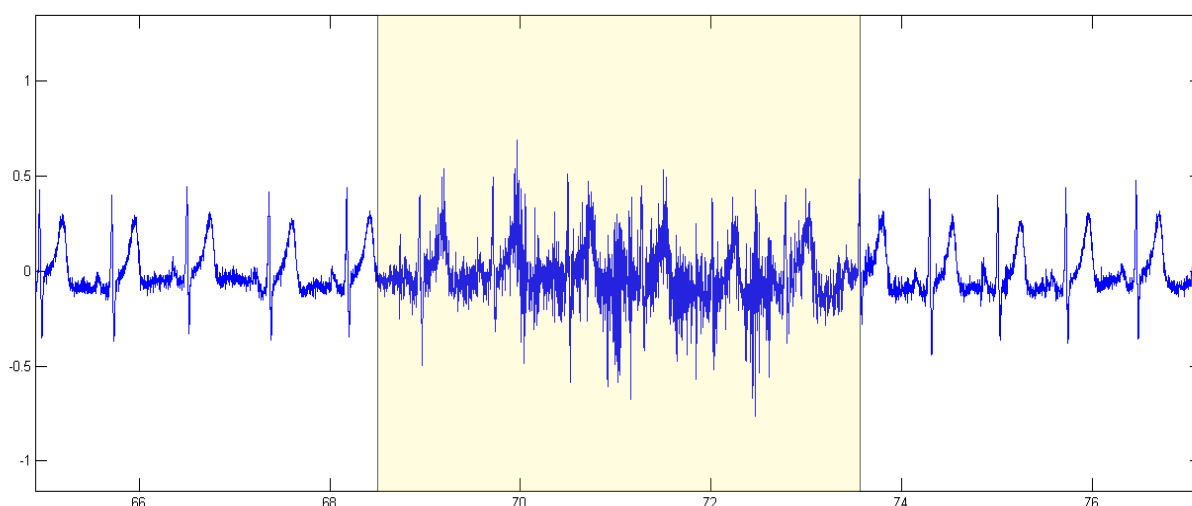

Figure 153: Noise in ECG Signal produced while using SAM on a hardware device.

[The shaded region indicates SAM was in use].

With the increasing popularity and ubiquity of computing, many researchers now prefer a software setup of the Self Assessment Manikin, e.g. (Choppin, 2000) and (Swindells et al., 2007), as it allows for a potentially easier workflow in experiment tasks.

8.3 SAM as PC Software

The SAM can be implemented in software and allow the user to provide feedback via a PC, using the dual input of keyboard and mouse. There exist several PC Input arrangements to achieve criterion 2. These include:

- SAM using keyboard / mouse input;
 - via multiple monitor computer using one display for stimulus, one for the SAM ;
 - via standalone application (Koelstra et al., 2011);
 - via a notebook (Oliveira, Fonseca, Teixeira & Simões, 2005).
- SAM on a touch screen (Morris & Burke, 1995).

A common solution to address the first three criteria is to use a computer to display the SAM and take participant feedback. In this way the feedback is simple to use, and can be accurately recorded in synchronisation with other data acquisition hardware. There are many variations on this procedure, but in essence, the user has a screen with a SAM displayed and a keyboard (and/or a mouse) to fill out the SAM with. This is shown graphically in Figure 154.

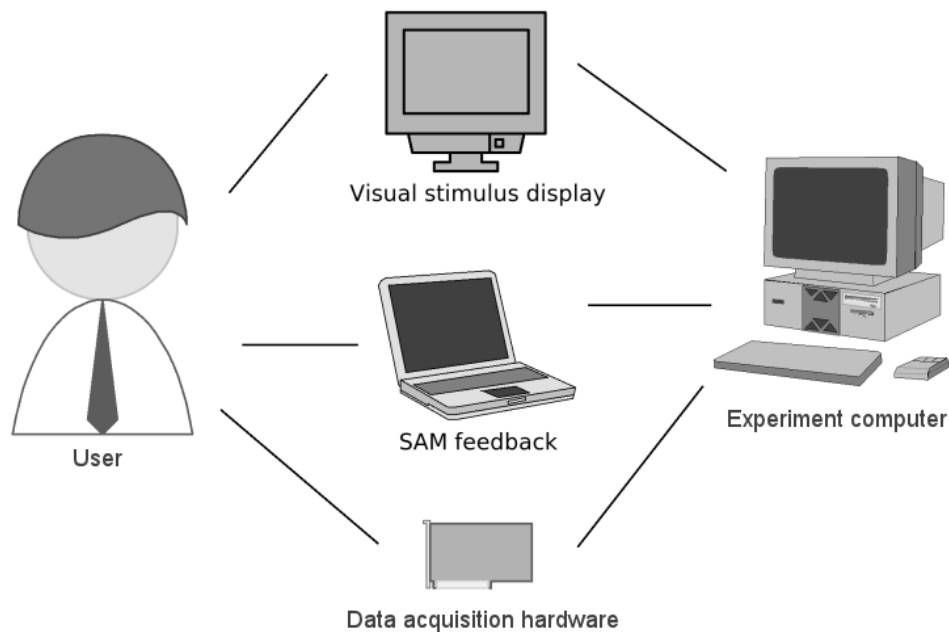

Figure 154: A generic PC controlled SAM experiment

One of the most widespread, technological adaptations of the SAM involves the use of a touch screen display. This is an extension of the dual input application but using a touch screen for user input rather than a mouse. This is a much more achievable goal than attempting to have a computer recognise two independent mice.

The touch screen does not address the fourth criterion, as user movement is greatly increased during input. Specifically the entire forearm must move for the user to select an input option on the opposite edge of the screen, and traveling the arm up and down the screen requires bicep movement. This involves usage of large muscles, and the result is a greatly degraded signal. Another drawback is that the user is brought into close contact with an LCD device that emits a broad range of RF interference, which may affect the instrumentation.

The most accessible software implementation for SAM-based experiments to date is the Self-Assessment-Manikin Scales feature of the PXLab software (Irtel, 2007). This (open source) software offers several variations of the SAM and the ability to use the SAM to evaluate picture, audio and textual stimuli.

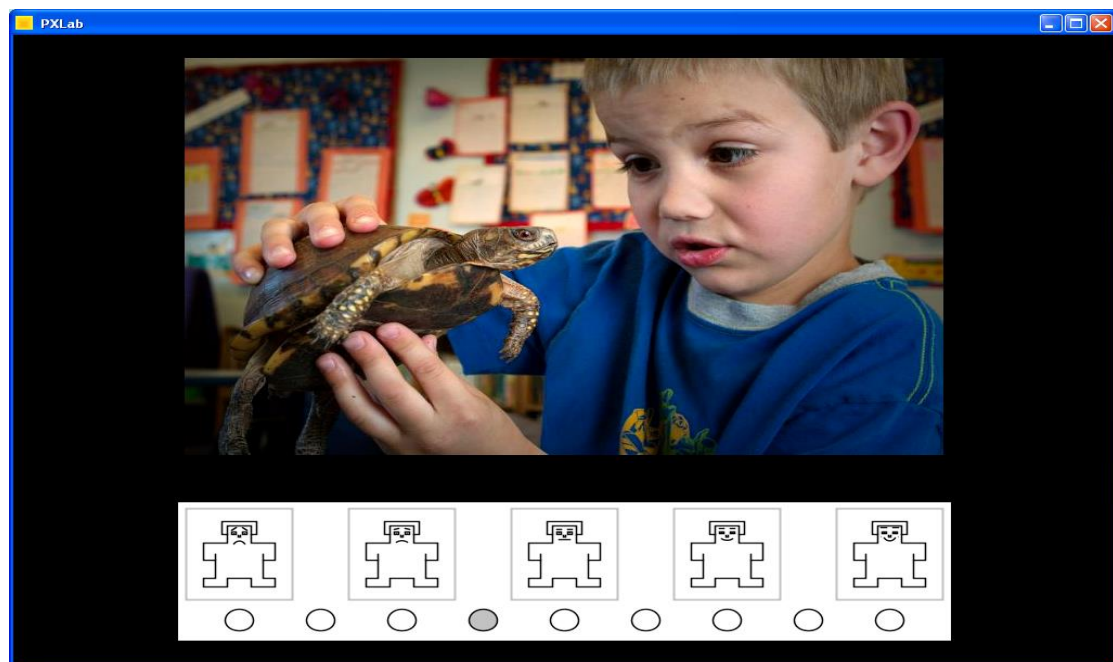

Figure 155: PXLab software (Irtel, 2007)

As with most standalone application implementations of the SAM, PXLab offers exact timing of all events. User feedback is accomplished with mouse and keyboard interaction.

Other researchers have implemented software which allows for the SAM to be used on a dedicated evaluation computer. The Master's thesis of Antoine Choppin (Choppin, 2000) uses the software shown in Figure 156. The software, though functional, does provide a potential emotional stimulus in its own presentation by virtue of its appearance and the graphical stylisation of the operating system.

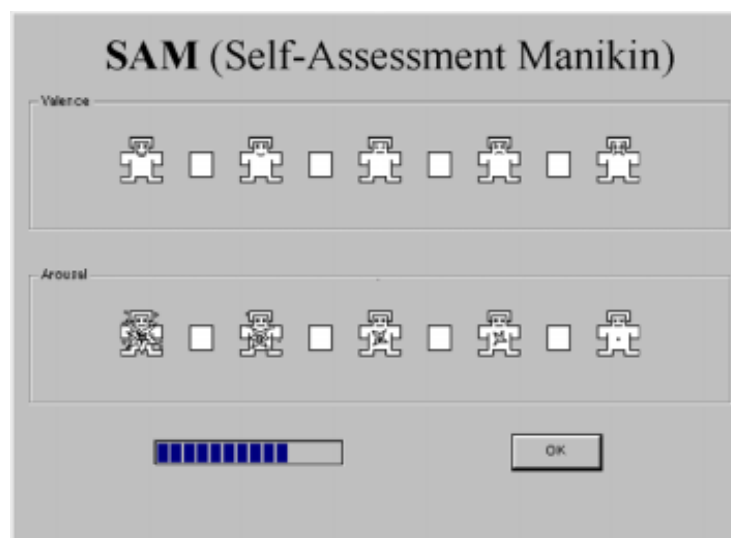

Figure 156: Self Assessment Manikin Software [as used by (Choppin, 2000)]

Using a computer has some strong connotations associated with it. Those unfamiliar with computers may feel apprehensive, anxious or afraid (Meier, 1985). Moreover the choice of computer manufacturer (brand) will create "goal directed action". That is the type of computer the user is placed in front of will set the tone for the kind of behaviour expected of them. A study of user behaviour under the influence of Apple and IBM branding (Fitzsimons, 2008) showed some interesting physiological effects created by modern computer branding. The study asked participants to find unusual uses for a brick. Participants (n=314) were split into two groups primed with Apple (n=219) and IBM branding (n=122). The study found the Apple primed participants to be more creative in both measures used; "number of uses" (Glover & Gary, 1976) and "judge panel ratings" (Silvia & Phillips, 2004). Results are shown in Figure 157.

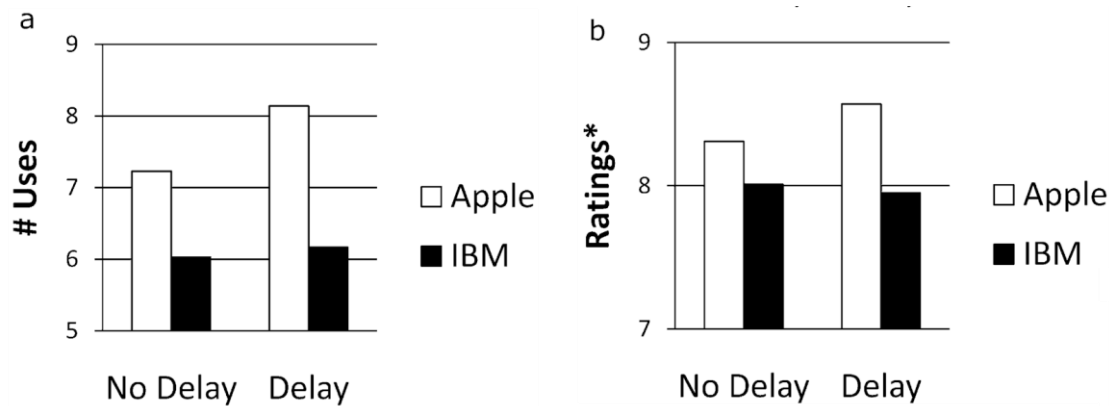

Figure 157: Apple vs. IBM branding, effect on creativity (Fitzsimons, 2008). Results given for experiments conducted with and without a five minute delay between the priming stimulus and the creativity task.

Fitzsimons claims the goal directed action of “being creative” was enabled via the activation of linked means to that goal (Shah & Kruglanski, 2002), the linked means for the creativity goal being given as “seek unusual associates” and “inhibit usual associates” (Sassenberga & Moskowitzb, 2005).

Given evidence to suggest Apple and IBM branding changes the way people may think, and the general observation of brand loyalty eliciting emotions, it would seem likely that a computer system brand may have significant effect on the participants in the experiment.

Whatever the brand, a separate computer running a form of SAM software may also create a cluttered experimental environment. Cluttering of computers increases electrical interference, noise levels, participant intimidation and adds many technical challenges in terms of synchronising data. A typical example of the kind of cluttering possible in an experimental setup is Swindells et al (2007): a photo of the setup is shown in Figure 158. However it should be noted that Swindells was exploring haptic devices using the SAM for affective evaluation; this experiment is not negatively effected by the clutter in the same manner as other types of experiments are.



Figure 158: Cluttered experimental setup. (Swindells et al., 2007)

Having multiple devices for a user to interact with can also cause extra motion as the participant swaps from one device to another. This in turn can create EMG interference, especially if the devices are poorly placed.

A single device showing both rating and stimulus screens (e.g. PXLab) is preferable with regards to minimizing EMG interference. With this type of application EMG interference can be minor as the user is only using the mouse and not changing arm position between the keyboard and the mouse. A typical sample of this kind of noise is shown in Figure 159.

A practical problem exists with this procedure as the participant will tend to keep one hand on the mouse instead of returning to a fully relaxed position, and hence a small amount of EMG interference can typically be observed during periods of the experiment where the signal would typically be cleaner under other SAM implementations.

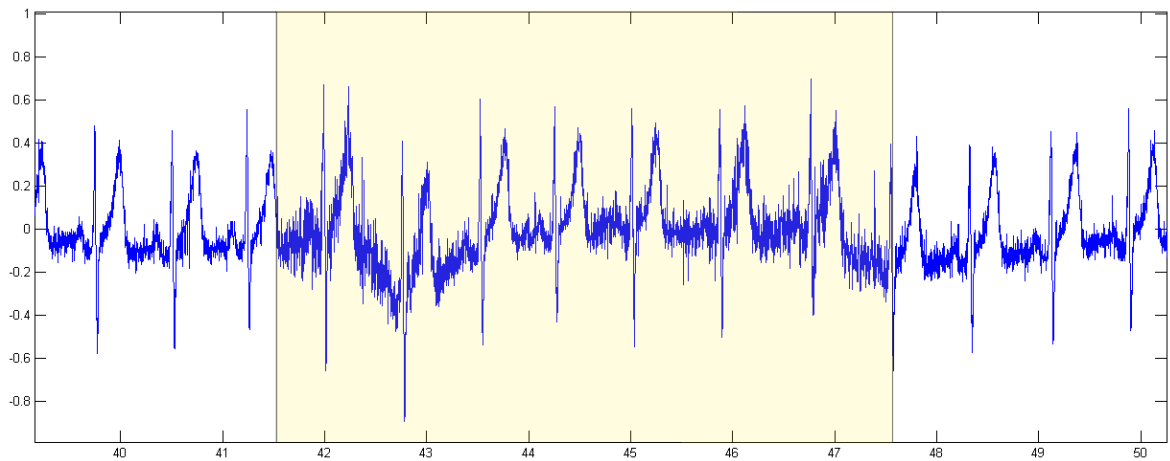

Figure 159: Noise in ECG Signal produced while using PXLab. Shaded region indicates SAM was in use.

This constant background noise can be present while the user is receiving stimuli and to many researchers this is the most important time to have a clean signal. If constant evaluation of user signals is needed, this may be a very good solution as the noise levels, though present, are reasonably low.

8.4 SAM on a Personal Digital Assistant (PDA/tablet)

The software SAM apparatus discussed so far does not present strong solutions to criteria 1 and 4. That is, they are (possibly) a distraction for the user and do not optimise physiological signal quality.

We made a preliminary, but ultimately unsuccessful attempt to computerise the SAM in a manner that solves criterion 4 (minimising muscle movement). This involved the novel use of a PDA to present a SAM rating screen and receive user feedback via a stylus. See Fig 160.

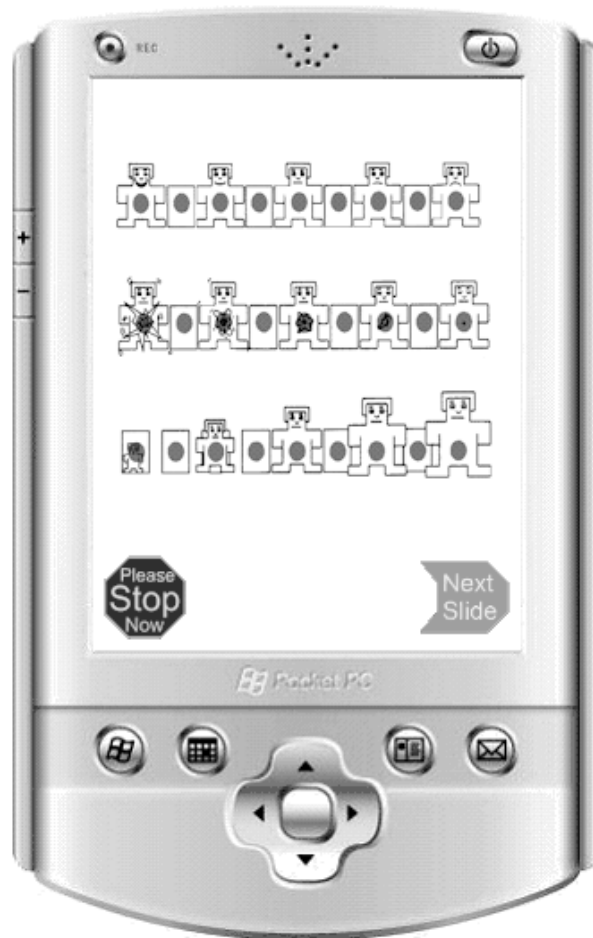

Fig 160: Our SAM implementation on a PDA

The use of a PDA for SAM feedback is not common, but has been used in experiments such as (Neerinx & Streefkerk, 2003) who performed an experiment involving emotional feedback from video stimulus using both a IPAQ PDA and a regular laptop. They found some differences with the way participants trusted the devices, see Figure 161 and also found differences in mean SAM scores, concluding:

“Task performance with the mobile device resulted in a lower Valence score than with the laptop. In other words, users experienced a more negative emotion with the mobile device. Similar to trust, this effect might be attributed to the decreased performance.”

These findings mean that the device may not perform well in terms of not affecting the participant emotionally.

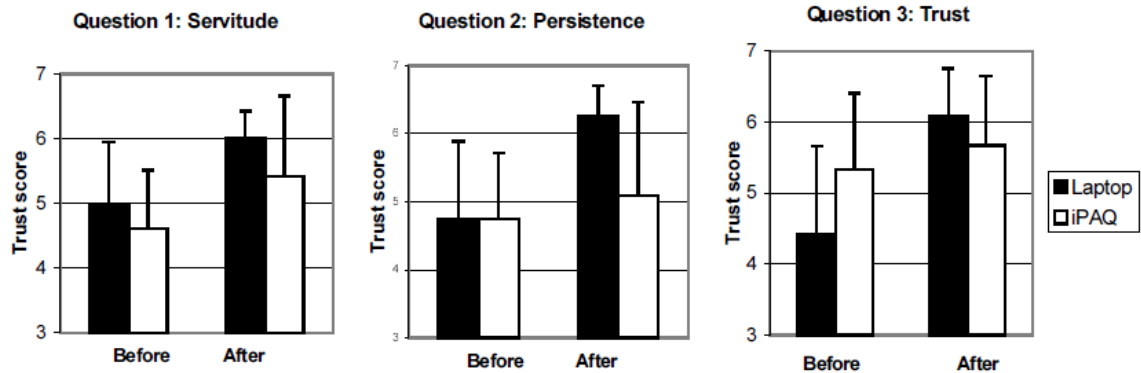

Figure 161: (Neerinx & Streefkerk, 2003) Measurement of user trust in a device both before and after an experimental task.

The rationale for using the PDA as an input device was to keep the natural feel of a pen and paper style interaction with minimised muscle movement. Muscle movement is greatly reduced because the fingers move to fill out the SAM and not the arm. If the participant is seated at a table and is free to place the PDA in a centralised position comfortable to them, then a survey can be completed with less major muscle movement than any other implementation investigated here. A typical sample of the signal produced while using a well-positioned PDA for SAM feedback, shown in Figure 162, has a noticeably reduced noise level over the conventional PC readings shown in Figure 159.

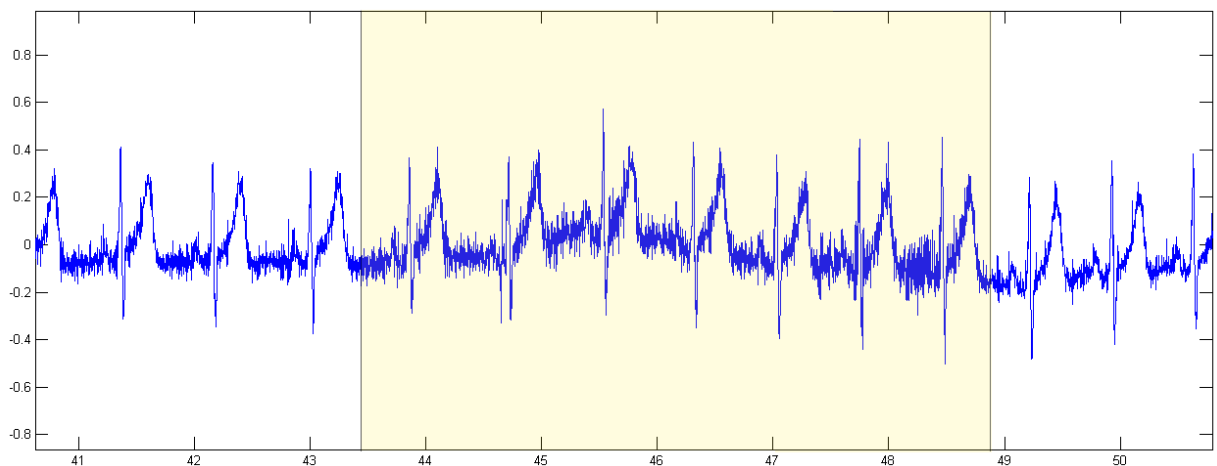

Figure 162 : Noise in ECG Signal produced while using SAM on a PDA (user is coached). Shaded region indicates SAM was in use.

The signal quality, however, is dependent on how well the participant has been coached to utilise the PDA and how easily the ergonomics of the environment allow the participant to go from a relaxed state to using the PDA. If the user is poorly coached then the result can easily be as bad as the other methods. Figure 163 shows a (typical) example of noise levels in an experiment where the user was not coached or supervised. When this is compared to Figure 162 it is evident that a greater portion of the “in use” recording has resulted from noise.

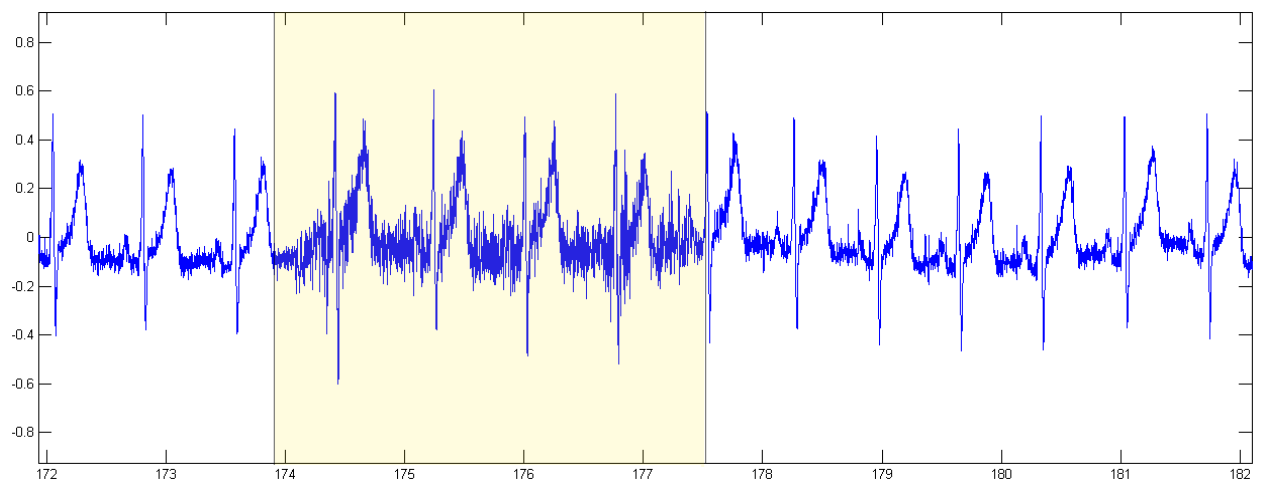

Figure 163: Noise in ECG Signal produced while using SAM on a PDA (user is not coached). Shaded region indicates SAM was in use.

Unfortunately two aspects of the generic PDA device (at the time) made this kind of interaction unsuitable:

- Lack of resolution;
- Real-time connectivity problems.

Resolution limitations of the PDA make some facial details of the pictures too difficult to recognise – see Figure 164. Newer high-end PDA’s with VGA resolutions come a long way to fixing this but still lack the detail to show SAM figures as rendered for pen and paper use (Lang et al., 2001)

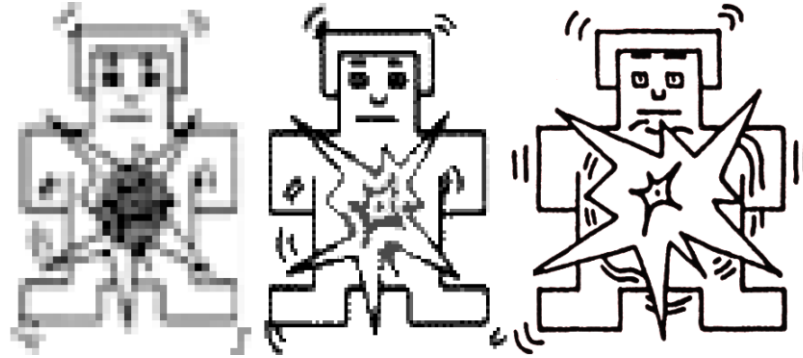

Figure 164 SAM character from: PDA (left), VGA (middle), paper (Right).

To achieve criterion 3 the PDA software must communicate with the PC running the experiment. However it is technologically prohibitive for our PDA software to establish a useful connection with the experiment PC. The most flexible TCP connection available to many PDA's is the WiFi connection, however use of WiFi around ECG systems is not permitted in many countries (as discussed in section 7.4.2). There is also an IrDA port that could be utilised but this was technically unfeasible, as an API for WinCE programs to interface with this port was not available at the time the experiment was conducted.

8.5 SAM as a Customised Hardware Device

In an attempt to meet the four performance criteria defined in 8.1, we created our own hardware solution for recording SAM feedback. In this section we detail this device in terms of its technical capacity and its effect on signal quality.

8.5.1. User Interface

The device utilised a white translucent panel with the SAM printed on it and a series of buttons under each picture to allow for user input. As the user presses a button, the device provides feedback by illuminating the picture selected with a diffuse blue light which filters through the translucent screen on the front panel to clearly highlight the selected choice in a non-distracting manner.

Two additional buttons were provided on the device. These buttons can be given any label, but were for the purposes of this experiment given the labels "Next Slide" and

“Stop”. The (less common) procedure of having the user initiate the next IAPS slide has been shown to work successfully in experiments by Sloan et al., (1997) where the space bar on a keyboard was used for this purpose.

8.5.2. Technical Capabilities

The device is accessed via a software API and can be utilised by the software running the experiment in real time. The unit is equipped with a Piezo transducer capable of producing beeps of varying frequency, the volume of which can be set via a concealed volume knob accessible by insertion of a small screwdriver.

A microphone is also present in the device and can be used to record the intensity of keystrokes (more vigorous key strokes produce a more audible clack inside the device). The microphone is intentionally not sensitive enough to make any vocal recordings so as to be amenable when obtaining ethics clearance for experimentation. Due to some processing issues this data was recorded but never used. The unit is further equipped with a relay capable of providing two levels of resistance to an isolated port on the device. This relay, which can be controlled by the API, is used to fingerprint recordings taken via physiological recording devices so that data streams can be accurately synchronised with user activity during data analysis. An example is shown in Figure 165. The signal having been transmitted by the SAM hardware and recorded by the physiological recording device can be used as a synchronisation point.

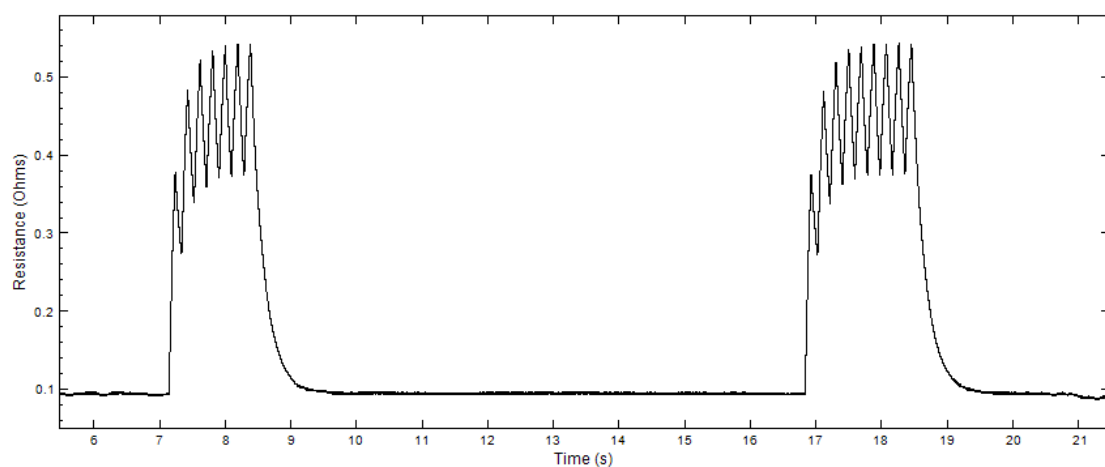

Figure 165: Hardware Sync Signal. First Sequence has 7 peaks, and the second sequence 9 peaks. Giving this recording the unique ID “79”.

8.5.3. Signal quality

The hardware version of the SAM showed a very clean “at rest” signal and produced an acceptable level of noise while in use. The “in use” noise is generally higher than the PDA solution shown here but is not so high as to make the system unusable.

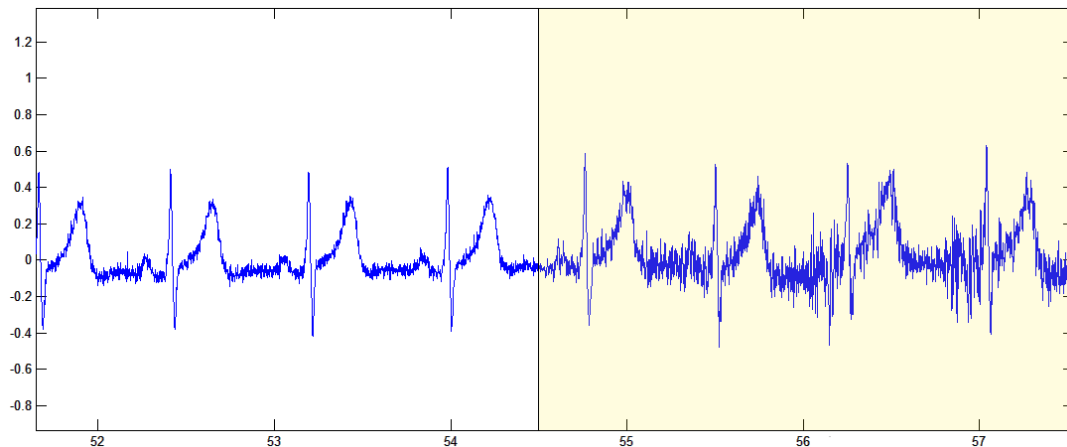

Figure 166: Noise in ECG Signal produced while using SAM on a hardware device. Shaded region indicates SAM was in use.

Typical results for noise levels are shown in Figure 166. The noise is mainly due to a sliding motion of the forearm. A brief, sub heartbeat, distortion related to the action of pushing the button is typically present. This is perhaps due to the device not being ergonomically refined, coupled with the small movement of the buttons on the device.

8.5.4. Technical Challenges

Most keypads work by scanning the keys to determine if any new closed circuit is formed by a key being depressed. This scanning causes various electrical tracks and wires to be charged and then discharged every time the scan moves to another key. This design, by its very nature, induces an electrical interference, and would be detrimental to our signal quality concerns. To avoid this scanning artefact we utilised a resistor ladder to vary the voltage into one of the microcontroller Analog to Digital Converters (ADC) based on which button is pressed. Three ladders were used, one for each row of nine SAM buttons. An example of these ladders is shown in Figure 167.

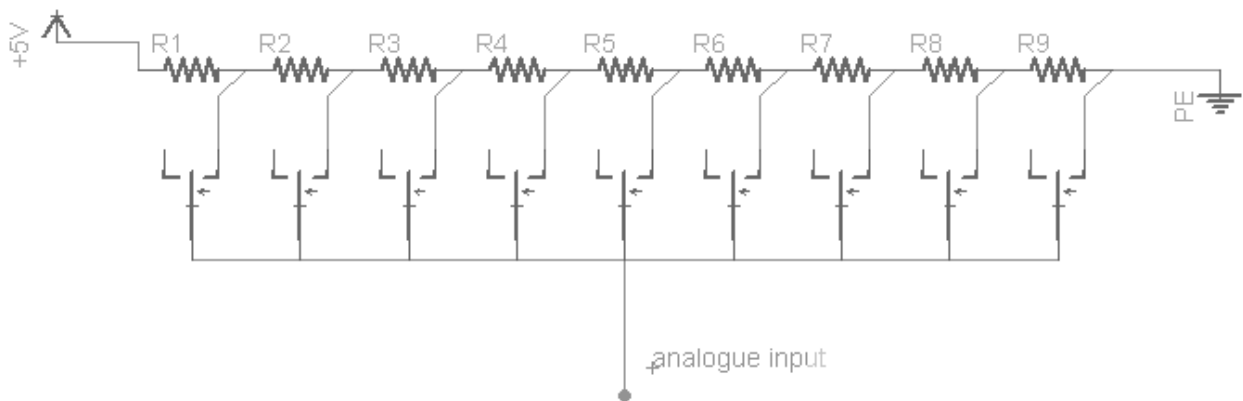

Figure 167: Resistor Ladder used in the hardware SAM.

A full circuit diagram and other details concerning the hardware device are given in Appendix 14.10.

8.6 Conclusion

Our goals in creating a hardware SAM were to obtain a balanced input device. Our implementation is simple to use, and has a minimal emotional impact on the user. All events were recorded and synchronised with physiological recordings made during the experiment.

Used correctly the device allows the user to provide feedback in a manner that minimises muscular action likely to introduce artifacts into the physiological signal being recorded.

The Hardware SAM we created provides many experimentally beneficial features, however the solution is not necessarily suitable for other applications. It is not usable in fMRI studies as it contains electrical components. We summarised the five types of SAM examined in this section in Figure 168.

	Paper	PDA	2 nd Notebook	Software	Hardware
Usability	😊	😊	😊	😊	😊
Synchronised with data acquisition	😞	😊	😊	😊	😊
Detail of SAM pictures	😊	😞	😊	😊	😊
User distraction	😊	😊	😊	😊	😊
User muscle action	😞	😊	😊	😊	😊
Level of interaction	😞	😊	😊	😊	😊
Experimental flexibility	😞	😊	😊	😊	😊
Support for different SAM models	😊	😊	😊	😊	😊

Figure 168: Comparison of SAM feedback Devices.

The validity of this device as a feedback apparatus is inherited directly from the demonstrated validity of the Pen and Paper SAM (Lang et al, 2001) as is the paper version with buttons instead of check boxes.

The device's usefulness is apparent in that it provides all the benefits of a software device (synchronised data, easy to perform task), without the emotional connotations of a computer or PDA. The EMG/ECG recordings that are often collected at the same time are improved over other alternatives in that a minimum of motion is needed to complete the feedback. This includes eliminating:

- Navigational key presses;
- Navigational mouse movements;
- Pen/stylus movements.

9.0 Signal Processing and Feature Extraction

“Eureka”

- Archimedes

In this chapter we document all our signal processing and feature extraction steps for the six physiological sensors we used.

A signal collected from any sensor is considered “raw data”. It is programmatically or even visually difficult to examine the signal and gain a good understanding of what is happening. In order to begin the process of signal analysis a necessary first step involves cleaning up the collected signal. This cleaning up phase is designed to process the collected data so that it more closely resembles the signal that the sensor is observing, whilst minimising any effects by the sensor and the transmission medium. This is usually achieved by using a series of filters (processes that modify a signal) to:

- Remove any noise present in the data;
- Detect events where recording equipment produced an error or artefact;
- Correct for issues in recording such as baseline drift.

After a clean signal is produced, a process of feature detection is used to extract useful information out of the signal. This may involve keeping only parts of the signal that are of a specific amplitude or frequency. It could involve other techniques that transform the signal to produce a result that has strong correlations with a phenomenon under investigation.

9.1 ECG Signal

The ECG signal is the appearance of myocardium¹ electrical activity on the body surface. This signal appears as an almost periodic occurrence of the ECG basic waveform (Dubin, 2000), see Figure 169.

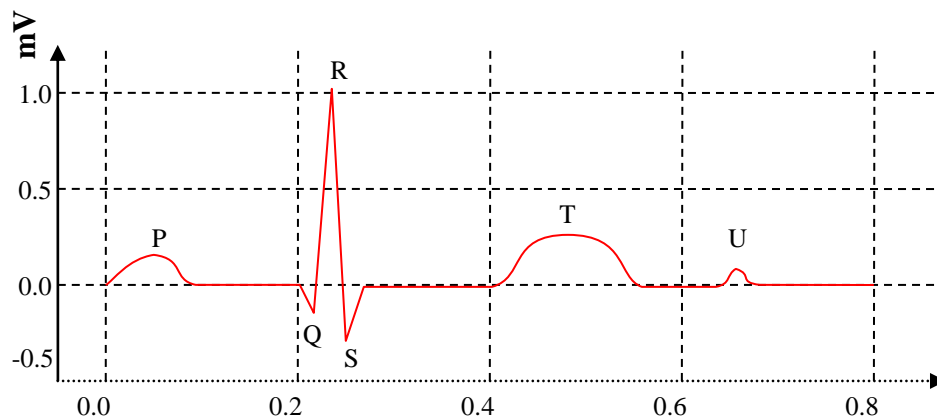

Figure 169 The Basic ECG waveform showing locations of the P, Q, R, S, T & U Components

As discussed in section 3.3.9, this waveform can be analysed in terms of the P, Q, R, S, T and U waves which are referred to as the P-wave, QRS Complex, T-wave and the U-wave. In this section we present our methodology for filtering and preparing the ECG data. We then document our method for detection of the different features based on the P,Q,R,S,T & U components. Finally we present our algorithms for feature detection and creation of person invariant training data.

9.1.1. Overview of Filtering the ECG Signal

Filtering of ECG is necessary to remove the noise which enters almost all ECG recordings. The ‘quality’ of this filtering is given by the extent to which the filtered signal is a smooth (and undistorted) line that maps directly to the activity of the heart. This task is non-trivial because the noise can be at similar frequencies, and with similar morphology, to the signals being extracted. A summary of the signals features

¹ The large central, muscular, layer of the heart wall.

and noise components of an ECG is shown in Figure 171. This image is a superimposed version of the graphs presented by Thakor, Webster and Tompkins (1984).

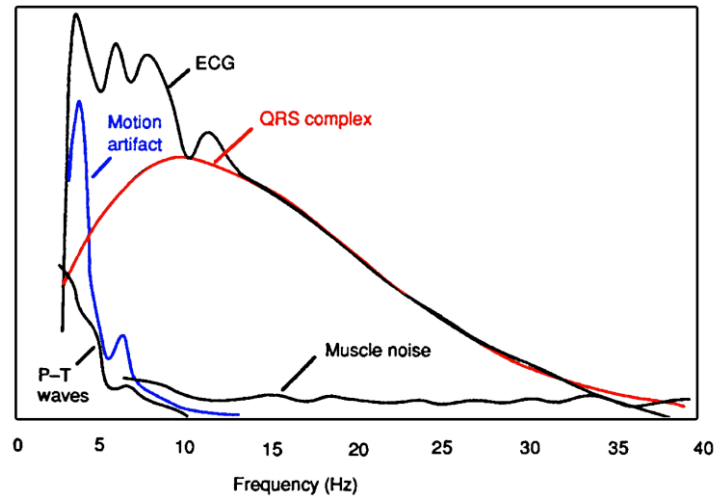

Figure 170: Components of the ECG Spectrum (Thakor, 1988)

We will discuss in point form the Typical ECG contaminants based on Friesen et al., (1990) and the extent of their presence in our data:

- Power line interference:
A 50Hz (or 60 Hz in some parts of the world e.g. USA or Canada) sine wave inducted by utility lines into the ECG sensors and wiring. This is evident in our data and discussed in detail later in the next section (9.1.2).
- Patient–electrode motion artefacts:
The electrode is jolted or moved and the contact area on the skin is altered. The resulting variations in the impedance usually results in rapid and continuous baseline jumps (see Figure 171 b) or complete saturation for up to half a second (see Figure 171 a).

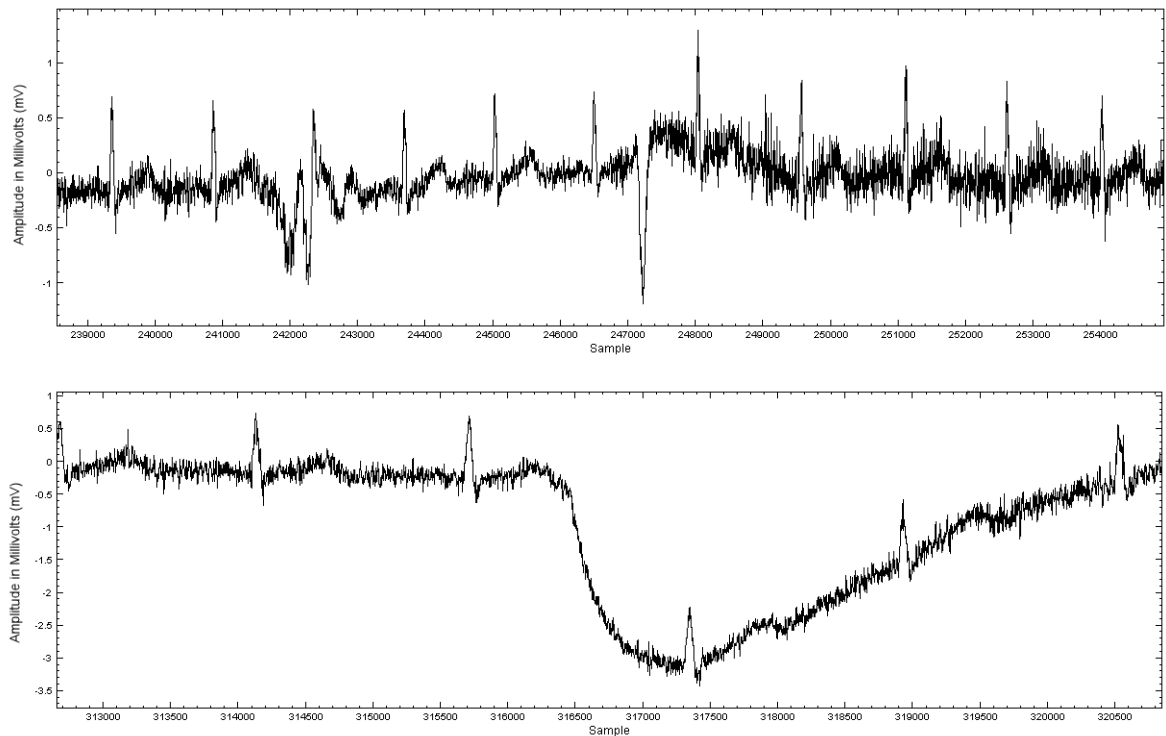

Figure 171: Examples of electrode motion artefacts in our experiment. (a) Electrode drop out followed by saturation of signal by EMG (muscle activity) noise. (b), rapid baseline drift.

- **Baseline drift:**

Usually caused by respiration, this is a low frequency wobble of the signal. The signal is otherwise normal if this low frequency component is removed. An example of baseline drift is shown in Figure 172.

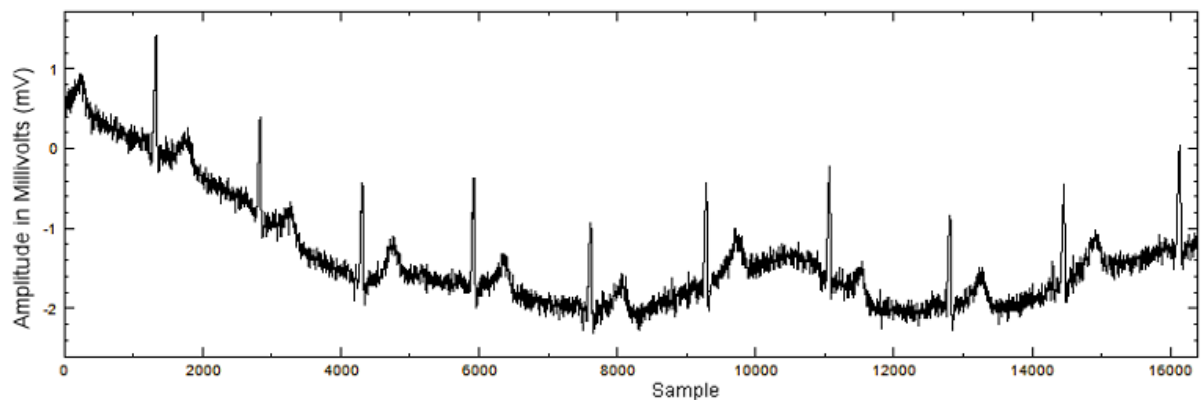

Figure 172: Baseline drift in the ECG signal.

- Electrosurgical noise:

The noise generated by other medical equipment present in patient care environments. Generally not applicable to the type of laboratory we used. Care was taken to ensure this was not present in this work, and other computers and devices in the room were tested (by cross examining spectrograms on recordings of a generated signal, with and without device operation) to ensure they produced no interference to our experiment.

- Data collecting device noise:

This is caused by the data collection hardware, often includes signal saturation and “zeroing in” artefacts; in our hardware this was quite rare (with the exception of data collected shortly after electrode connections were made), we were able to find some rare instances such as shown in Figure 173.

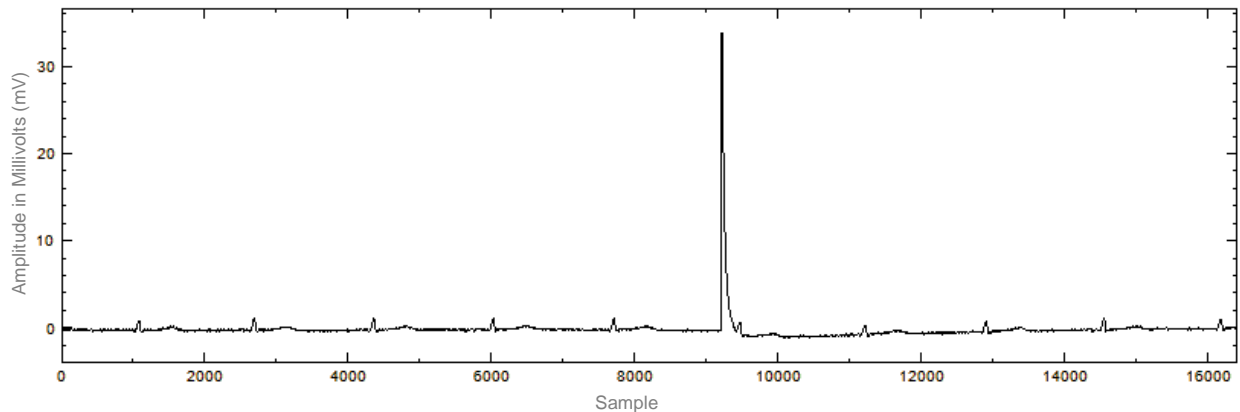

Figure 173: Device noise, A filtering artefact in response to impulse noise.

- Quantisation noise and aliasing;

Quantisation noise is negligible as the signal is sampled well above the applicable Nyquist frequency and the encoder uses a 14bit Analogue to Digital Converter with a Least Significant Bit (LSB) Magnitude of $207\mu\text{V}$. Anti-aliasing is done in the encoder hardware with a 5th order Butterworth filter for a typical result of 30db Alias rejection.

- Electromyographic (EMG) noise:
This is a prevalent noise caused by electrical impulses generated when a person moves. Whilst this noise is minimal when the subject is still, moving an arm or a leg can result in more noise than the signal being received.
- Electrode pop or contact noise:
Caused by an electrode being removed, falling off or being (re-)attached. This is common if an electrode is placed over chest or arm hair and does not stick well. In this work the effect occurred several times; generally during the tutorial phase, though on one occasion the experiment needed to be paused for a re-attachment to be made - Figure 174 shows a recording of such an artefact.

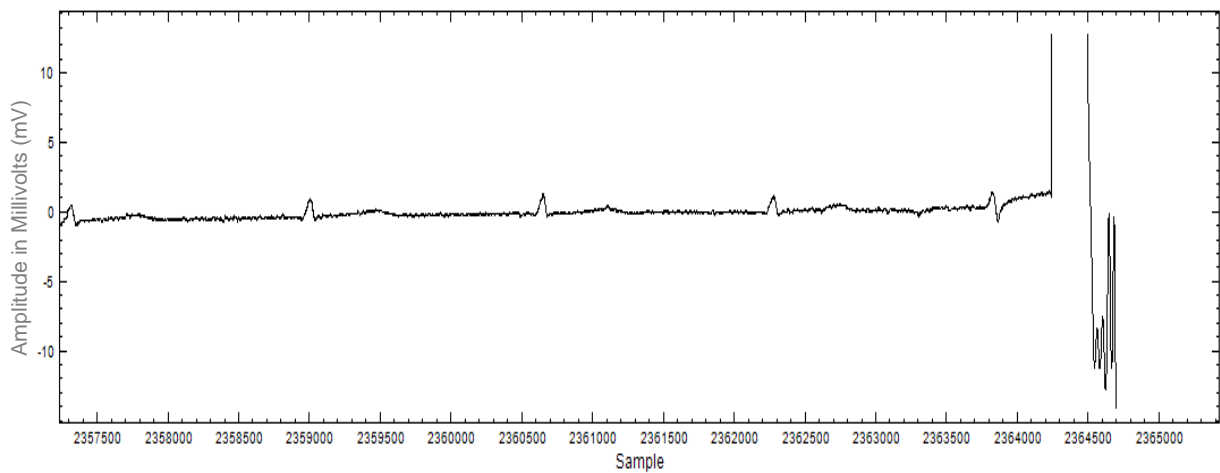

Figure 174: Electrode pop noise as recorded on day two of the experiment.

- Signal processing artefacts; such as Gibbs oscillations;
These are unwanted oscillations in the signal, particularly in response to a sudden change in input. Our data did not suffer from any of these issues outside of artefacts attached to electrode pop noise; which are already removed as un-processable artefacts.

Some of these factors are of a concern to the data we have collected and require an in depth explanation of how they were removed. In the following two sections we will explain in detail our methods for:

- power line noise removal;
- artefact detection;
- baseline correction.

9.1.2. EMG and Power Line Noise Removal

EMG and power line noise compromise the high frequency portion of the noise present in the ECG signal. EMG noise is a high frequency jitter present over the ECG signal caused by movement of the subject. Power line noise is a 50Hz (or 60 Hz in some parts of the world e.g. USA or Canada) sine wave inducted by utility lines into the ECG sensors and wiring. A synthetic version of these noise sources is shown in Figure 175.

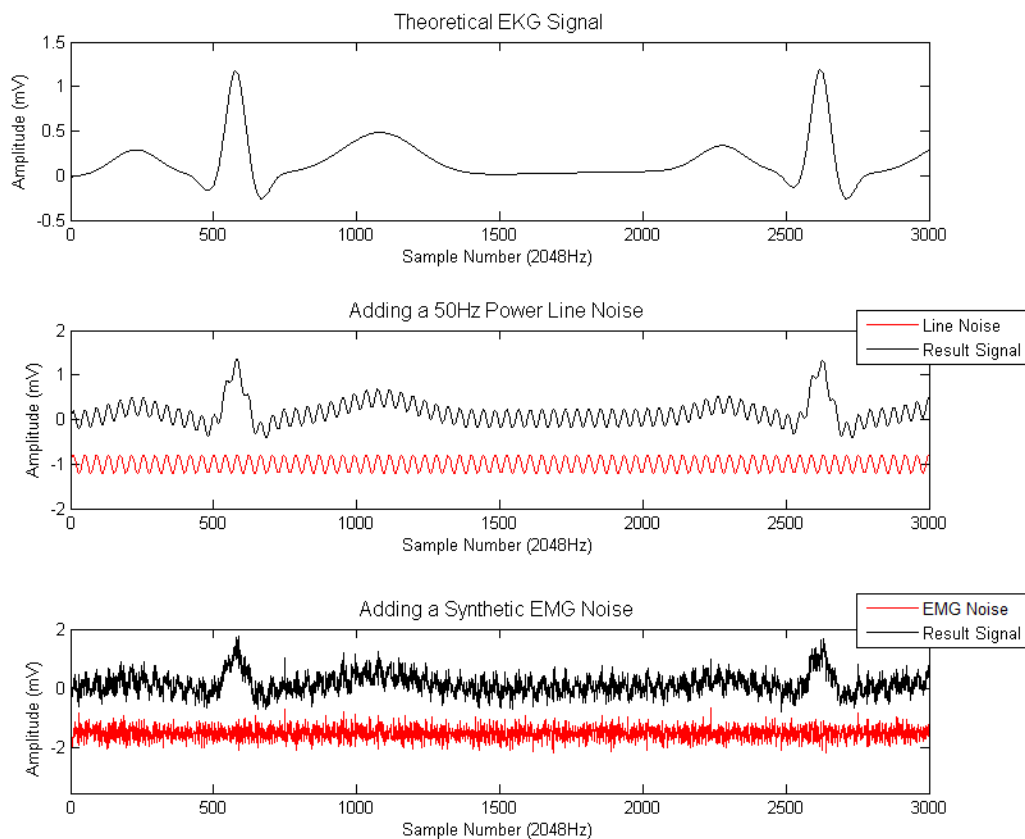

Figure 175: Sources of high frequency noise in the ECG signal.

Several attempts were made to remove the sources of persistent high frequency noise present in our collected data. Initially Savitzky-Golay filtering (Savitzky & Golay, 1964) was employed for EMG noise removal, but for power line noise the results were not acceptable as it introduced alterations to the morphology of the signal being collected (specifically noticeable on the T-Wave, as reviewed by Lehtola et al., 2008). A subtraction method (Levkov et al., 2005) was examined and modified, but it failed

to function correctly on some of our data. Finally a hybrid wavelet based approach was found to be most effective. These alternatives are discussed below.

Savitzky-Golay filtering

The signal was smoothed via a Savitzky-Golay Finite impulse response filter (Savitzky & Golay, 1964). This filter has been shown to be suitable for removal of power line and EMG noise in ECG data by Hargittai (Hargittai, 2005) & Christov (Christov, 2006). Figure 176 shows our work with filtering synthetic ECG signals to observe the effects of Savitzky-Golay filtering on signal morphology.

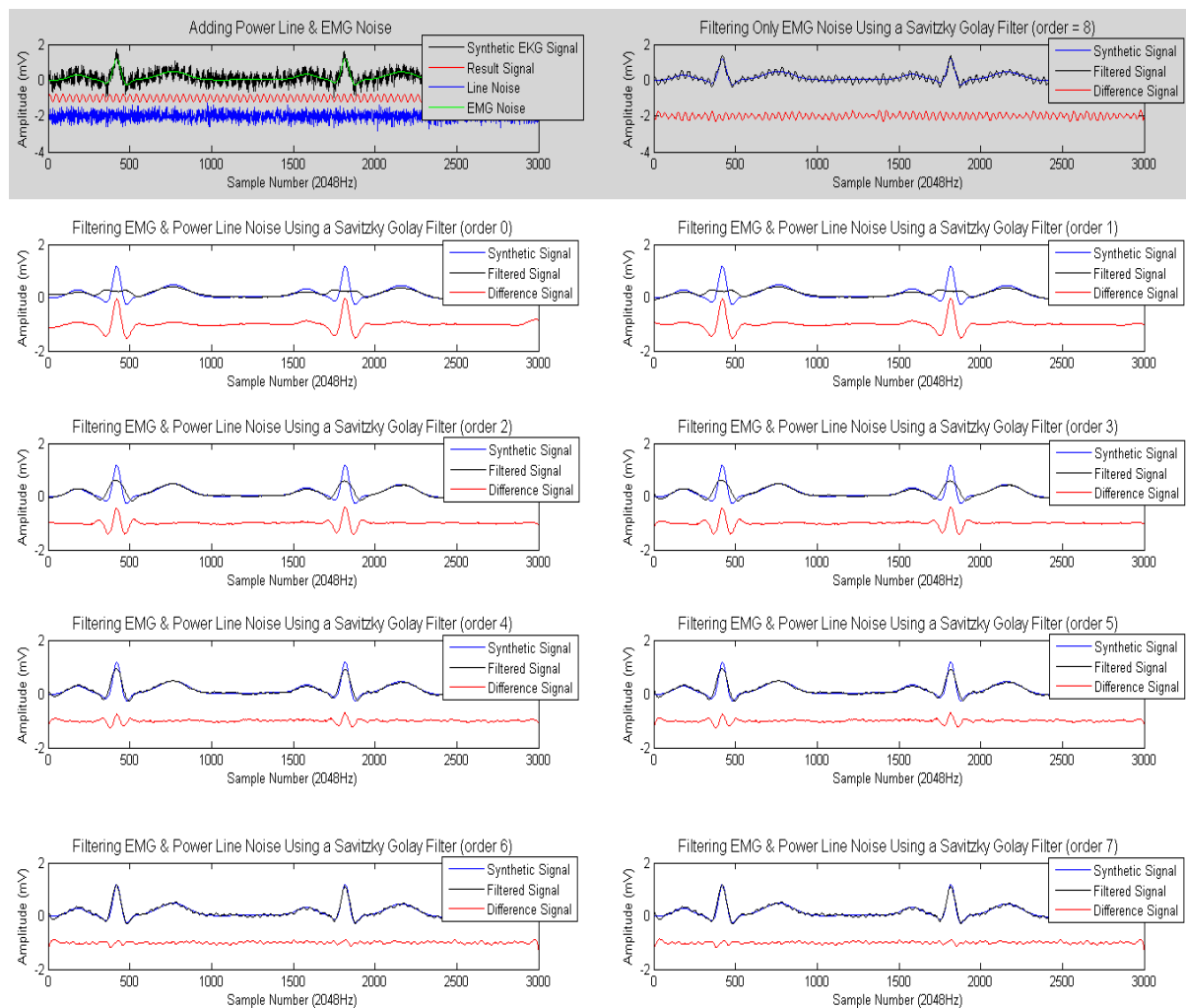

Figure 176: Savitzky-Golay Filtering at Different Orders on Synthetic ECG data. Top left graph is the source signal and its noise components. Other graphs are the result of filtering the signal shown and comparing to the known synthetic data to visualise the error.

We found that setting the Savitzky-Golay filter's frame size to around 0.05 milliseconds produced the best filtering results. However the filter order presented a trade-off. At low filter orders the signal was very smooth, but the morphology was not preserved near the QRS complex. Higher order filters (around 6-7) provided a good representation of the signal's morphology, but were not smoothed. In the synthetic data test filters of this magnitude worked quite well, but the results did not carry through to our real data, mostly because of the large scope of ECG pattern morphology present making the tuning of the filter impossible. Very high order filters (8+) removed the EMG noise very well, but left the line noise in place.

Though the filter could remove much EMG noise from the signal, the variable nature of the ECG morphology collected across multiple subjects make selection of the correct filter order impossible for our requirements of eliminating noise without damaging the signal morphology.

Figure 177 shows the results of using a Savitzky-Golay Finite impulse response filter to remove EMG signal jitter (very high frequency noise) from real data. Note: this signal still has a distinct 50hz line noise, a sample 50Hz sine wave is shown below the ECG.

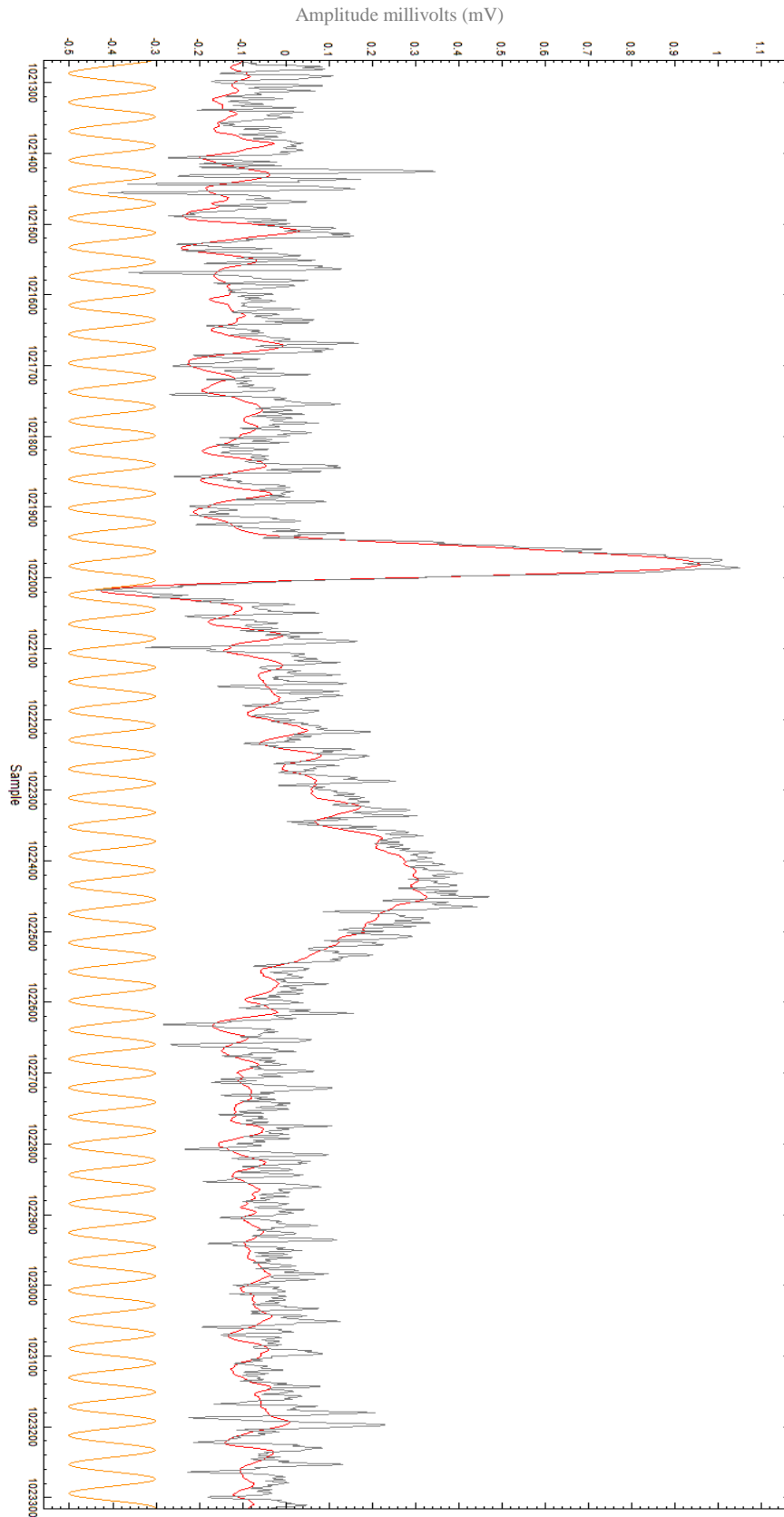

Figure 177: Line noise artefacts (in red) after removing EMG jitter from signal using a Savitzky-Golay Finite impulse response filter. A sample 50Hz sine wave is shown below the ECG

Subtraction Procedure

The subtraction procedure is discussed by Levkov et al., (2005) who stated a problem we also observed in the field of ECG noise removal research:

“Some authors do not present the results of their algorithms correctly or clearly enough to use for interference removal. Sometimes the original signal is not presented [19], no differences between original and processed signals are shown [20]”

The subtraction procedure is a fairly complex algorithm. The algorithm compensates for issues with power line noise removal corrupting QRS complexes. The underlying technique is:

- Low frequency ECG segments are detected using a “linear criterion”;
- These segments are moving averaged (using a linear phase comb filter);
- Interference corrections (phase locked), are calculated for these segments;
- Interference corrections are used to correct neighbouring non-linear segments (QRS complexes and high-amplitude T waves).

Initially we could not reproduce the authors’ result with regard to the effectiveness of the linear criterion described. After some modification to the linear criterion (see Figure 179), our results using the subtraction procedure on the cleaner ECG recordings were satisfactory, an example is shown in Figure 178. We present a full implementation of our function in Appendix 14.5.1.

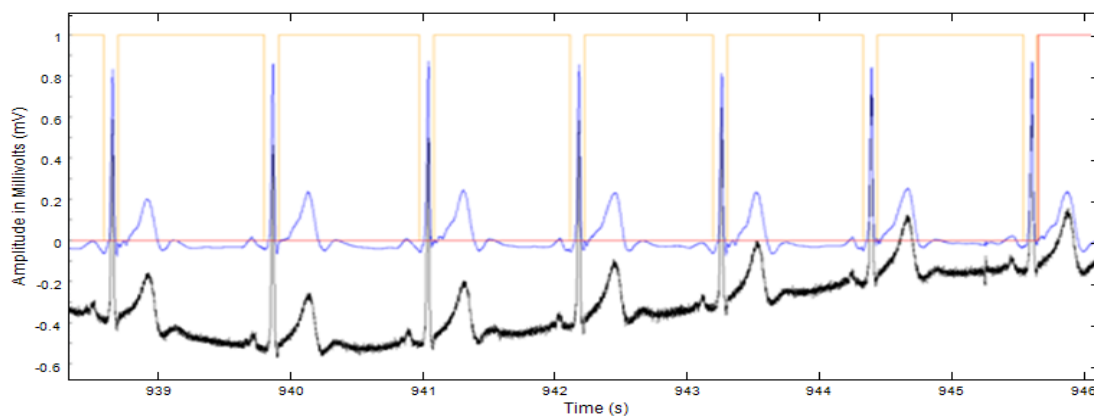

Figure 178: Our results using the ECG noise subtraction procedure as described by (Levkov et al., 2005). The original signal is in black, the baseline and noise corrected version is in blue and the orange lines at the top indicate the linear criterion.

However, even though results for the clean areas of the recording were good, our areas suffering from EMG noise were not adequately resolved. We have reproduced the subtraction procedure's results for medical environment type recordings, but for our type of experiment, which involves minor subject movement, it is not suitable.

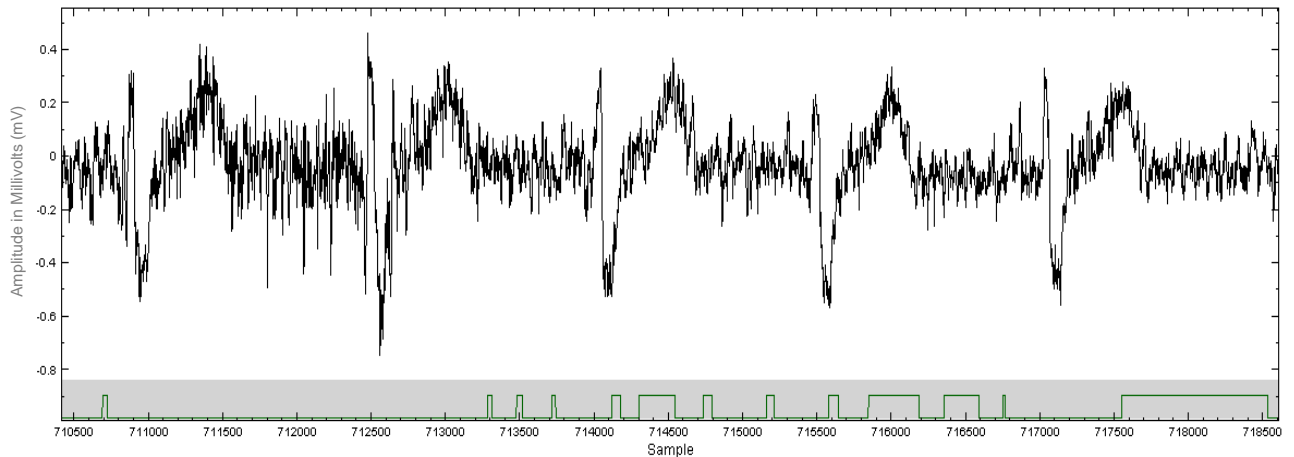

Figure 179: Demonstrates linear criterion (lower line) detection problems when EMG (upper line) noise is present. Notice the noise is decreasing as the signal progresses, resulting in increased linear criterion performance.

Wavelet Based De-Noising of ECG signals

We explored the use of wavelets to de-noise ECG signals and found that, in our synthetic tests, the cleaner signals were not de-noised as effectively as per the subtraction method. However signals with high simulated EMG noise were processed more effectively. Some very high frequency spikes remained, but were trivially removed using filtering internal to the ECG feature detection used. Results on real data are shown in Figure 180.

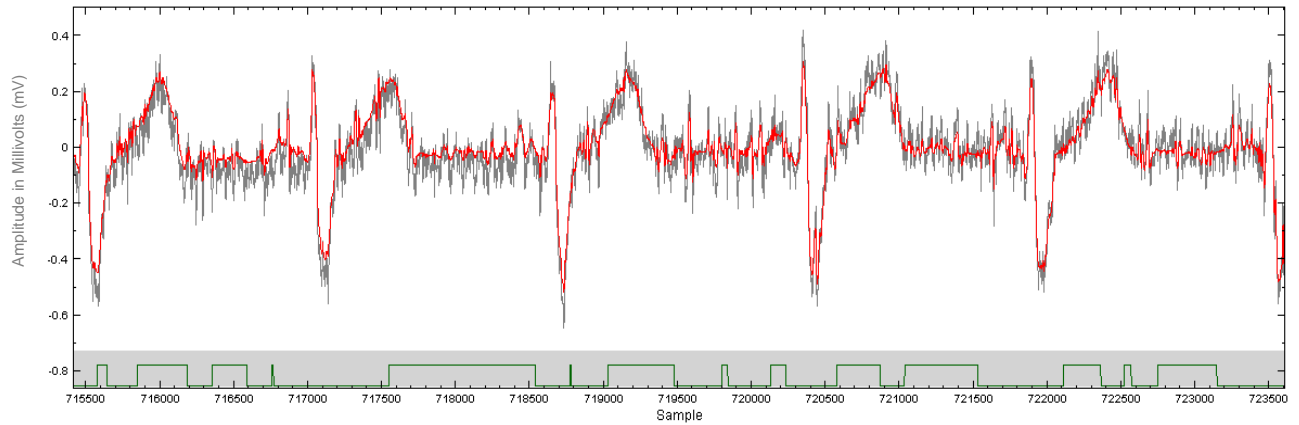

Figure 180: Wavelet processed ECG signal.

Wavelet de-noising techniques are well established, notably that by Donoho (Donoho, 1995) which was referenced in the Matlab ("MATLAB," 2003) "WDEN" function we used for our experiments. Various works have used wavelet de-noising for ECG signals, (Kania, Fereniec, & Maniewski, 2007), (Alfaouri & Daqrouq, 2008) and (Sayadi & Shamsollahi, 2006) which have all shown that wavelet de-noising can be used to effectively process ECG signals.

To test the potential for the wavelet method in our work, we used an artificial ECG signal (duration of 10 R peaks), with randomly created synthetic EMG and power line (50Hz) noise applied. As the original (artificial) signal is known, the performance of wavelet de-noising techniques can be evaluated empirically.

A series of wavelet de-noising processing parameters were examined and ranked by performance;

- Threshold selection rule;
 - a. Stein's Unbiased Risk;
 - b. Heuristic variant of Stein's Unbiased Risk;
 - c. Universal threshold;
 - d. Minimax thresholding.
- Thresholding;
 - a. Soft;
 - b. Hard.
- Multiplicative threshold rescaling;

- a. No rescaling;
 - b. Rescaling by estimation of noise based on first-level coefficients;
 - c. Rescaling by estimation of noise based on all coefficients.
- Wavelet type;
 - a. Haar;
 - b. db1 through db45;
 - c. coif1 through coif5;
 - d. sym2 through sym8;
 - e. dmey;
 - f. bior1.1 through bior6.8;
 - g. rbio1.1 through rbio6.8.

The Matlab de-noising procedure was tested for noise removal with every combination of these parameters. Each test was run over nine different noise level profiles (see Figure 181), with each test repeated three times (a new random seed for the generated noise) to gauge average performance. This produced 21,360 performance experiments.

We evaluated the performance of any given parameter combination using the average sum error squared after the experiment was repeated three times. This was conducted for synthetic random EMG noise at 2, 5 & 10db. Figure 182 shows wavelet performance across the range of EMG noise levels.

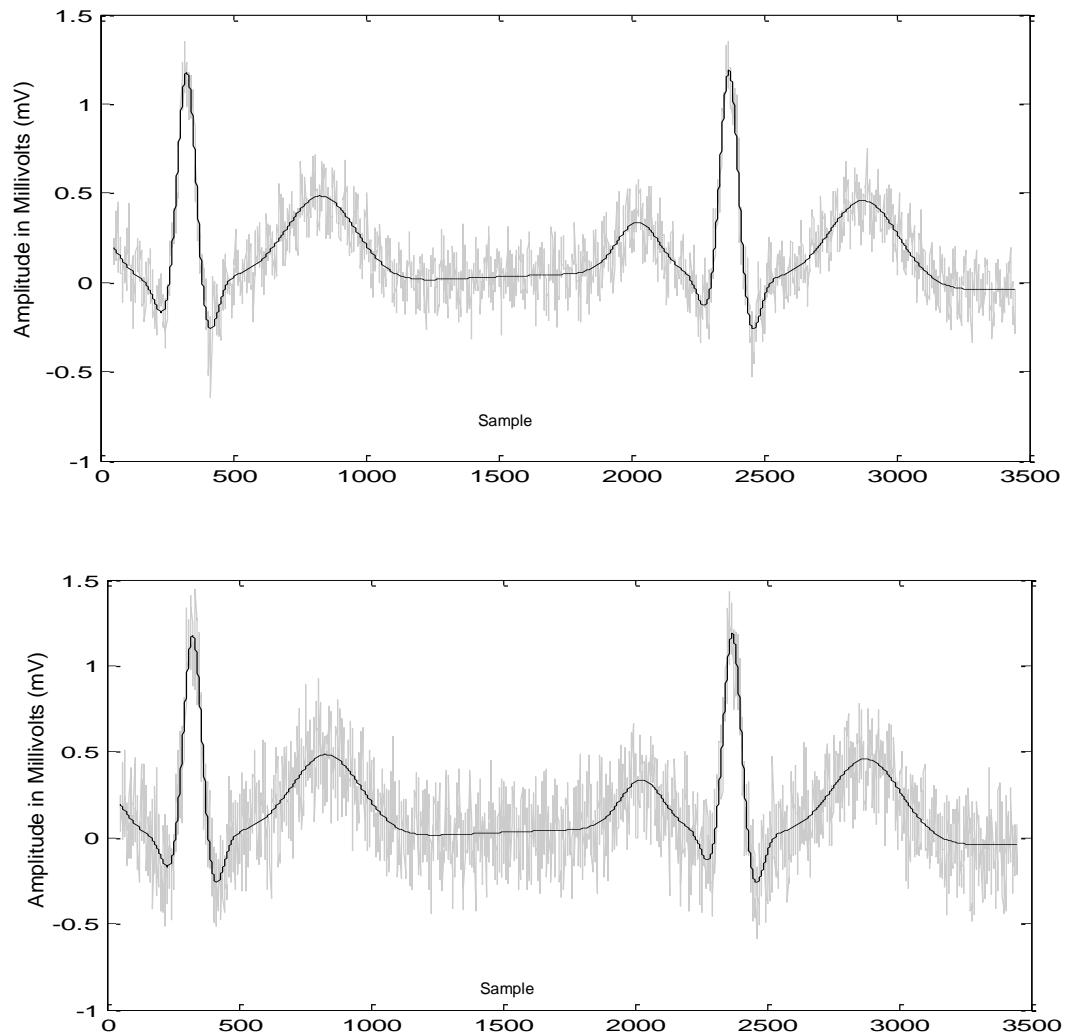

Figure 181: Synthetic ECG noise, 50hz (top), generated at 0.1, 0.2 or 0.3 mV, and EMG (bottom) present at a signal to noise ratio of 2, 5 or 10dB.

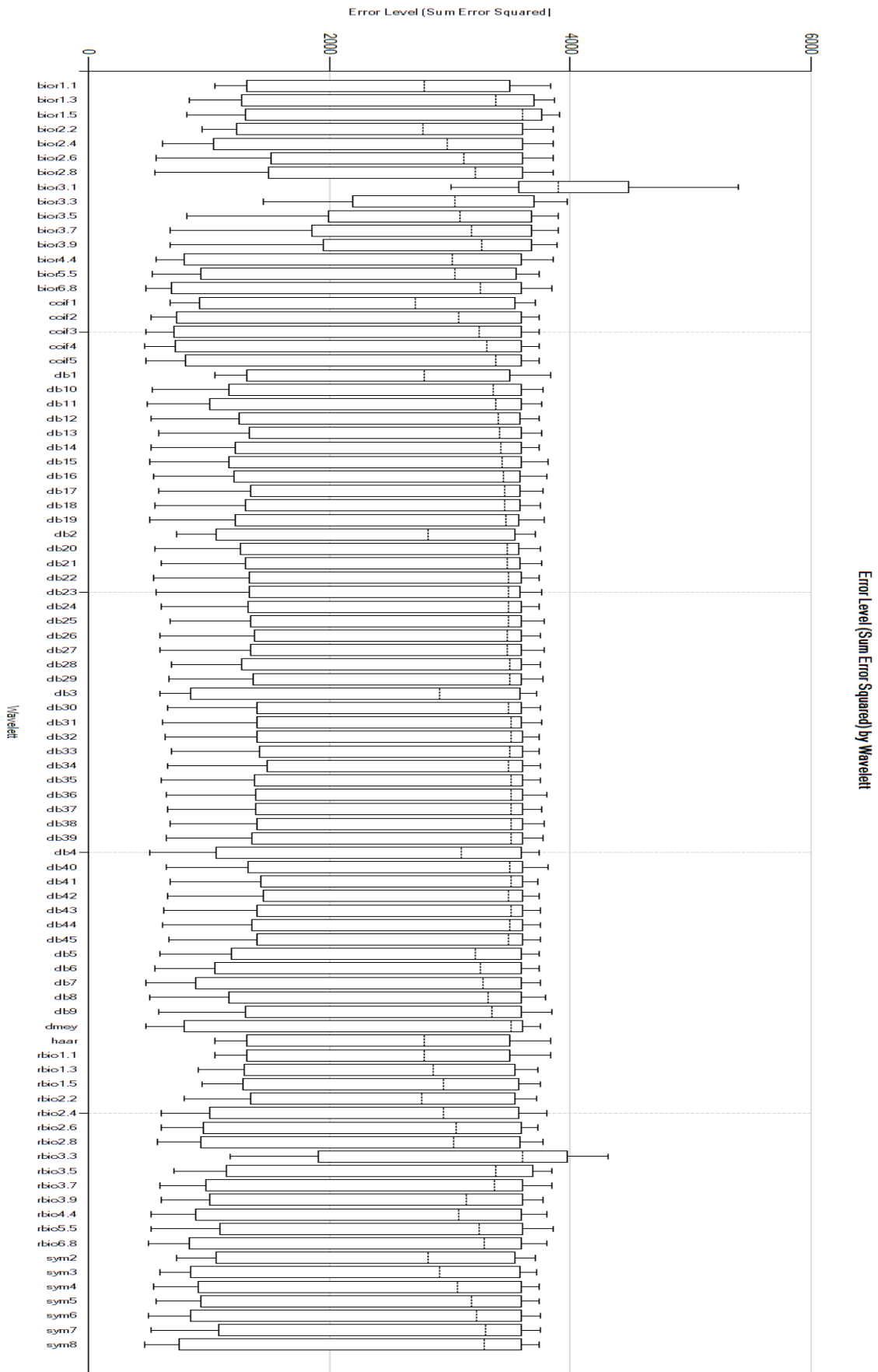

Figure 182: Performance of Different Wavelets in EMG De-Noising (lower results are better).

Other than choice of wavelet function, we found that the EMG noise level and the (wavelet) level at which de-noising was performed had a significant effect on the resulting error levels. Figure 183 shows the effect of the synthetic EMG Signal to Noise Ratio (SNR) on the error rate of the signal de-noising across all wavelets.

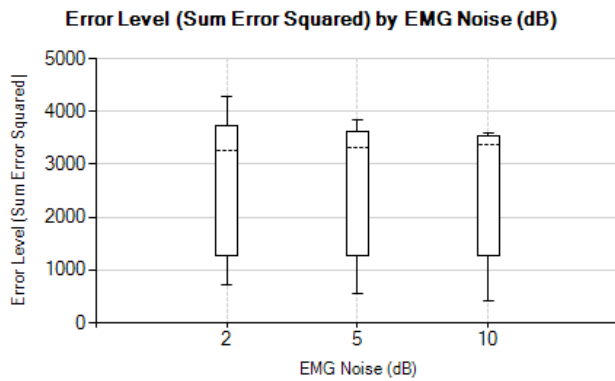

Figure 183: Error level by EMG noise (lower error level results are better). Note: The noise is expressed as signal to noise ratio so lower values mean more noise.

Figure 184 shows our results for error levels by the level of the wavelet.

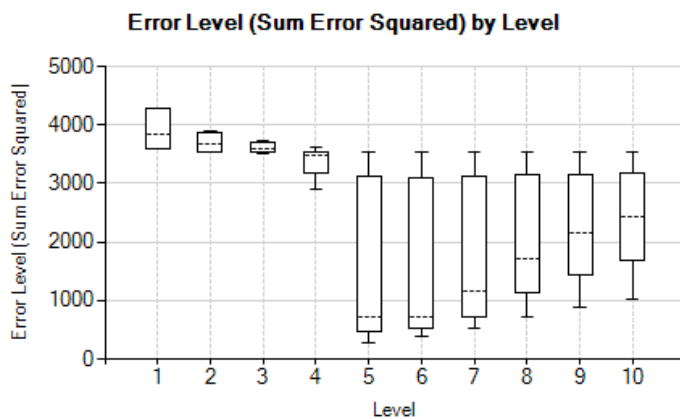

Figure 184: De-Noising Performance by decomposition level (across all wavelets)

From our data we identified 15 mother wavelets based on their performance (biased towards higher EMG SNT ratios): sym7, coif4, db7, sym8, bior2.8, db4, coif4, coif3, coif5, bior3.3, dmey, coif2, sym3, sym2, db2. We found that de-noising at the 5th level was most productive. Though less noticeable in effect we also decided on using Stein's unbiased risk threshold selection rule with soft thresholding and multiplicative threshold rescaling performed by estimation of noise based on all coefficients.

These 15 wavelets most likely are a best fit to our work, on different datasets different (but similar) wavelet sets may be more favourable, and the effect of using another appropriate set on this data would not be too significant.

In comparison, a similar study to our wavelet de-noising investigation by Kania et al., (Kania et al., 2007), which was performed on real data with heart arrhythmias, found a similar set of wavelets to be effective (using the Matlab WDEN function); namely: sym3 and db1..db4.

A non-trivial task in improving the quality of the de-noised signal is removing the high frequency pseudo-Gibbs artefacts (unwanted ringing in the signal) that are occasionally generated by wavelet de-noising. Though Matlab uses thresholding techniques to minimise the pseudo-Gibbs phenomenon, some artefacts remain. These artefacts are often reported in works using wavelets to de-noise ECG signals, eg (Su & Zhao, 2005). A sample pseudo-Gibbs artefact is shown in Figure 185.

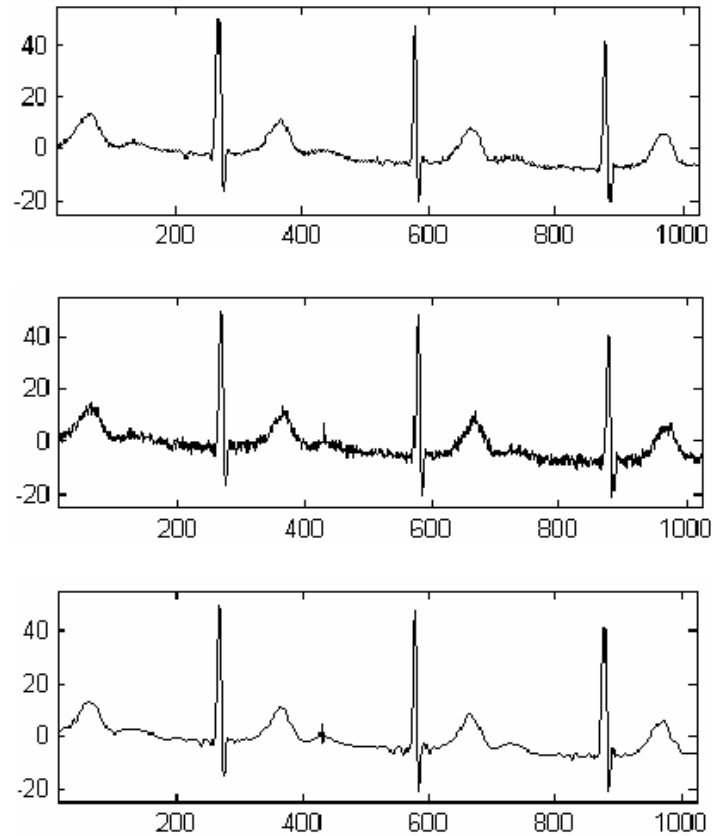

Figure 185: Pseudo-Gibbs Artefact (Su & Zhao, 2005). Top graph is source signal, second graph is noisy version, third graph is the wavelet de-noised, showing only minimal pseudo-Gibbs artefacts near the Q and S portions of the ECG signal.

Many high frequency pseudo-Gibbs artefacts were removed by a simple filtering integrated into the feature recognition procedures (discussed in section 9.1.6), we wished to clean up the signal as much as possible before this stage. After some experimentation, we devised a method to de-noise the signal using all 15 identified wavelets together.

The method involved computing a resultant signal where every point in the new signal was a function of the corresponding samples from each of the 15 source wavelets. The function being the mean of all samples within one standard deviation from the mean of the 15 source samples. This is a form of outlier rejection. If the source wavelets were less than 9 a Q-test could be substituted. This technique is a variant of that presented by (Yang & Wei, 2010).

The final results were often extremely smooth for areas where EMG noise saturated power line noise, but less successful for areas of evident power line frequencies. Figure 186 brings to focus an area of many artefacts and shows both our typically best results in removing them (the first three heartbeats) followed by examples of poor results in the next three heartbeats.

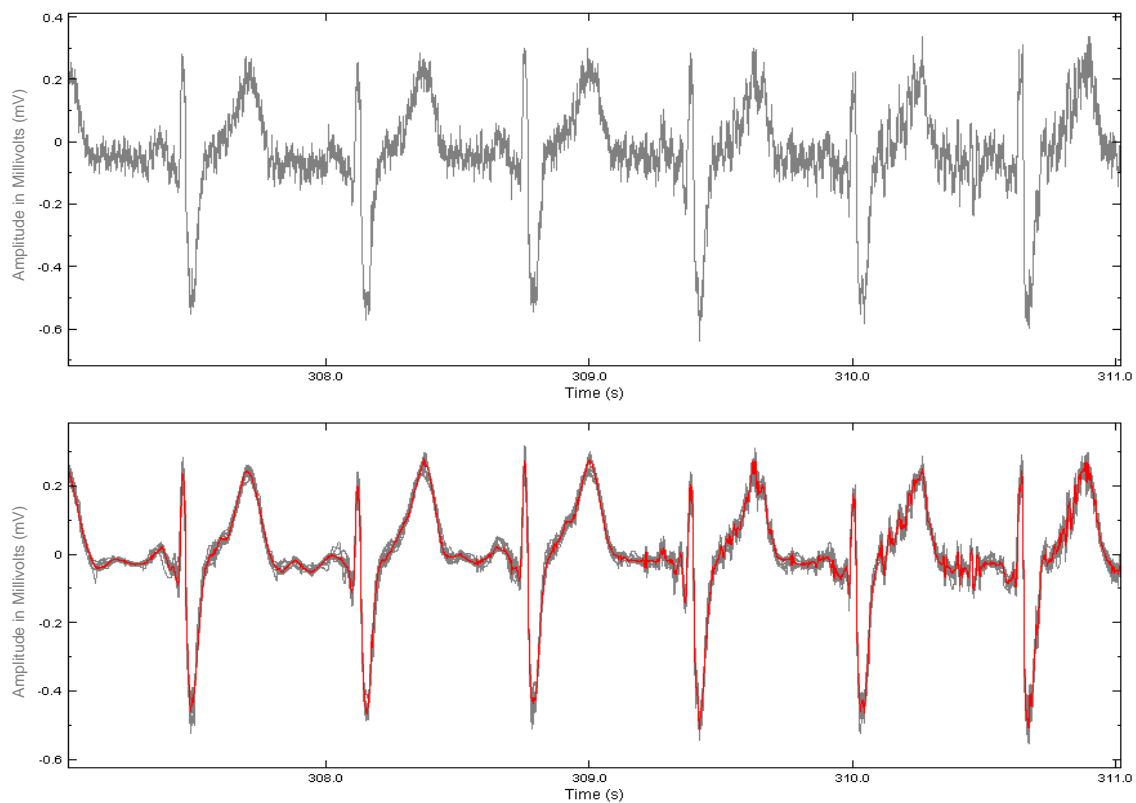

Figure 186: Multiple Wavelet De-noising Technique (above). Raw Signal (below) Average wavelet in red superimposed on 15 key wavelets (gray).

Summary of ECG De-Noising

There are a lot of techniques that can be used to de-noise the ECG signal. We found that the choice of technique could depend heavily on the intended use of the ECG signal after filtering. In this study the requirements of the de-noised signal were different to many other situations that typically use ECG data. For example, signal morphology around the Q,R,S and T waves was considered more important than other factors such as Signal to Noise Ratio (SNR). In this manner, some decisions on the necessary filtering required were subjective in nature.

For our requirements, the wavelet based approach gave the best results from the techniques investigated. In contrast, our implementation of the subtraction procedure of Levkov et al., (2005) did not perform well for the levels of EMG noise that were present in some of our data and we found Savitzky-Golay filtering to be useful, though difficult to tune. A version of Savitzky-Golay filtering that automatically adjusts its parameters to suit the data present would be an interesting point for future research as our wavelet approach was not without some minor artefacts.

9.1.3. **Artefact Detection**

Some portions of the signal were so corrupted by effects such as EMG noise as to be extremely difficult to repair. In other applications, such as those involving subjects that are exercising, and such noise is prevalent, special strategies are adopted to repair this data (Pahlm & Sornmo, 1987). This non-trivial task can be assisted by collecting accelerometer data to assist in the processing (Raya & Sison, 2002). However, in the case of our experiments, where the subject is stationary and only a small proportion of data is affected by this problem, we chose to discard the corrupted portion of the signal. As such we discarded all data that failed basic thresholding (amplitude range checking) tests.

9.1.4. **Baseline Drift correction via Median Filtering**

Traditional baseline drift correction involves using a high pass filter to remove the slower change to the base line. This approach has been used to correct baseline drift in ECG signals by various works including de Chazal, Penzel and Heneghan (2004).

However, distortion incurred by various high pass filters often interferes with and distorts the features of the ECG (Hambley, Moruzzi, & Feldman, 1974), (Van Alste & Schilder, 1985) and (Warlar & Eswaran, 1991). A popular method of baseline correction uses median filtering to estimate the signals base line. The estimated base line was then subtracted from the signal to flatten the signal into a straight line with minimal effect on the ECG attributes. Many works have used this approach (Shouldice & Heneghan, 2001), (Correa, Laciari, Torres, & Jane, 2008), (de Chazal et al., 2003) and (Yu, Liu, McKenna, Reisner, & Reifman, 2006).

Like many other projects, this work had access to median filter algorithms provided by Matlab and other major vendors. Upon investigation, it was found that the commercially available solutions were extremely costly in terms of memory usage and computational time when the size of the filter window exceeded 2000 samples.

As ECG processing is one of the few major applications for using a median filter with a large window size, the computational complexity is not commonly addressed. It was our conclusion that (on the hardware of the time, circa 2004) it was not a viable solution to perform the filtering using the existing algorithms available to us. This is not an unprecedented stance, some researchers do state median filtering as being very slow, Shouldice described the extent of the problem (Shouldice & Heneghan, 2001) as such:

"It was found that calculating the median at each step value, say for four seconds of data (4000 samples), led to a very long execution time - even for short data segments. As a consequence, this approach was not considered feasible for entire GB datasets".

To address this issue this work developed an efficient and novel real-time median filter to perform baseline correction with minimal memory overhead. This is not the first implementation of fast median filtering, recent publications such as (Little & Jones, 2010) have described filters which offer "10:1 performance gains for large window sizes" over the Matlab implementation. However our approach was novel at the time, fast and developed separately from the recent works. We have included a description of the algorithm and a performance comparison in appendix 14.9.

Using a filter window of two seconds, an accurate baseline was detected on almost all of the data recorded in this experiment. This was similar to many works, such as (Korürek & Nizam, 2008), however, occasionally this window size failed to correctly correct for baseline drift. Trying larger window sizes in half second increments, and visually inspecting the entire data set each time, we eventually found a four second window worked best for our data. The window size may have been longer for these cases because of differences in hardware and our preference not to use inbuilt filters

provided by the equipment manufacturer. A typical result is shown in Figure 187 where the signal drifts considerably and a smooth baseline is detected.

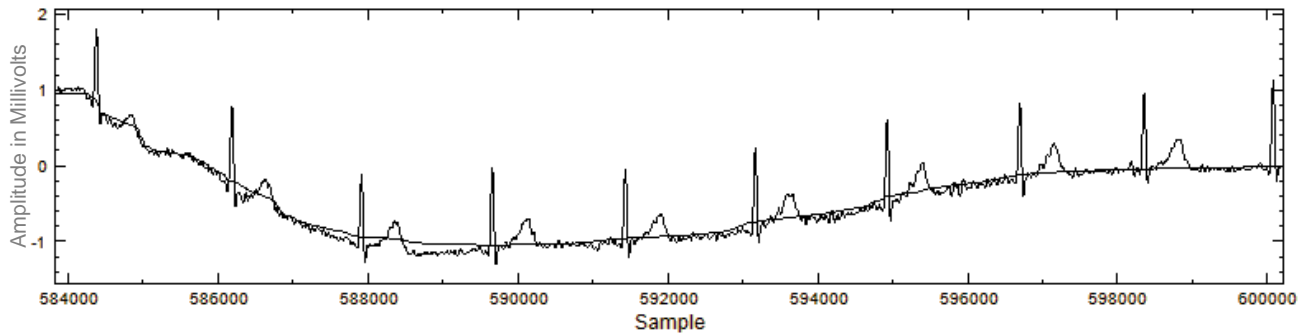

Figure 187 An Extreme Instance of Baseline Drift. The baseline is detected using median filtering and is shown as the curved line running through the signal.

The next stage after detecting the drift is compensating by subtracting the base line. Figure 27 shows the result of correcting the signal in Figure 26. Note the signal is shown from a starting point four heartbeats earlier to show both positive and negative correction performance.

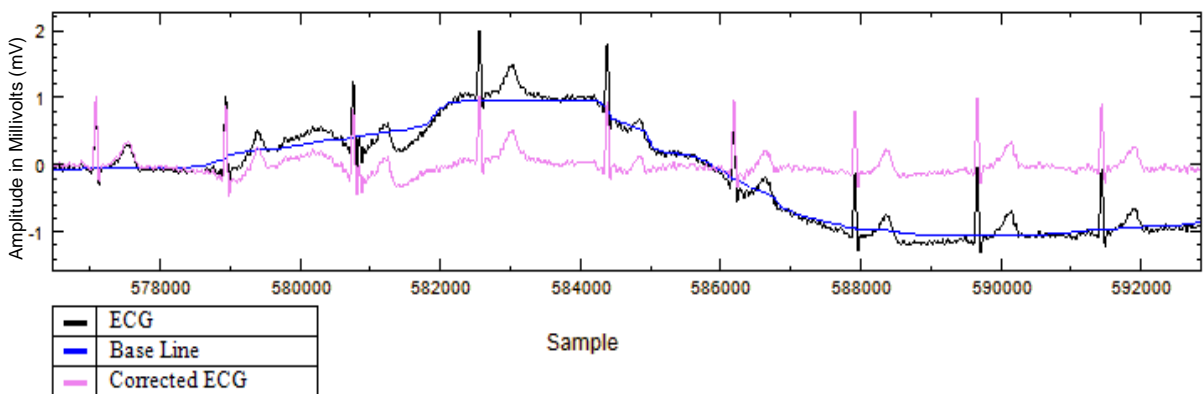

Figure 188 Baseline corrected ECG signal.

After the signal has been baseline corrected the filtering of the ECG signal is complete. At this point we can use the “cleaned up” signal in a feature extraction process.

9.1.5. Overview of Feature Detection in the ECG Signal

A feature vital to the quality of ECG analysis is synchronisation with the cardiac beat. This is achieved through the detection of the Q, R and S waves, known as the QRS complex. An idealised version of the QRS Complex is shown in Figure 189, as the most prominent feature of the signal, it is typical to detect this complex first and then examine the data between consecutive QRS complexes. We explain the issues involved, discuss our unsuccessful attempts to build a QRS detector from ground up, and share issues we had in adopting two existing algorithms to our needs.

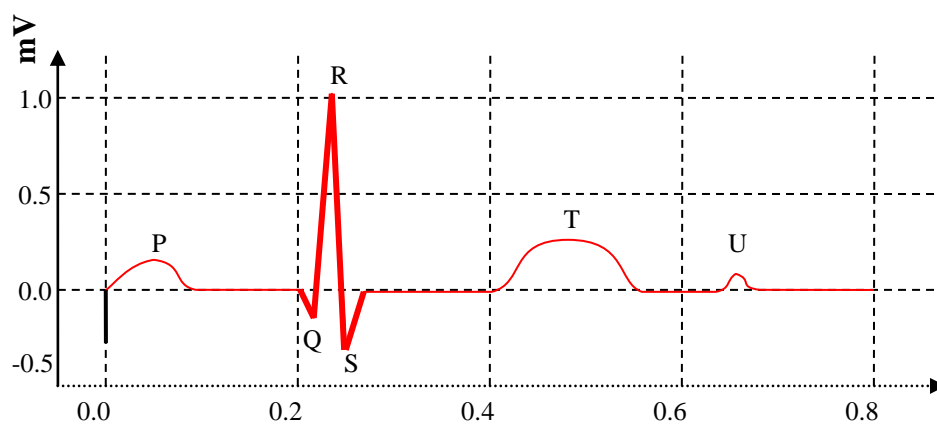

Figure 189: Typical ECG Signal - QRS Complex

It has been shown (Silipo, Laguna, Narchesi, & Mark, 1995) that the correct detection of the QRS complex is necessary for accurate and reliable measurement of the wave form parameters that will be used in our classification task.

The appearance of the QRS complex will vary from that shown in Figure 24 depending on which sensor placements are used. Though many variations are possible (see Figure 190) this experiment utilised a sensor placement which produces the typical ECG waveform. As such we will not concern ourselves with dealing with other variations for the purposes of this study.

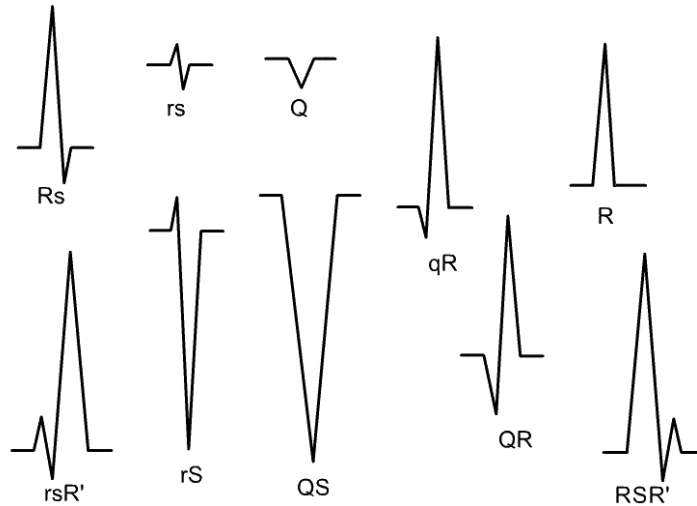

Figure 190 Nomenclature of various possible QRS intervals.

The American Health Authority AHA (Bailey et al., 1990) recommends the use of techniques based on spatial velocity calculations to formulate an evidence variable for the detection of the QRS complex. This work has attempted a QRS complex detector based on these recommendations. We attempted to validate our algorithm using sample data obtained from the MIT-BIH (Taddei, et al., 1992) and ST-T (MIT-BIH, 2003) databases. The initial QRS complex detector implemented in this work was found to be problematic. A major problem was that even though we correctly found QRS complexes, the exact point of the peak was often difficult to determine, and our algorithm gave a slight error which was inconsistent. This led to data which showed minor variations in intervals that did not exist. Our goal was an algorithm that was more consistent in determining the peak position. As our attempts to build a QRS detector from ground up were problematic (sufficient accuracy could not be achieved), an existing solution was sought.

Our first attempts at finding an existing suitable QRS detector involved the porting and adaptation of an implementation (P. Hamilton, 2001) of a major work in the field of QRS complex detection, the Hamilton-Tompkins algorithm (P. S. Hamilton & Tompkins, 1986). This algorithm improved on the also notable Pan-Tompkins algorithm (Pan & Tompkins, 1985). The Hamilton-Tompkins and Pan-Tompkins algorithms are the most popular single-lead ECG QRS detection methods and have

been widely used in the past two decades for Heart Rate Variability (HRV) analyses. A notable downside to the Hamilton-Tompkins algorithm is its reliance on a QRS detection threshold that must be experimentally determined.

Finding good threshold values proved to be a participant specific task; which was still ineffective for some participants. A later update (ver. 1.3) of Hamilton's implementation (Hamilton, 2001) noted some improvements to the threshold implementation. As this update did not come to our attention until after the QRS work was completed it was not evaluated.

A recent advancement to this work is a Hilbert transform-based method, proposed by (Benitez, Gaydecki, Zaidi, & Fitzpatrick, 2000), which uses a variable detection threshold that does not need to be experimentally determined. However no existing implementation was available.

A second attempt to obtain a suitable QRS detector focused on the porting of the (original) Pan-Tompkins algorithm (Pan & Tompkins, 1985). We used a reference implementation (Pablo Laguna, Jané, Bogatell, & Anglada, 2000) that was part of the PhyioNet Toolkit (Goldberger et al., 2000) and adapted it to work in our software infrastructure. Though more consistent across participants, positional accuracy issues in peak and onset detection were a problem.

Positional accuracy and consistency of detection points across QRS complexes were a key requirement for our classification procedures. If detection of peaks and onsets are variable or altered by individual ECG wave form characteristics, then we may be introducing artificial variations in inter/intra beat feature length measurements. Looking for a better performing algorithm in regards to these requirements, we ultimately found a reliable technique involving wavelet decomposition.

9.1.6. **Wavelet Decomposition and Automated ECG Annotation**

In this section we discuss a work by Chesnokov, Nerukh and Glen (2006) that used wavelet decomposition to reliably achieve automated ECG annotation.

The major difficulty in finding the components of the ECG signal stems from the fact that they are small in terms of amplitude and exist in a portion of the frequency spectrum that also picks up muscle noise and motion artefacts. A comprehensive study by Thakor et al., (1984) produced a workable estimate of the ECG power spectrum that demonstrates the nature of P and T waves in relation to the rest of the data present in the ECG signal, this was previously discussed in Section 9.1.1, where Figure 170 showed the overlap of motion artefacts and the P-T waves.

As peoples' recorded ECG morphology is quite different; it is often the case that a feature extraction algorithm will fail to detect portions of a signal, because they are simply not present in a signal. Kunzmann and Bolz (2002) defined a successful beat detector as one that detects:

- P-wave:
 - Time of the beginning, maximum, end;
 - Amplitude.
- QRS:
 - Time of the beginning;
 - R-spike;
 - End of wave;
 - Amplitude.
- T-wave:
 - Time of the maximum/minimum (depending on the polarization);
 - 2nd extremum (if available);
 - End of wave;
 - Amplitude deviation and slope.
- ST:
 - Derived parameters: RR-interval, PQ-interval, QT-length.

It is important to note that the above criteria for successful beat classification ignore the U wave. The U wave is seen as extremely difficult to detect, and is often excluded from discussions on ECG beat detection.

The wavelet decomposition based algorithm, with source code, provided by Chesnokov et al., (2006) was able to demonstrate the best detection performance when compared to a host of similar algorithms during the PhysioNet (Goldberger et al., 2000) Computers in Cardiology Challenge 2006. Typical results on our data are shown in Figure 191.

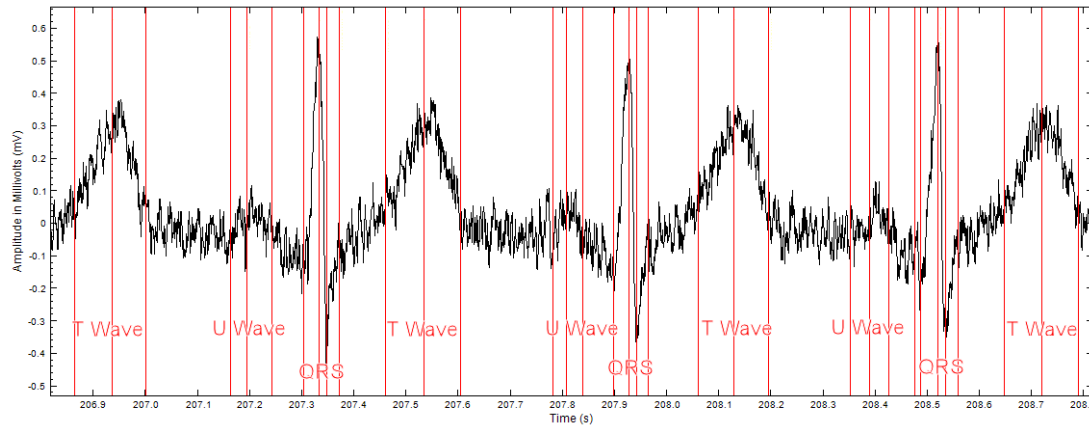

Figure 191: ECG Annotations Against Raw ECG signal.

The algorithm created by Chesnokov et al., (2006) used 14 separate parameters to tune the algorithm. When contacted, Chesnokov was helpful in providing us with some necessary guidance regarding the parameters.

9.1.7. Extraction of Training Data from the ECG

Two major tasks often facing conventional ECG classifiers are detection of abnormal morphology and general morphology classification. Recent works in general morphology classification include Iliopoulos and Michalakopoulos (2006), Gholam Hosseini, Reynolds, and Powers (2001) and Güler and Übeyl (2005). Most current work in this stream of research uses wavelet encoding parameters as input to neural networks to detect features of the ECG. This is relatively successful with Güler & Übeyl (2005) achieving a 97% successful beat classification algorithm.

Though successful, the bulk of current investigative efforts in ECG are driven by medical research aimed to detect abnormal heart activity or identify features that may indicate health issues with the heart. Often key metrics extracted from the ECG

include Heart Rate Variability (HRV) (Saykrs, 1973) and QT Intervals. These tasks are different in nature to the objectives of our classifier which involves the studying of short term variations in relative morphology to detect emotional state.

Many works have studied the ECG in relation to emotion. Some works use the measures established as medically useful. A recent example is Villon & Lisetti (Villon & Lisetti, 2006) who used HRV to detect emotion in real time. Others use wavelet decomposition parameters, for example (Sarkar, 2002) shows this to be a plausible method for determining some human physiological states.

Standard waveform properties that do not rely on the morphology of the ECG have also been used. A recent and interesting result by Katsis et al., (Katsis et al., 2008) was the detection of stress, disappointment and euphoria (possibly none of these are emotions) in racing car drivers using ECG metrics of RR interval, mean amplitude and the mean absolute first difference defined for a 10 second window. Their formula for the mean absolute first difference is shown in Equation 6.

$$md = \sum_{1}^N \frac{|x_{2-} x_1| + |x_{3-} x_2| + \dots + |x_{N-} x_{N-1}|}{N}$$

Equation 6: Mean absolute first difference, where N is the sample rate multiplied by 10s and $X_{0..n}$ is the signal.

The use of non-morphological indicative parameters by works such as Katsis et al., (2008) may be an advantage in an environment where the subject is non-stationary and thus creating a lot of EMG interference to the ECG signal.

9.1.8. Invariant Feature Selection from the ECG

Many of the studies identified thus far use heart rates and statistical methods to identify features to be used in classification. However there still appears to be a need to investigate ECG morphology in relation to emotional influences. We are visiting the task using a broad range of features extracted from the signal and attempting to discover any correlations. We are not basing this work on features currently well studied by the medical community as our goals are different.

A major difficulty in dealing with ECG features is the variation in morphology between people. Much of the work that pioneered the field of ECG based diagnosis dealt with these issues and is famously studied by the Nobel prize winning doctor and physiologist Willem Einthoven (Einthoven, Fahr, & De Waart, 1913). They established that many people generate differently shaped QRS complexes and have different mean ECG feature intervals.

For our purposes of finding invariant features, another difficulty that arises is the variation in morphology based on increased or decreased heart rate. A pioneering work in correcting ECG features, to be heart rate invariant, was conducted in 1920 by physiologist Henry Bazett (Bazett, 1920). Their work created a formula to generate a heart rate corrected QT interval. Bazetts' Formula, shown in Equation 7, for correcting the QT by the square root of the R-R interval became a standard metric (QTc) for detecting increased risk of ventricular arrhythmia.

$$QTc = \frac{QT}{\sqrt{RR}}$$

Equation 7: Bazetts Formula (Bazett, 1920)

This formula is nonlinear, which is in congruence with Bazzets (1920) work which showed that feature intervals in the ECG do not increase linearly with heart rate. Bazzets work, though still used, was based on data manually obtained from real ECGs from 39 young men. More recent research by Sagie et al., (Sagie, Larson, Goldberg, & Bengtson, 1992) found this work over-corrects at high heart rates and under-corrects at low heart rates. Sagie et al., proposed a more accurate formula shown in Equation 8.

$$QT_{lc} = QT + 0.154(1 - RR)$$

Equation 8: Improved formula for QT correction

While the QT interval has been well studied because of its correlation to medical conditions, there has been little (published) work to study the effect of increased heart rate on other ECG features.

As this work aims to study a broad set of ECG features it was necessary to derive formulae for creating heart rate corrected and person invariant features. Thus we extended the concepts put forward by Sagie et al., (1992) into all the other inter/intra beat intervals. We term this set of transforms, the Normalised Adjusted Relative Features (NARF) transform, it is shown in Equation 12.

Firstly a feature (F) is defined as the interval between two points of interest in the ECG. The set of readily identifiable features in the ECG is given in Equation 9.

$$F_{ij} = |i - j|$$

Equation 9: An Arbitrary feature interval, from feature i to feature j, where i and j are positions of a sample.

The full set of recorded F_{ij} intervals in our collected data is plotted against the corresponding RR interval in which it occurred. This creates a scatter plot to which a polynomial curve can be fitted. The resulting coefficients of fitting a second order polynomial to the points are termed A_{ij} , B_{ij} and C_{ij} . Thus we can calculate a predicted interval (PF_{ij}) for any F_{ij} for a given RR interval as per Equation 10.

$$PF_{ij}(RR) = A_{ij}(RR)^2 + B_{ij}(RR) + C_{ij}$$

Equation 10: A prediction of feature interval given at the RR period.

Any observed feature interval can then be expressed as a percentage of its predicted duration (PF_{ij}) for the current RR interval. the resulting metric is termed the relative feature (RF_{ij}) as per Equation 11.

$$RF_{ij(n)} = \frac{F_{ij(n)}}{PF_{ij}(RR_{(n)})}$$

Equation 11: A Relative Feature, Corrected for Heart Rate

Since each participant has a different mean and standard deviation, we normalise the results to make the features invariant across participants. The resulting metric, termed $NARF_{ij}$, is given in Equation 12. Results for every inter/intra beat NARF transform are given in 14.4.

$$\mu_{ij} = ARF_{ij} = \frac{1}{N} \sum_{n=1}^N RF_{ij(n)}$$

$$\sigma_{ij} = \sqrt{\frac{1}{N} \sum_{n=1}^N (RF_{ij(n)} - \mu_{ij})^2}$$

$$NARF_{ij}(n) = \frac{RF_{ij(n)} - \mu_{ij}}{\sigma_{ij}}$$

Equation 12: The NARF Transform

9.1.9. Summary of ECG Processing and Feature Extraction

In this section we have explored a set of noise filtering and feature extraction techniques for the processing of ECG signals. A summary of steps taken is as follows:

- We used a wavelet de-noising technique to remove high frequency noise. The technique used was based on existing theory but also contained an amount of original work;
- We used median filtering to achieve baseline correction. To achieve this goal we developed a novel median filtering algorithm that had improvements in computational efficiency over many existing works;
- We employed an existing, pre-verified, feature detection software to discover the location of recognisable signal features.

Our data for classification purposes is derived from durations between the morphologically identifiable points on the periodic ECG signal. We extended the work of Sagie et al., (1992) to correct for all feature intervals, not just the QT interval. After normalising this data we have metrics that are usable in our classification tasks.

9.2 EMG Signal

Surface Electromyography (sEMG) is a conventional and well-studied measure of muscle activation. sEMG is used in a variety of research applications including affective sciences, sport sciences, human kinematics research and injury rehabilitation, artificial limb control, neuromuscular disorder treatment and ergonomics evaluation.

Many affective science studies focus on sEMG activation levels and use thresholding techniques and a limited set of features to assess the presence of muscle

activation and perform emotion classification on that data. We implemented a similar system and extracted a simple high/low feature from our EMG signals. Typical results are shown in Figure 192. Preliminary analysis suggested a wider feature set was required, as a simple boolean output was insufficient. Thus the thresholding work was abandoned in favour of some more descriptive metrics.

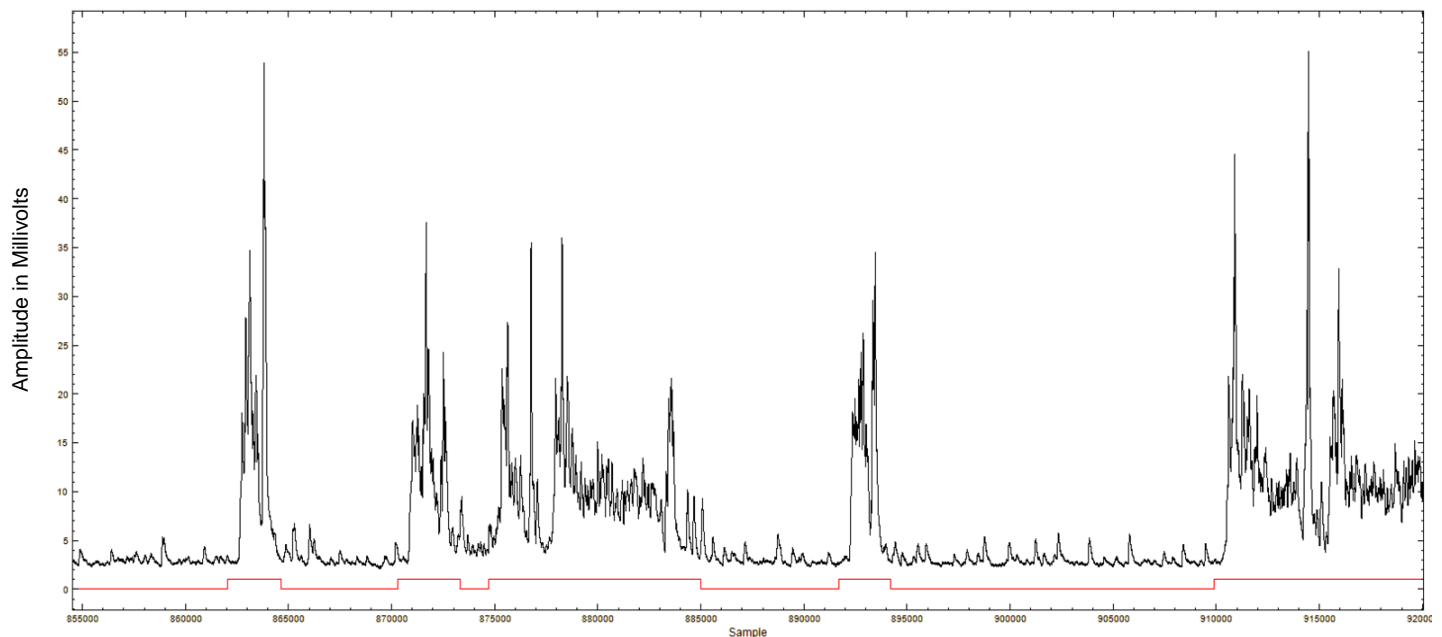

Figure 192: EMG Thresh holding

To find a wider set of features for investigation, a broad cross section of features commonly extracted from the sEMG signals in other fields of research were studied for their applicability to emotion recognition tasks.

9.2.1. EMG Feature Extraction

Two major groups of features can be extracted from the EMG; amplitude based features and frequency based features. It has already been established that amplitude based features of facial EMG data are significant features in emotion classification. Studies such as Nakasone et al., (Nakasone et al., 2005) clearly link amplitude based features with the Valence component of dimensional emotion models. However the validity of using frequency based diagnosis specifically for the corrugator muscle in respect to emotion classification has not been investigated, to our knowledge.

To determine whether an investigation of frequency based features was needed we took spectrograms of frequency features and compared them to the corresponding time domain signals to establish if there was any degree of dependence in the two domains. Figure 193 shows typical results of the investigation visually. Some frequency domain activity, such as in the 70s-80s time span, has no correlating time domain activity. This effect, though subtle, was observed often and as such supports the validity of frequency domain feature extraction.

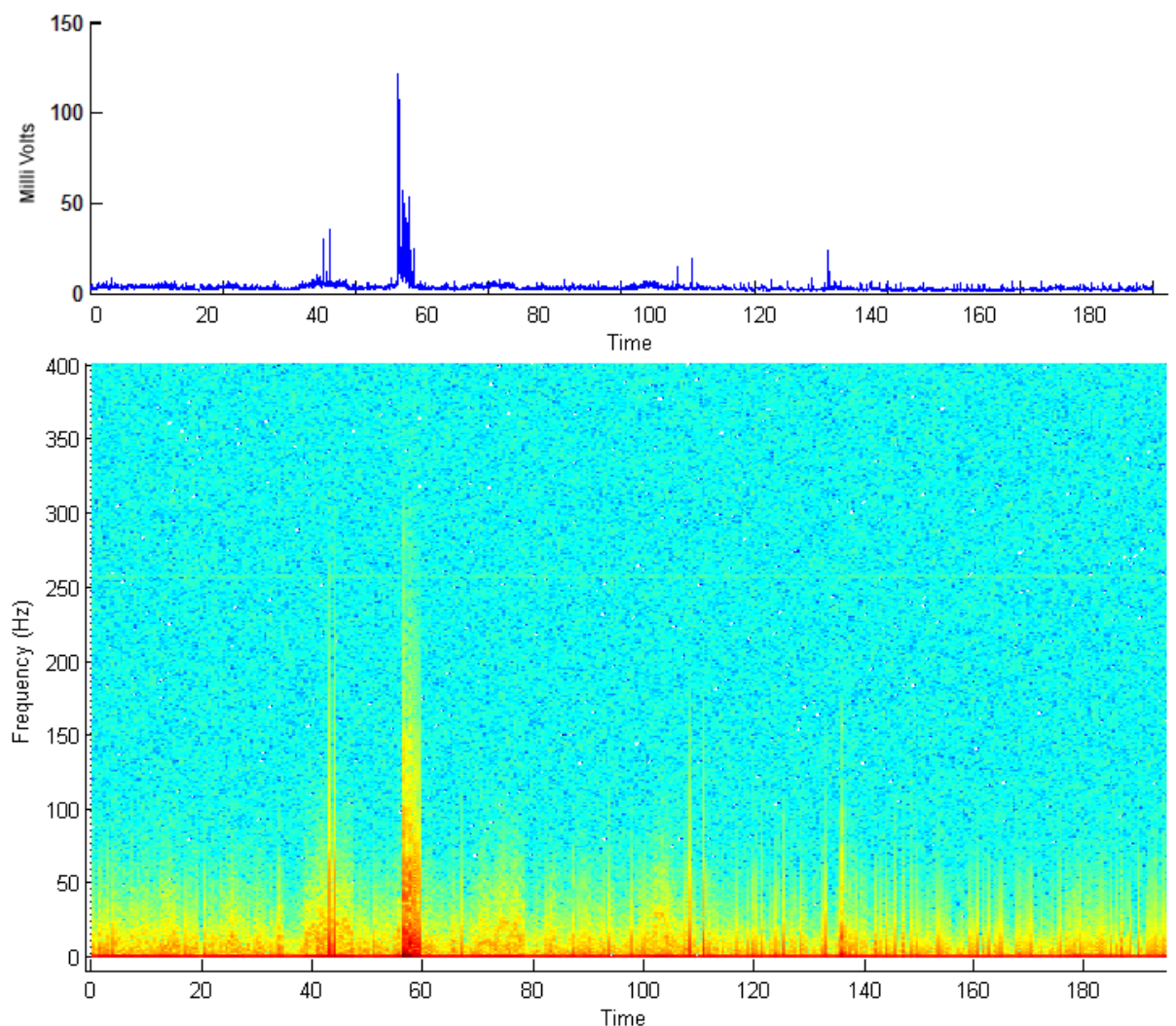

Figure 193: Time vs. Frequency domain EMG features; The lower graph is a spectrogram and the colouring is a third dimension indicating the amplitude of the given frequency (x) for the given time (y).

Several works (Phinyomark, Limsakul, & Phukpattaranont, 2009), and (Du & Vuskovic, 2004) suggested typical feature sets that could be extracted from sEMG

signals using a shifting window approach. A selection of feature sets described by the afore mentioned authors was chosen and implemented in Matlab in a way that builds upon the toolbox developed by Chan & Green (Chan & Green, 2007).

The feature sets being extracted for investigation in this work are:

- 1) Integrated EMG (IEMG);
- 2) Mean Absolute Value (MAV);
- 3) Weighted Mean Absolute Value 1 (WMAV1);
- 4) Weighted Mean Absolute Value 2 (WMAV2);
- 5) Mean Absolute Value Slope (MAVSLP);
- 6) Simple Square Integral (SSI);
- 7) Variance of EMG (VAR);
- 8) Root Mean Square (RMS);
- 9) Waveform Length (WL);
- 10) Slope Sign Change (SSC);
- 11) Willison amplitude (WAMP);
- 12) Autoregressive Coefficients (AR);
- 13) Median frequency (MDF);
- 14) Mean frequency (MNF);
- 15) Modified Median Frequency (MMDF);
- 16) Modified Mean Frequency (MMNF).

In the rest of this section we will examine each of these features. The examination will cover the mathematical definition of the feature and previous research efforts using this feature. We discuss the kinds of muscles each feature has been used with and any applicable classification tasks previously performed with the feature. We then show the distribution of the feature, by participant, when applied to our own data sets.

1) Integrated EMG (IEMG)

This feature is possibly one of the easiest to extract from the EMG signal. In this work it was calculated using Equation 13 as per Merletti & Torino, (1999). via a customised implementation derived from Chan & Green (2007)

$$IEMG = \sum_{n=1}^N |x_n|$$

Equation 13: IEMG Calculation, X is a window in the EMG signal of length N

Widely used in various EMG tasks, the IEMG has been used for emotion recognition and facial action classification tasks. A pioneering work (Sirota & Schwartz, 1982) used IEMG in studying Zygomatic and Corrugator activity and determined that facial EMG is sensitive to different emotional-states, even in subjects who report experiencing little or no subjective response to affective imagery and reveals differences in positive and negative emotions.

Further work using IEMG conducted by Hess,et al., (1989) and later by (Schmidt et al., 2006) was able to differentiate between deliberate and spontaneous smiles. These works principally used readings from the *zygomaticus major*, *depressor anguli oris*, *corrugator supercilii*, and *masseter*.

It should be noted that the term "Integrated EMG (IEMG)" is often used erroneously to describe a filtering technique known as "linear envelope detection". In an effort to rectify the situation, the International Society of Electrophysiology and Kinesiology made mention of the problem when creating a set of standards for reporting EMG data (Merletti & Torino, 1999).

Typical results of our algorithm are shown in Figure 194. An important aspect of the feature set is evident in this figure: namely large short isolated spikes in the data have little result in the final feature. The window size of one second was determined experimentally by visual inspection of the result, balancing accurate data representation against low response to noise and outliers.

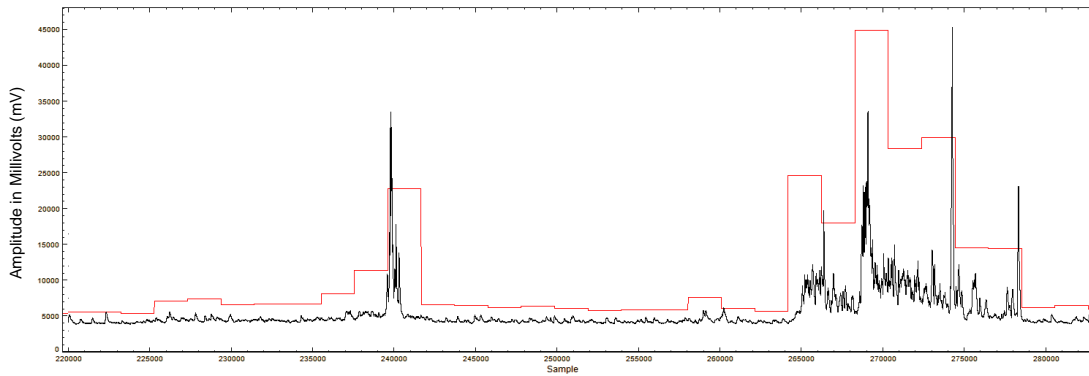

Figure 194: IEMG (window = 1s) feature extracted from experiment data. IEMG shown in red, EMG (not to scale) shown in black.

The distribution of this feature was studied in relation to the individual participants in the experiment (see Figure 195). Approximately 50% of participants exhibited a compact range of values for this feature, with maximum and minimum values falling within two standard deviations of the norm. Most participants had a negative skew in the response distribution. A notable exception was participant 28. This participant appeared to have an unusual presence of muscular activation.

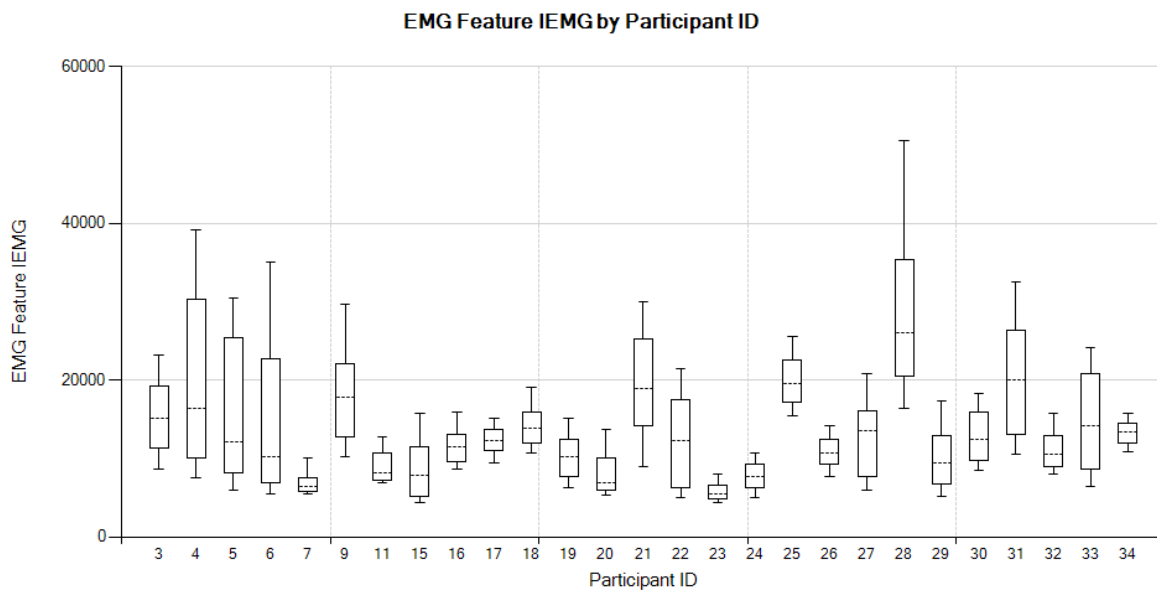

Figure 195: IEMG by participant

2) Mean Absolute Value (MAV)

Though a well-studied method of EMG feature extraction (Ben-Masaud et al., 2009), (Farthing, Borowsky, Chilibeck, Binsted, & Sarty, 2007), (Nathan, 2003), (Baratta et al., 1988), there appears to be no research in the field of emotion detection that mentions the use of the MAV feature. This feature (see Equation 14) appears to be commonly used in the study of muscle injuries, though evidence presented by (Huang, Zhou, Li, & Kuiken, 2009) shows that MAV can be used as a significant feature in EMG (kinematic) classification tasks in muscles of the arm and hand.

$$MAV = \frac{1}{N} \sum_{n=1}^N |x_n|$$

Equation 14: Calculation of MAV for a window (x) of size (N)

The distribution of this feature was studied in relation to the individual participants in the experiment. The results, shown in Figure 196, were very similar in distribution patterns to the IEMG distribution.

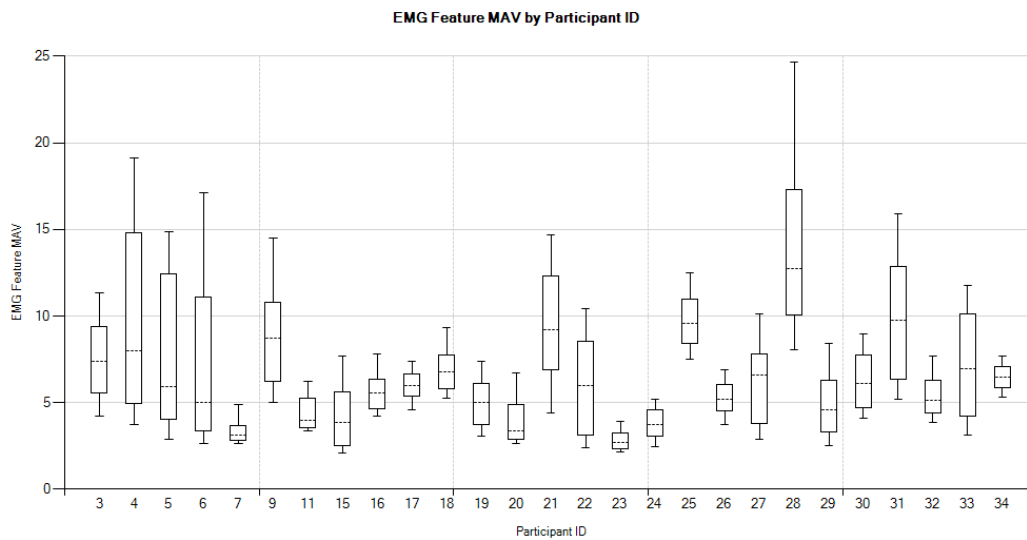

Figure 196: MAV by participant

3) Weighted Mean Absolute Value 1 (WMAV1)

This is a version of the Mean Absolute Value (MAV) with a simple windowing function. Advocated by (Phinyomark et al., 2009) (as the algorithm MMAV1) and given little attention as a specific feature in other literature, the feature is examined here for experimental purposes. The formula is presented in Equation 15.

$$WMAV1 = \frac{1}{N} \sum_{n=1}^N W_n |x_n|$$

$$\text{where } W_n = \begin{cases} 1, & 1/4 N \leq n \leq 3/4 N \\ 1/2, & \text{otherwise;} \end{cases}$$

Equation 15: Calculation of WMAV1 for a window (x) of size (N)

The distribution of this feature was studied in relation to the individual participants in the experiment. The results, shown in Figure 197, were very similar in distribution patterns to the IEMG distribution.

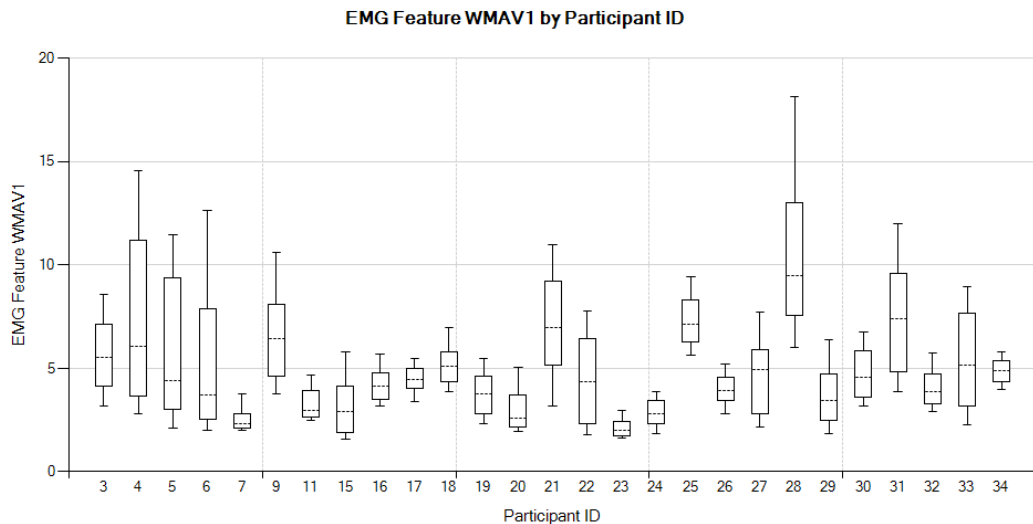

Figure 197: WMAV1 (MMAV) by participant

4) Weighted Mean Absolute Value 2 (WMAV2)

This is another version of the Mean Absolute Value (MAV) with an improved windowing function. Advocated by Phinyomark et al., (2009) (as the algorithm MMAV2) and given little attention as a specific feature in other literature the feature is examined here for experimental purposes. The formula is presented in Equation 16.

$$WMAV1 = \frac{1}{N} \sum_{n=1}^N W_n |x_n|$$

$$\text{where } W_n = \begin{cases} 1, & 1/4 N \leq n \leq 3/4 N \\ \frac{4n}{N}, & 1/4 N > n; \\ \frac{4(n-N)}{N}, & 3/4 N < n; \end{cases}$$

Equation 16: Calculation of WMAV2 for a window (x) of size (N)

The distribution of this feature was studied in relation to the individual participants in the experiment. The results, shown in Figure 198, were very similar in distribution patterns to the IEMG distribution

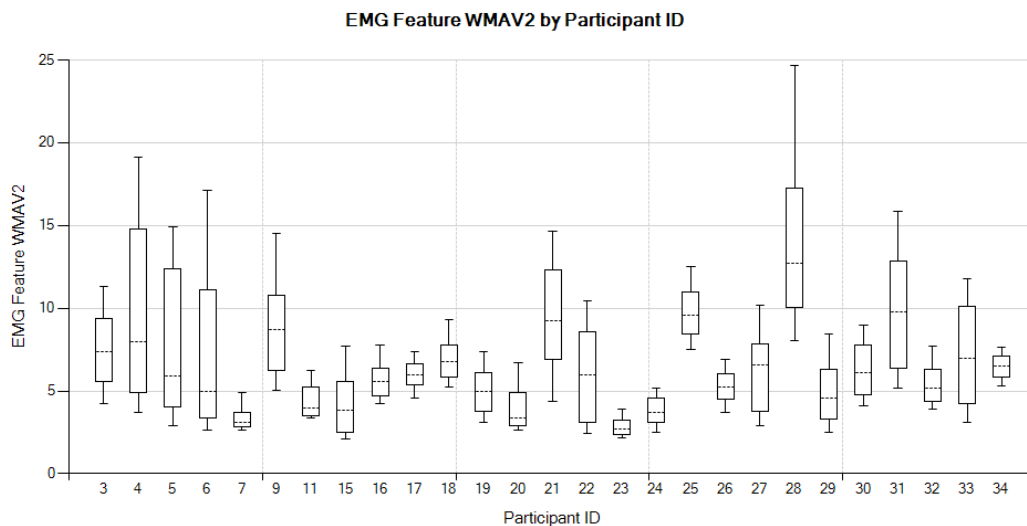

Figure 198: WMAV2 (MMAV2) by participant.

5) Mean Absolute Value Slope (MAVSLP)

This feature (see Equation 17) is used often in medical studies involving MAVSLP recognition for prosthesis control (Hudgins, Parker, & Scott, 1993). Hudgins et al., demonstrated classification tasks to achieve multifunctional prosthetic control using Mean Absolute Value Slope as a primary feature. To date there appears to be no emotion classification studies using this feature.

$$\text{MAVSLP}_n = \text{MAV}_{n+1} - \text{MAV}_n$$

Where:

$$\text{MAV} = \frac{1}{N} \sum_{n=1}^N |x_n|$$

Equation 17: Calculation of MAVSLP for a window (x) of size (N)

The distribution of this feature was studied in relation to the individual participants in the experiment. The results, shown in Figure 199, generally showed a standard distribution between 0.5 and 1.

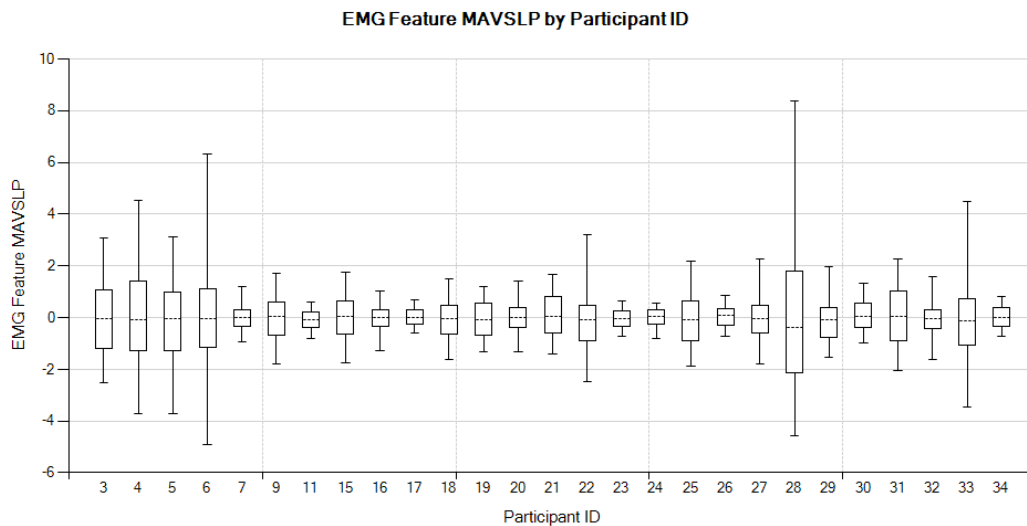

Figure 199: MAVSLP by participant.

6) Simple Square Integral(SSI)

The Simple Square Integral(SSI) (Phinyomark et al., 2009), is a feature which reflects the energy of the EMG signal for a given window. It is defined in Equation 18.

$$SSI = \sum_{n=1}^N (x_n)^2$$

Equation 18: Calculation of SSI for a window (x) of Size (N)

The distribution of this feature was studied in relation to the individual participants in the experiment. The data, shown in Figure 200, showed participant 28 had results significantly higher than any of the other participants.

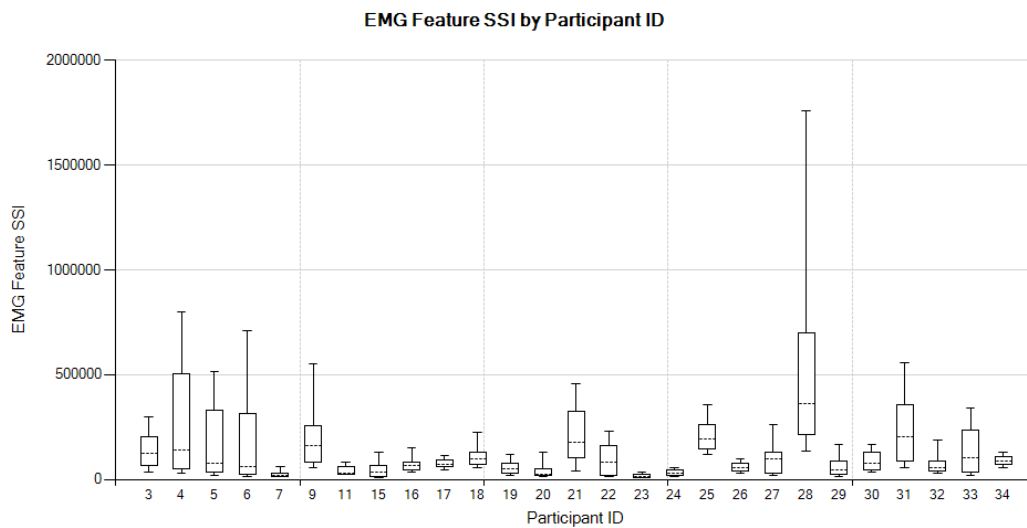

Figure 200: SSI by participant.

7) Variance of EMG (VAR)

The Variance of EMG (VAR) (Phinyomark et al., 2009) is a feature which reflects the power of the EMG signal for a given window. It is defined in Equation 19.

$$VAR = \frac{1}{N-1} \sum_{n=1}^N (x_n)^2$$

Equation 19: Calculation of VAR for a window (x) of Size (N)

The distribution of this feature was studied in relation to the individual participants in the experiment, as shown in Figure 201. The data was very similar to the SSI distribution, but in a different scale. Again participant 28 had results significantly higher than any of the other participants.

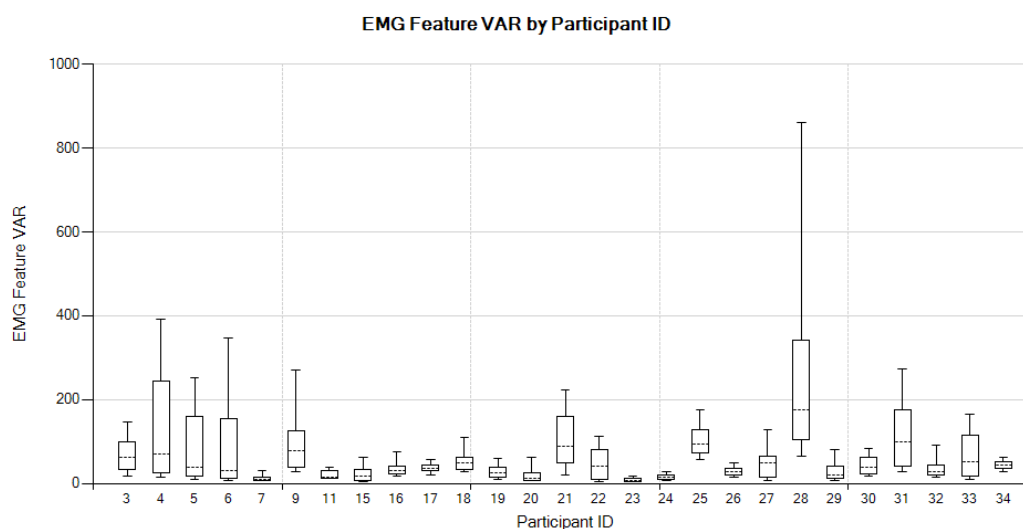

Figure 201: VAR by participant.

8) Root Mean Square (RMS)

The Root Mean Square (RMS) is a common statistical metric for measuring the magnitude of time series data. Its formulation is given in Equation 20.

$$RMS = \sqrt{\frac{1}{N} \sum_{n=1}^N (x_n)^2}$$

Equation 20: Calculation of RMS for a window (x) of size (N)

The distribution of this feature was studied in relation to the individual participants in the experiment, as shown in Figure 202. The data had a varied range of standard deviations for individual participants; ranging from around 1 at the lowest and 5 at the highest. Again participant 28 had results significantly higher than any of the other participants.

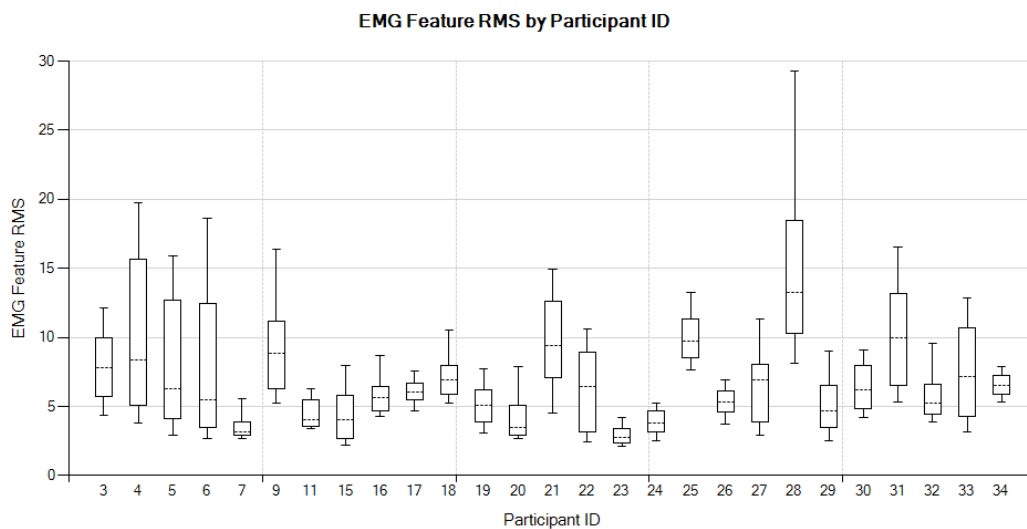

Figure 202: RMS by participant.

9) Waveform Length (WL)

The Waveform Length (WL) is the cumulative length of the EMG waveform over the window. This provides a combined measure of amplitude and frequency. It is defined in Equation 21.

$$WL = \sum_{n=1}^{N-1} |x_{n+1} - x_n|$$

Equation 21: Calculation of WL for a window (x) of size (N)

Evidence presented by (Huang, Zhou, Li, & Kuiken, 2009) shows that the WL was a significant feature in EMG classification tasks in muscles of the arm and hand.

Additionally Hudgins et al., (Hudgins et al., 1993) demonstrated classification tasks to achieve multifunctional prosthetic control using Waveform Length as a primary feature.

The distribution of this feature was studied in relation to the individual participants in the experiment, as shown in Figure 203. Participants 6 and 28 had results significantly higher than any of the other participants.

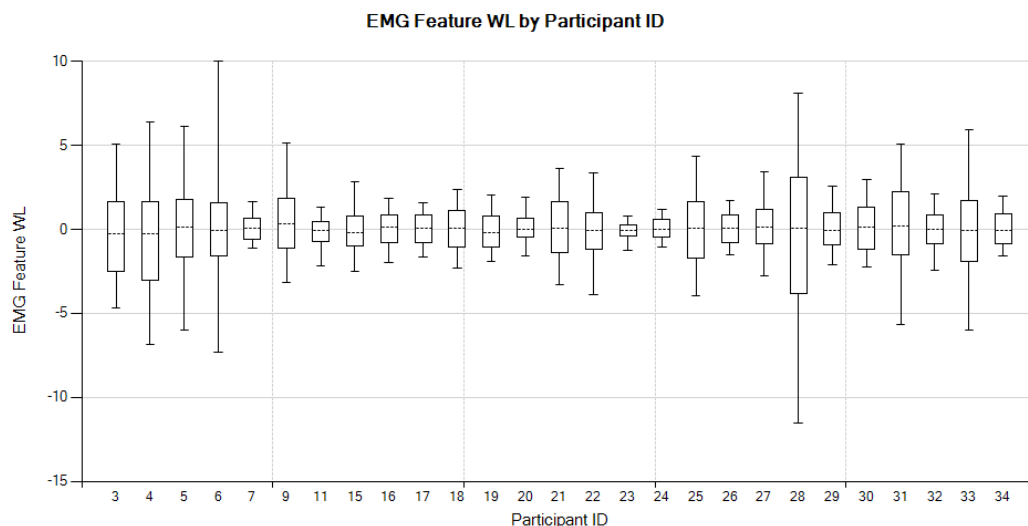

Figure 203: WL by participant.

10) Slope Sign Change (SSC)

The Slope Sign Change (SSC) is a method used to represent the frequency information of an EMG signal. The number of changes in slope, between positive and negative, in three consecutive segments is totalled. There is a thresh-holding function employed to reduce the effects of signal noise. The SSC is defined in Equation 22.

$$SSC = \sum_{n=2}^{N-1} f[(x_n - x_{n-1}) \cdot (x_n - x_{n+1})]$$

$$f(x) = \begin{cases} 0, & x < t \\ 1, & x \geq t \end{cases}$$

Equation 22: Calculation of SSC for a window (x) of size (N)

The threshold value used is generally between 10mV to 100 mV, in this case we use 100mV based on recommendations by Phinyomark et al., (Phinyomark et al., 2009). The distribution of this feature was studied in relation to the individual participants in the experiment, as shown in Figure 203.

Hudgins et al., (Hudgins et al., 1993) demonstrated classification tasks to achieve multifunctional prosthetic control using Slope Sign Changes as a primary feature.

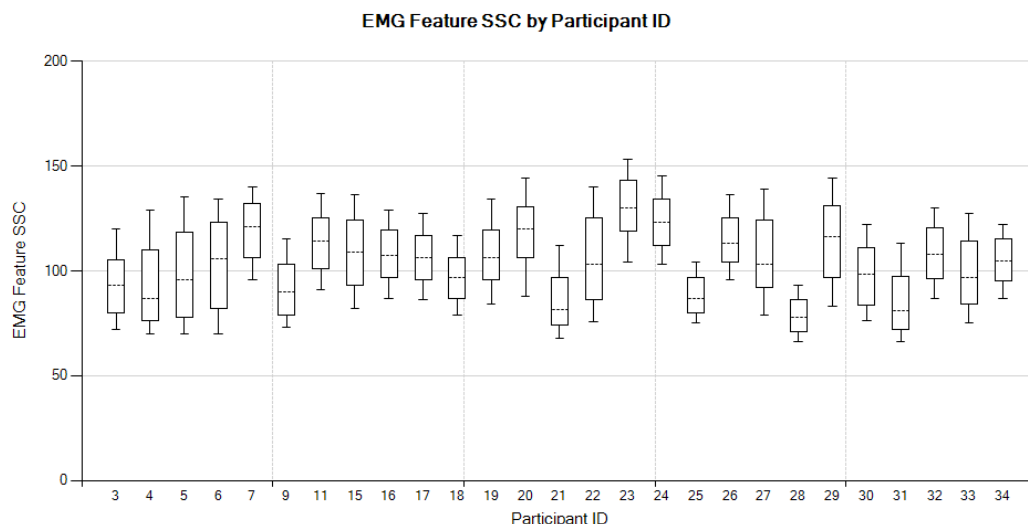

Figure 204: SSC by participant.

11) Willison amplitude (WAMP)

The Willison amplitude (WAMP) is a count of the number of times the difference between EMG signal amplitude among two adjacent segments exceeds a given threshold. The threshold in turn acts to reduce the effects of signal noise. The WAMP is defined in Equation 23.

$$WAMP = \sum_{n=1}^{N-1} f(|x_n - x_{n+1}|)$$
$$f(x) = \begin{cases} 0, & x < t \\ 1, & x \geq t \end{cases}$$

Equation 23: Calculation of WAMP for a window (x) of size (N)

The threshold value used is generally between 10mV to 100 mV, in this case we use 100mV based on recommendations by Phinyomark et al., (Phinyomark et al., 2009). The distribution of this feature was studied in relation to the individual participants in the experiment, as shown in Figure 205.

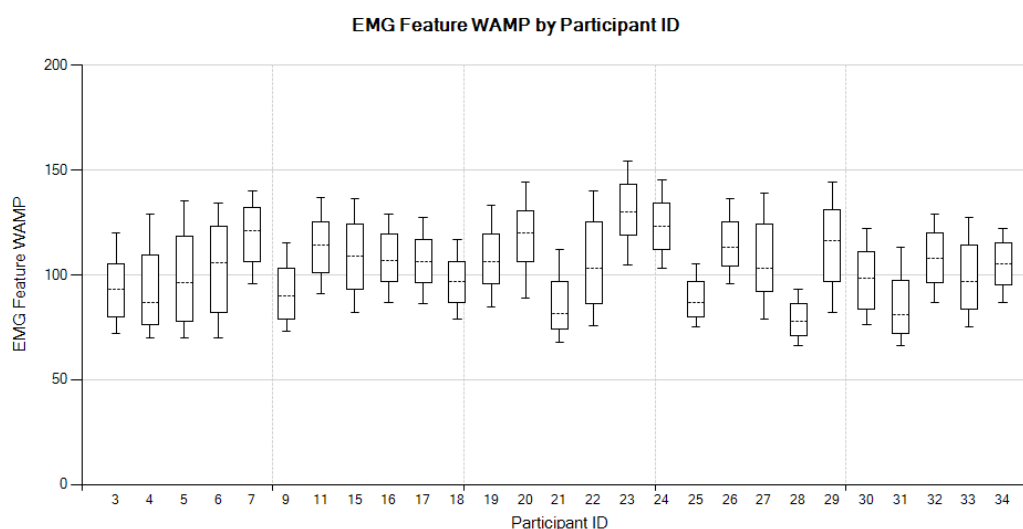

Figure 205: WAMP by participant.

12) Autoregressive Coefficients (AR)

The Autoregressive (AR) model describes each sample of the EMG as a linear combination of the preceding samples plus a white noise error term. The AR coefficients are calculated via the formula in Equation 24.

$$x_n = - \sum_{i=1}^p a_i x_{n-i} + w_n$$

where : x_n is a sample of the model signal,
 a_i is AR coefficients,
 w_n is white noise or error sequence,
 p is the order of AR model.

Equation 24: Calculation of AR Coefficients for a window (x) of size (N)

The autoregressive coefficients of orders 1 through 10 were computed using the Levinson-Durbin algorithm (Levinson, 1946) & (Durbin, 1973) as specified by (Shaman, 2010). Each order is treated as a separate feature extracted from the signal and our distributions for participants are shown in Figure 206.

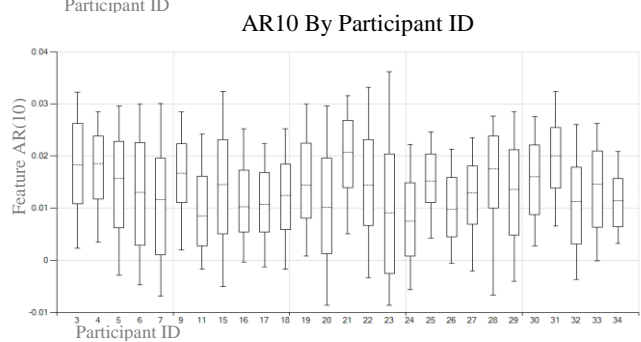
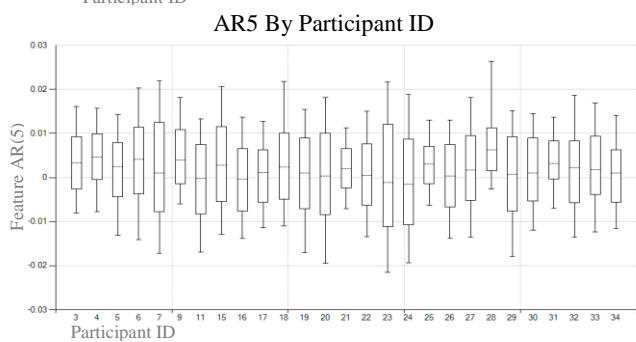
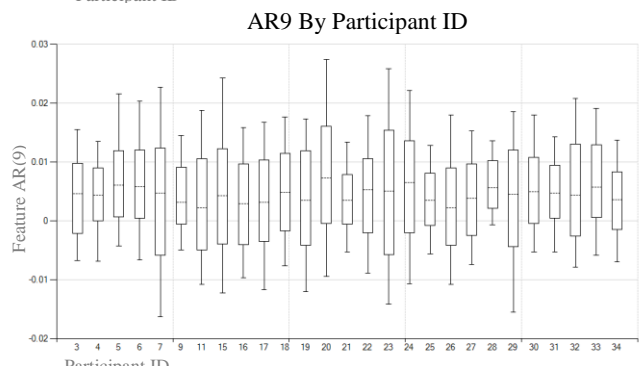
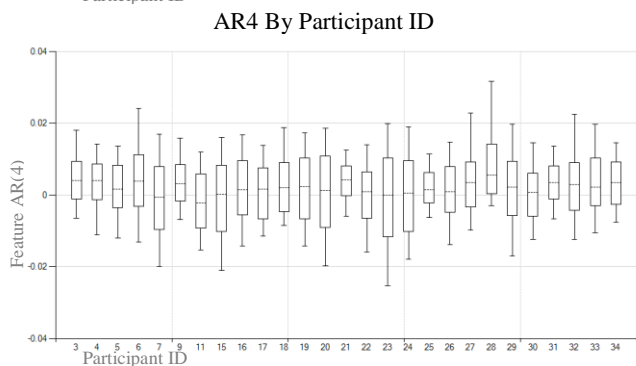
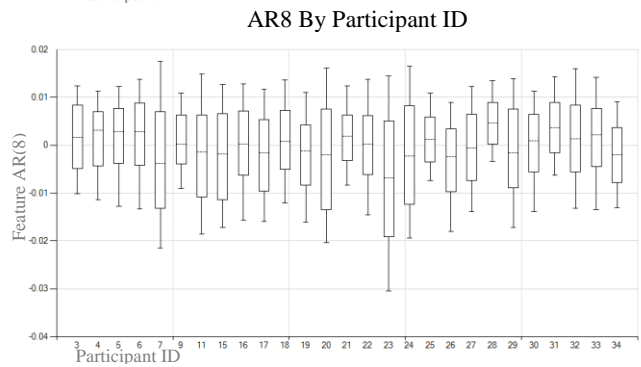
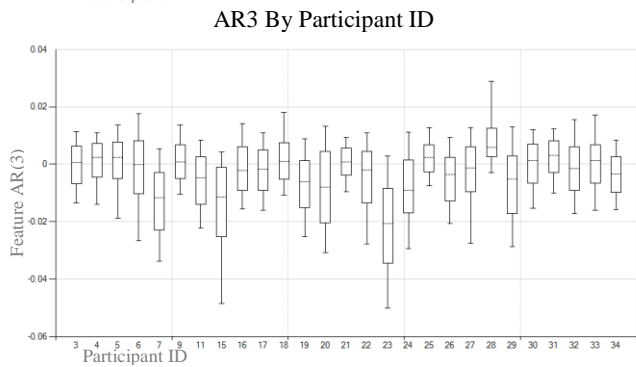
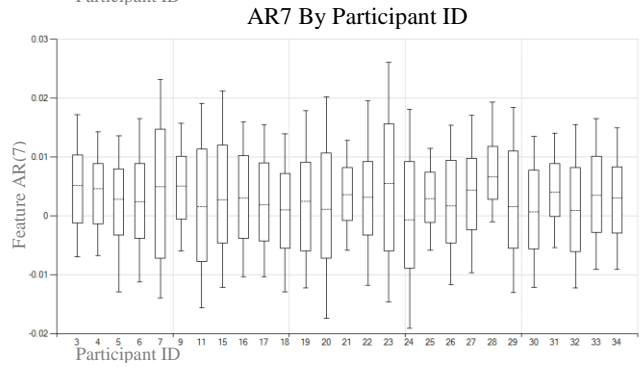
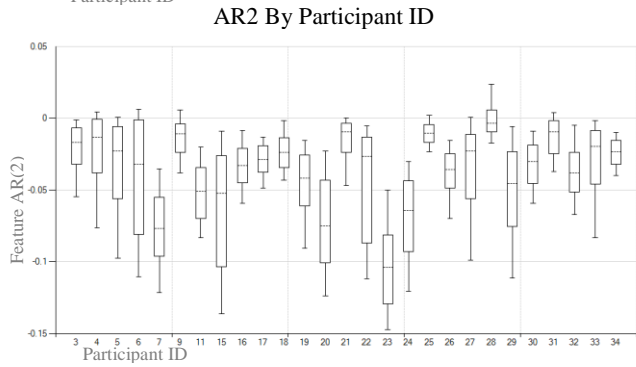
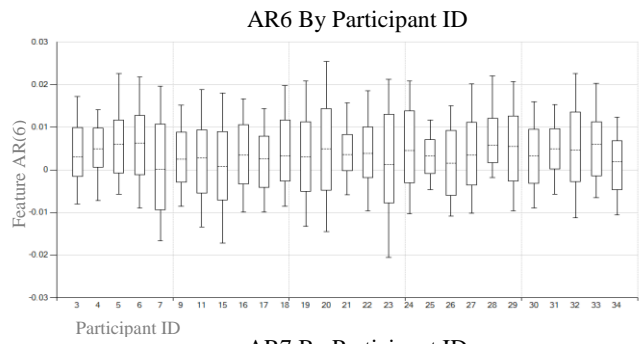
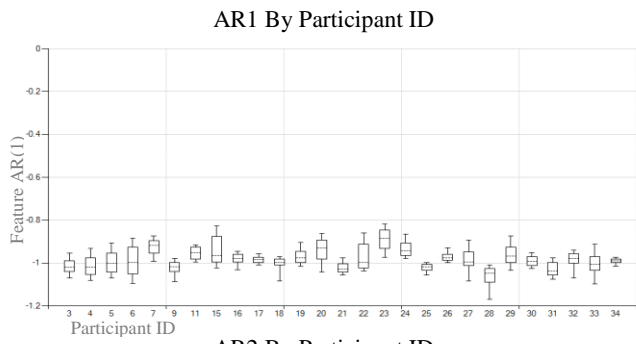

Figure 206: : Distribution of autoregressive coefficients 1-10.

13) Median frequency (MDF)

Median frequency is a feature often extracted in physiological signals, and used successfully in various works (Jordan, Stockmanns, Kochs, & Schneider, 2007), (Weitz, 2006). Median frequency is often reported as a highly variable measure and has been shown to relate in part to muscle fatigue (F. M. Azevedo et al., 2009).

The median frequency is the frequency at which the EMG power spectrum (P_j) is divided into two regions of equal amplitude. A typical power spectrum for one of our participants (entire signal) is shown in Figure 207.

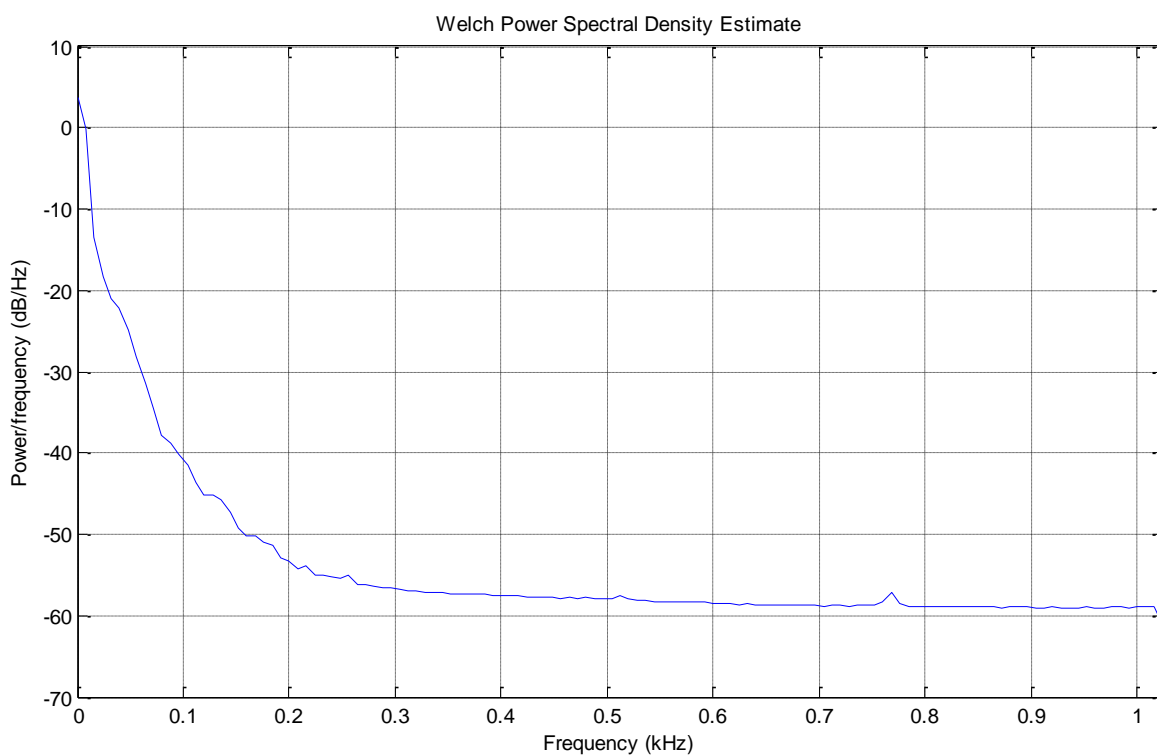

Figure 207: EMG Power Spectrum for a participant in our experiment.

The Median frequency is calculated using a binary search as per Equation 25.

$$\sum_{j=1}^{MDF} P_j = \sum_{j=MDF}^M P_j = \frac{1}{2} \sum_{j=1}^M P_j$$

Equation 25: Calculation of MDF from power spectrum P_j

A distribution of this feature for our participants is given in Figure 208, participants 6 and 28 had the broadest range.

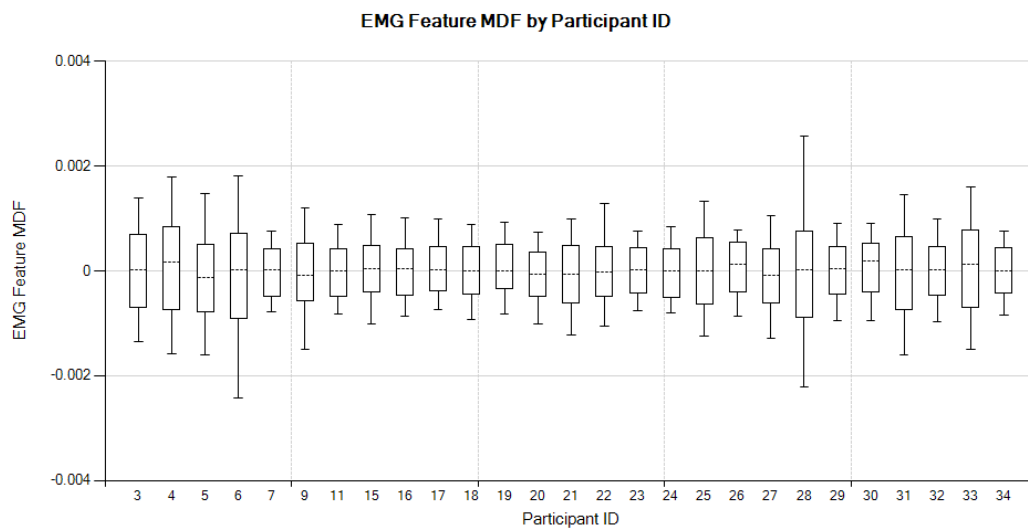

Figure 208: Median Frequency Distribution (MDF), by participant

14) Mean frequency (MNF)

The mean frequency is often studied alongside the median frequency and has a similar statistical significance. The equation is given below and the distribution in our population is given in Figure 209. The resulting distribution is given in Equation 26.

$$MNF = \frac{\sum_{j=1}^M f_j P_j}{\sum_{j=1}^M P_j}$$

Equation 26: Calculation of MNF from power spectrum P_j and corresponding frequency f_j .

The distribution of this feature was studied in relation to the individual participants in the experiment, as shown in Figure 209. Participants 6 and 28 had results significantly higher than any of the other participants.

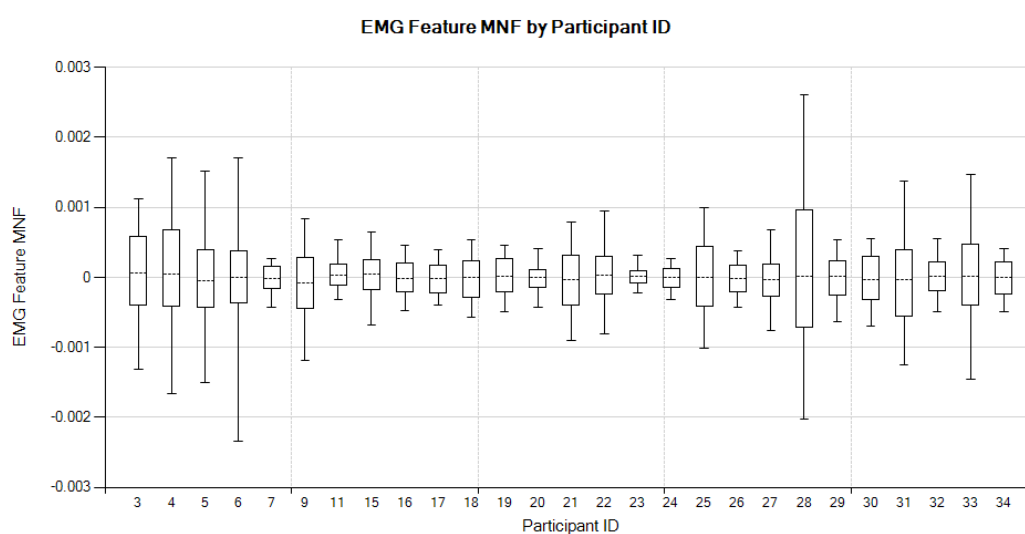

Figure 209: Mean Frequency Distribution (MNF), by participant.

15) Modified Median Frequency (MMDF)

The Modified Median Frequency, also called the Median Amplitude Frequency is a variation of the MDF calculated using the amplitude spectrum rather than the power spectrum. The metric was presented as a novel feature by Phinyomark et al., (Phinyomark et al., 2009) and compared to other traditional EMG features. The studies finding showed that this feature was useful as part of a multi feature classification system, but proposed a Modified Mean Frequency feature which showed a more statistically significant role in classification accuracy. The equation for this metric is shown in Equation 27.

$$\sum_{j=1}^{MMDF} A_j = \sum_{j=MMDF}^M A_j = \sum_{j=1}^M A_j$$

Equation 27: Calculation of MMDF from amplitude spectrum A_j

The distribution of this feature was studied in relation to the individual participants in the experiment, as shown in Figure 210. Participants 6 and 28 had results significantly higher than any of the other participants.

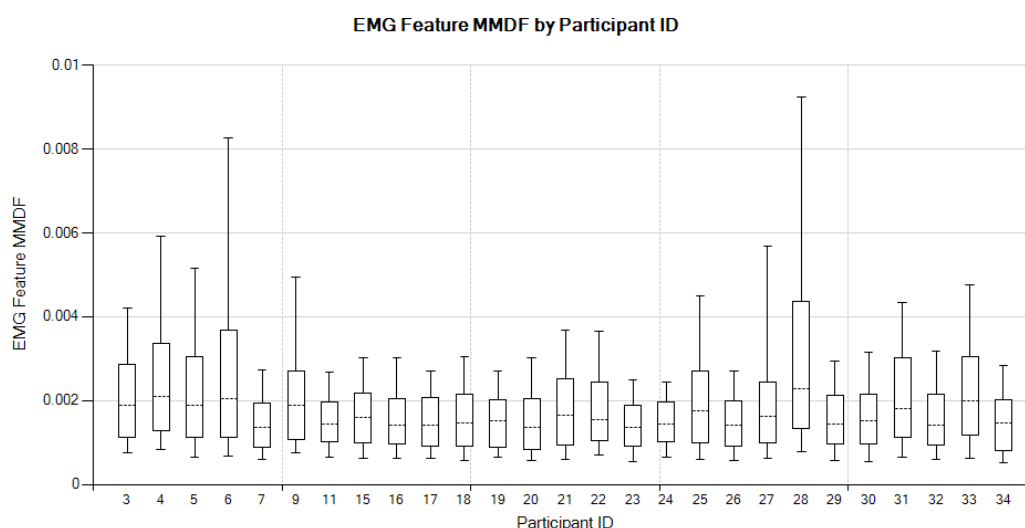

Figure 210 Modified Median Frequency Distribution (MMDF), by participant.

16) Modified Mean Frequency (MMNF)

The Modified Mean Frequency, also called the Mean Amplitude Frequency is a variation of the MNF calculated using the amplitude spectrum rather than the power spectrum. The metric was presented as a novel feature by Phinyomark et al., (Phinyomark et al., 2009) and compared to other traditional EMG features. The study's findings showed that this feature was statistically significant in terms of classification accuracy of EMG. Their task was predicting voluntary hand movements given forearm EMG signals.

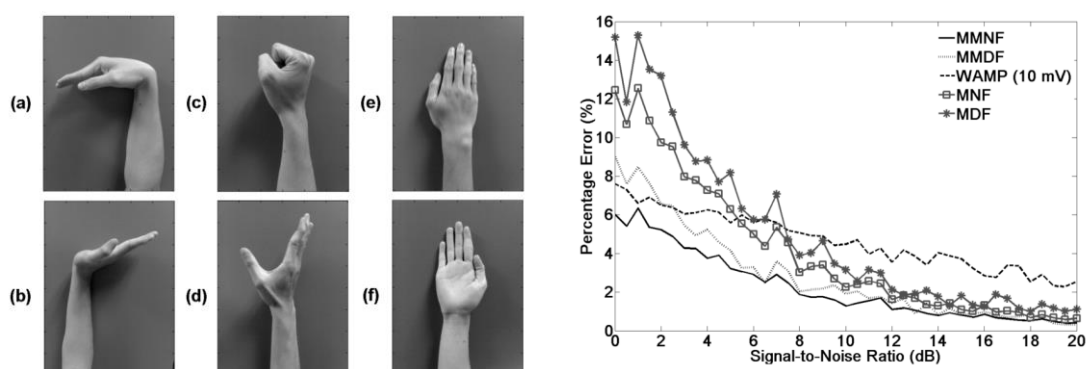

Figure 211: Performance of MMNF (Phinyomark et al., 2009)

The formula for MMNF is given in Equation 28, and the resulting distribution in our population is shown in Figure 212.

$$MMNF = \frac{\sum_{j=1}^M f_j A_j}{\sum_{j=1}^M A_j}$$

Equation 28: Calculation of MMNF from the amplitude spectrum A_j and corresponding frequency f_j

The distribution of this feature was studied in relation to the individual participants in the experiment, as shown in Figure 212. Participants 6 and 28 had results significantly higher than any of the other participants.

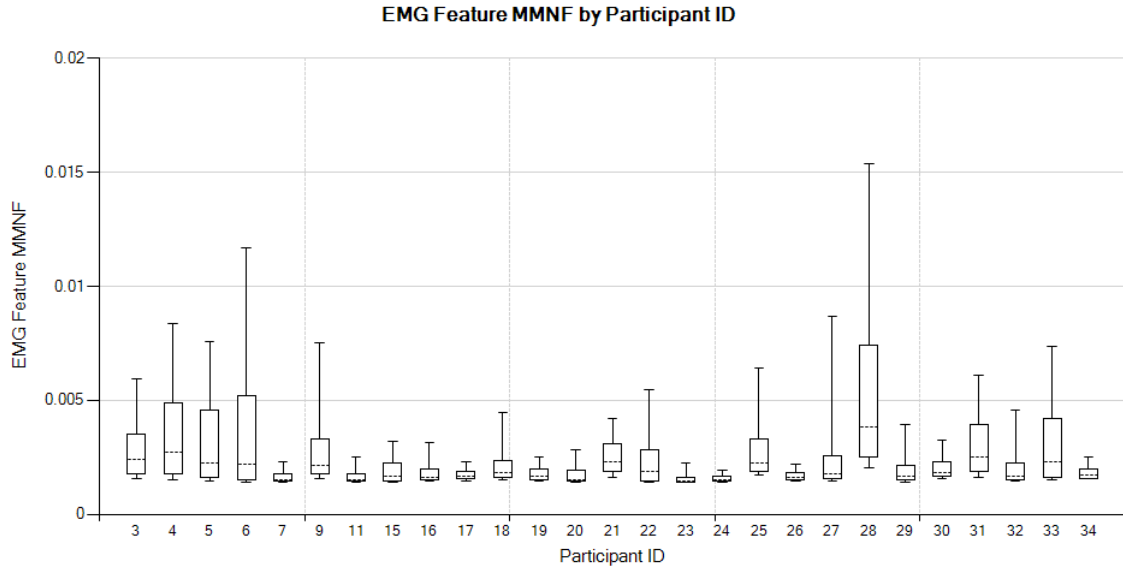

Figure 212: Modified Mean Frequency Distribution (MMDF), by participant

9.2.2. Artefact Detection

Artefact detection was generally not needed as our EMG sensor remained well connected. This was due to good adhesive pads and a favourable performance of the couplings during data collection; typically there is no method to completely avoid the occasional contact problems in surface EMG electrodes. We did use simple thresholding at 0.3mV to detect artefacts such as those present while verification of proper sensor placement was being made. Typical results are shown in Figure 213. This thresholding level was determined by visual inspection of the data.

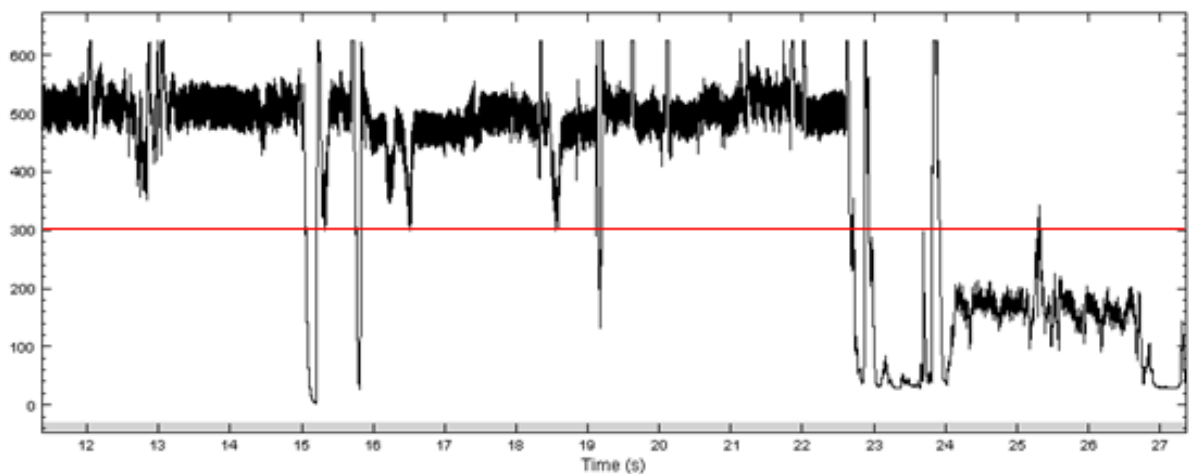

Figure 213: EMG artefact detection by thresholding at 0.3mV. The portion of the signal with significant activity above the red line was caused by an artefact. After 23 seconds the sensor placement was corrected.

9.3 Skin Temperature

Skin temperature is a signal often studied in experiments involving human physiology. Skin temperature is controlled by the hypothalamus. It is linked to the control of internal temperature and the effects of ambient external temperature in a system known as the human thermoregulatory response. It is necessary to distinguish the human response as opposed to other animals and mammals as thermoregulatory systems are greatly varied between species.

Skin temperature may be subject to external factors, but is to some degree controlled by the human body via several physiological mechanisms:

- Vasoconstriction can decrease the blood flow to the skin, minimising heat loss to radiation;
- Sweating, to evaporatively cool the skin, and body via blood flow;
- Shivering to increase heat production in the muscles;
- Release of epinephrine, norepinephrine, and thyroxine to increase metabolism and thus heat production;
- The erection of the hairs to increase insulation.

The temperature sensor gives a highly aliased result whereby the quantisation levels cause a jittered signal that is problematic for further processing, such as slope detection algorithms. This problem was initially overcome using a Savitzky-Golay (Savitzky & Golay, 1964) smoothing filter with a window of 1.02Hz and a polynomial order of two to reduce the aliasing. A typical result is shown in Figure .

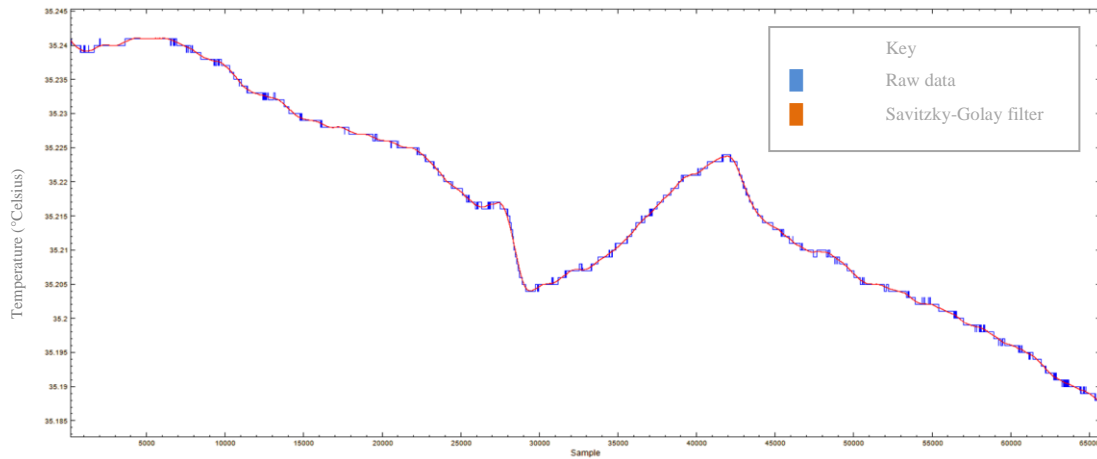

Figure 214: Savitzky-Golay filter on skin temperature data

The Savitzky-Golay filter proved an adequate method to filter the data; however it was improved slightly by using a median filter to pre-process out small spikes. Pre-processing the data with a median filter, using a window of 10ms, prior to the smoothing effect of the Savitzky-Golay filter provided a cleaner result. A result indicative of this improvement is shown in Figure 215.

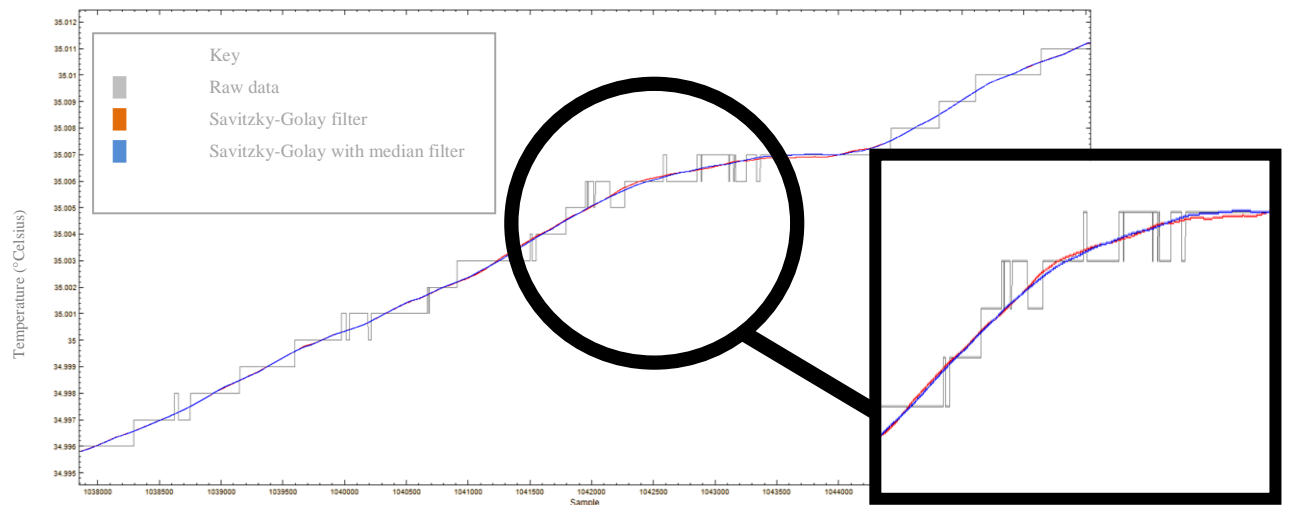

Figure 215: Effect of pre-processing with a median filter

Applying the Savitzky-Golay filter to the median filtered data allows the median filter to remove the small "jaggies" which would otherwise bias the polynomial regression Savitzky-Golay filter. This gives a good result that, for many purposes, may be unnecessarily refined and computationally wasteful.

There are not many features typically extracted from the temperature signal and most of the studied features are time domain based.

Normalising temperature data is something often considered a trivial task. Often studies such as Zhai & Barreto (Jing Zhai & Barreto, 2006b) will take a baseline reading of a user's skin temperature during an experiment's acclimatisation and instructional period. This base line is averaged and all recordings for the experiment are then normalised against this average.

Our work attempts to make the temperature data more invariant per person by correcting for some external factors influencing skin temperature. As skin temperature variations and responses are effected by individual characteristics, diurnally by time of day, environmentally and affectively by both mood and emotion; which results in a non-trivial variance being present in recorded values. The following is a description of our experimental results, related research and a proposal for the normalisation of skin temperature data in a completely invariant manner.

9.3.1. **Skin Temperature Alteration by Mood and Medium Term Trends**

In our experimental setup there was no temperature difference in the waiting room where people rested prior to the experiment and the experimental environment itself. Participants were given ample time (approx 15 minutes) to settle into the new environment of the testing room. The sole control of the buildings airconditioning system was given to (taken by) the research staff involved in the experiment.

Despite these precautions, long term (in our case this means several minutes) skin temperature variations were present in most of our subjects. Typical results are shown in Figure 216. Note how a baseline taken during the instructional period would not be appropriate.

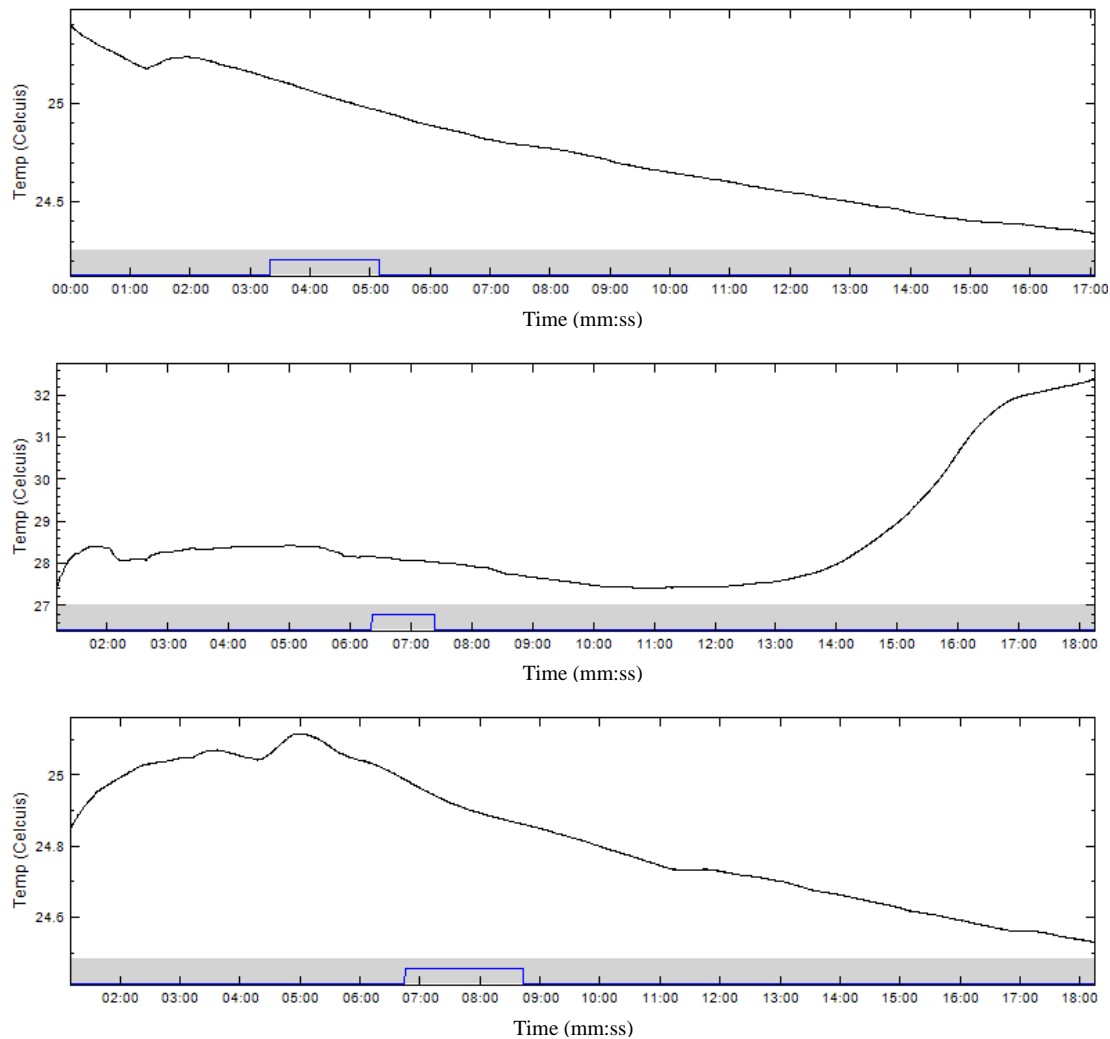

Figure 216: Medium term skin temperature trend (three worst participants shown, to highlight problem), lower trace indicated the duration of the training period.

In our experimental setup, the stimulus was applied to the participant for six seconds. Early research from Mittelman & Wolff (Bela Mittelman & Wolff, 1943) showed that skin temperature was related to emotional state by taking skin temperature recordings of a patient undergoing psychiatric counselling. Mittelman & Wolff were able to show that the prevalent mood of some of their subjects, such as depression or a feeling of reassurance, could readily be correlated with their skin temperature recordings. Some of their results are shown in Figure 217 and Figure 218. Notice that the trends are a medium term response (5 to 10 minutes).

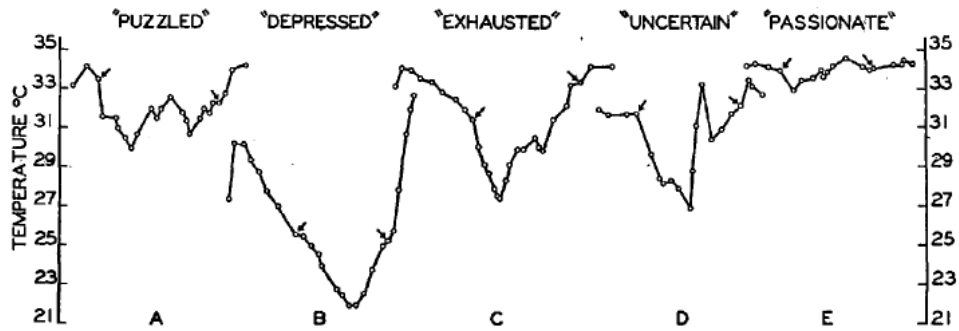

Figure 217: Finger temperature curve during a series of depressive reactions. (Bela Mittelmann & Wolff, 1943)

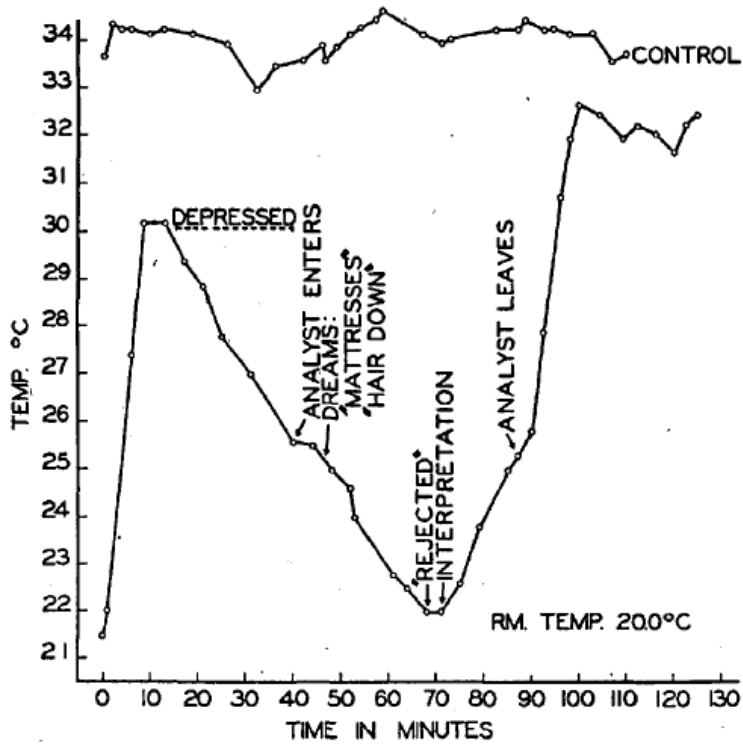

Figure 218: Typical skin temperature variation during a psychiatric interview (Bela Mittelmann & Wolff, 1943) ['RM TEMP' appears to be an error]

9.3.2. A Skin Temperature Feature Extraction Method

We recognise that there may be flaws in using a rest period as a baseline measurement for temperature data, but are unable to resolve these issues, so we proceeded with a baseline driven technique. The results are shown in Figure 219.

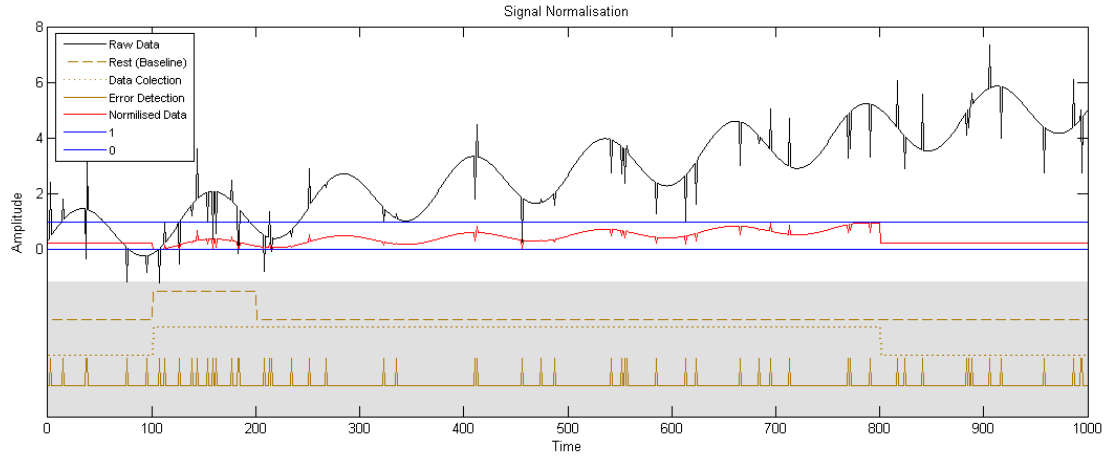

Figure 219: Normalisation method for skin temperature, shown on synthetic data. The red line showing normalised data had its baseline established during the period before the experiment started, while the participant was sitting in the chair and the electrodes connections were verified.

A skin temperature metric was created by calculating the mean absolute value (Equation 29) of the signal using a sliding window of 128ms.

$$MAV = \frac{1}{N} \sum_{n=1}^N |x_n|$$

Equation 29: Mean Absolute Value (MAV) calculation

9.4 Respiration

In this section we cover the features extracted from the respiration signal using a variety of peak detection, area under curve and slope measuring techniques. We outline issues with peak finding and paused breaths.

Finding the respiration rate is achieved by finding peak values from the respiration sensor and measuring the time between them. These peaks are recorded when the chest is no longer expanding and the exhale process begins. These peaks are not sharp and this is an issue. Many peak detection algorithms, such as the ones provided by Matlab (“MATLAB,” 2003) do not function well for peaks that have a plateau at the top.

We employed a peak detection algorithm by O’Haver (O’Haver, 2009). This algorithm is based on classical first derivative y-axis crossing to find peaks, but adds smoothing and detection thresholds. Typical results shown on our respiration data are shown in Figure 220. This algorithm was essential as it detected smooth top peaks correctly; and many other algorithms do not.

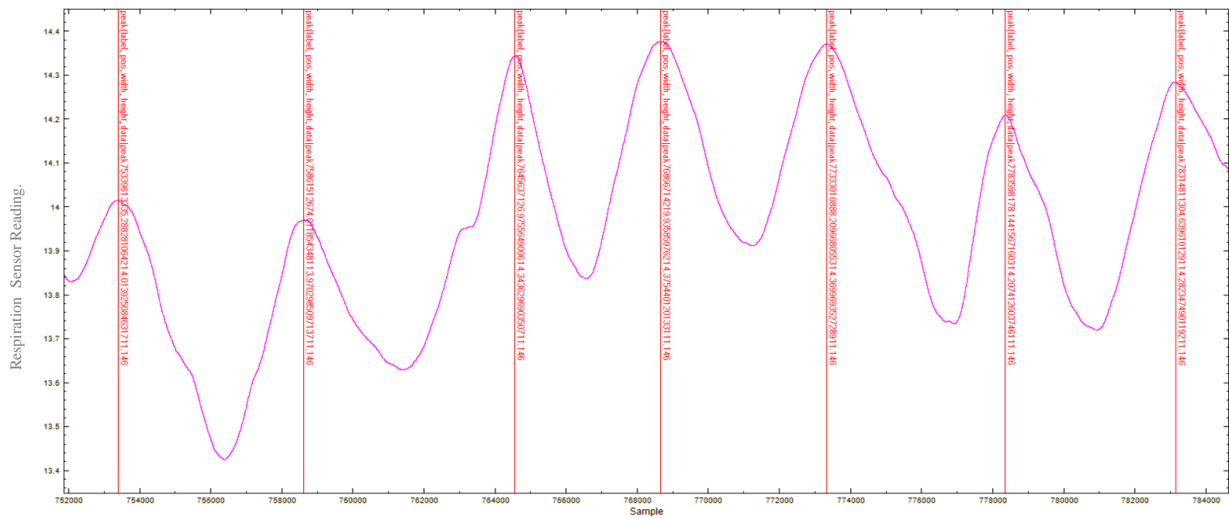

Figure 220: Peak detection of respiration data. Each red line is a detected peak.

We tuned the detection algorithm to ignore minor peaks that were part of a larger break, see Figure 221. We encountered many of these peaks which are the result of a pause in breathing.

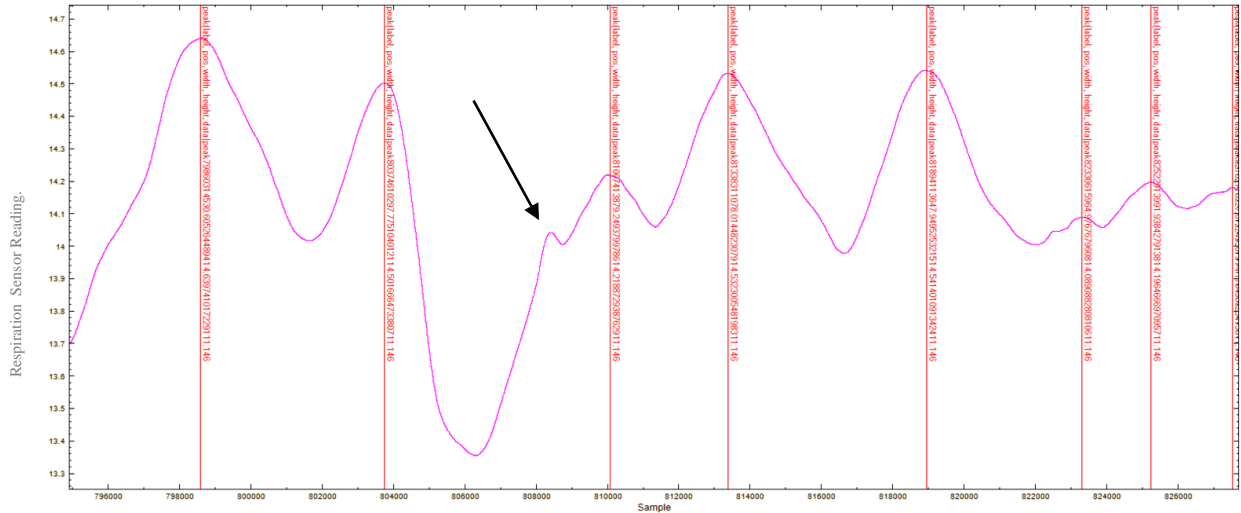

Figure 221: Interrupted breath. The peak shown by the arrow appears to be made by some sort of pause in the regular breathing cycle.

Note our observations are linked to our use of the higher chest placement. Other researchers using a lower chest placement will have a different signal, an example of this is shown in Figure 223.

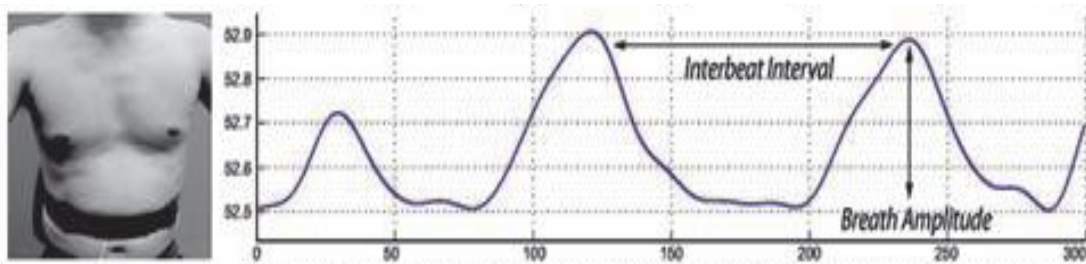

Figure 222: The signal obtained from a lower chest placement of the respiration sensor.

The work by O'Haver (O'Haver, 2009) produced other metrics such as peak widths and amplitudes. We sorted this data into inhale and exhale pairs and created another metric to provide an approximation of slope. Results are shown in Figure 223.

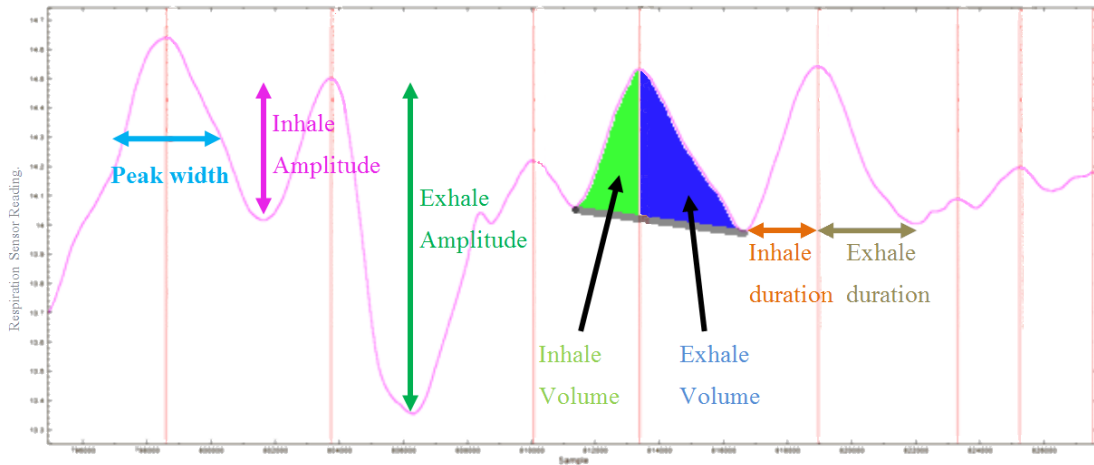

Figure 223: Respiration metrics. The coloured regions are used in a slope approximation function.

The curve of the respiration signal has some non-trivial components as the curve is often inflected or contains a separate local peak. We created a metric related to the morphology by defining a rectangle between the peak minima/maxima. The metric was calculated by finding the percentage of the rectangle which exists under the respiration curve. This process is shown visually in Figure 224.

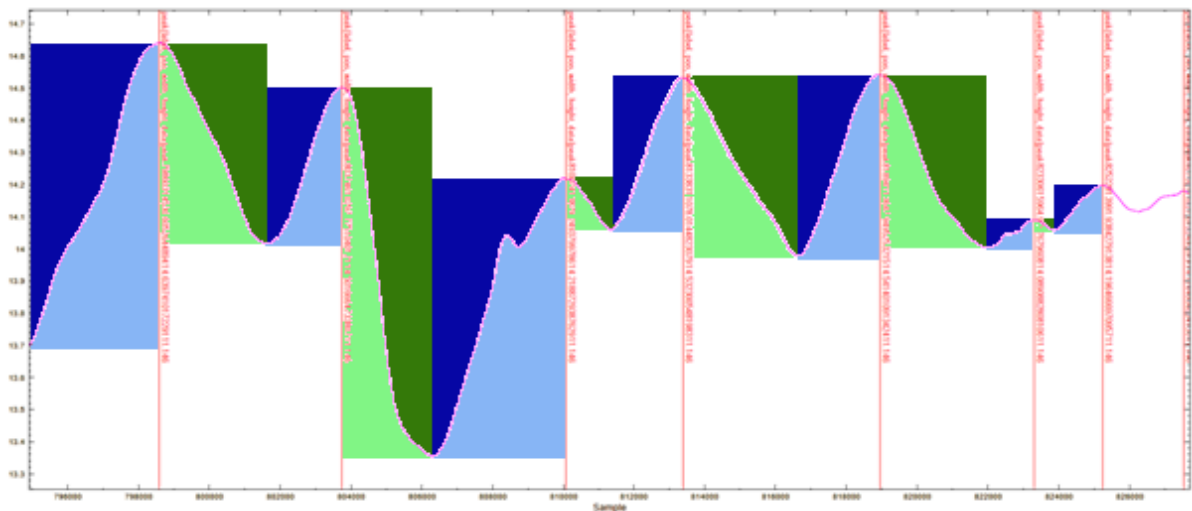

Figure 224: Curve metric function. The metric for any of the sections shown is the area under the curve divided by the size of the box. A dark/light blue box is shown for inhalation and a dark/light green box is shown for exhalation.

This curve metric will be 0.5 in the case of a straight line. Curves with more concave morphology will be in the range 0.5 to 1. Convex morphology, on the other hand, will be in the range 0 to 0.5. A synthetic example is shown in Figure 225.

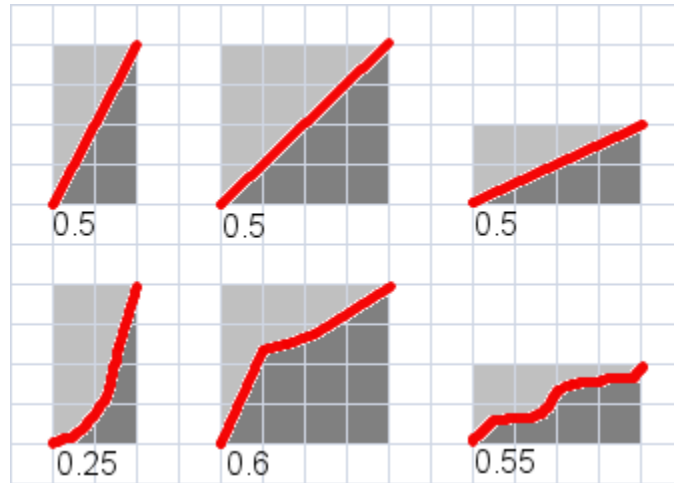

Figure 225: Curve metric in synthetic form.

9.5 Blood Volume Pulse

The BVP signals can be obtained using a pressure sensor or an optical sensor, this produces two different waveforms as per Figure 226. Our work used an optical sensor which meant processing a repetitive signal with multiple peaks per waveform. We constructed a set of novel features for this work which we present in this section.

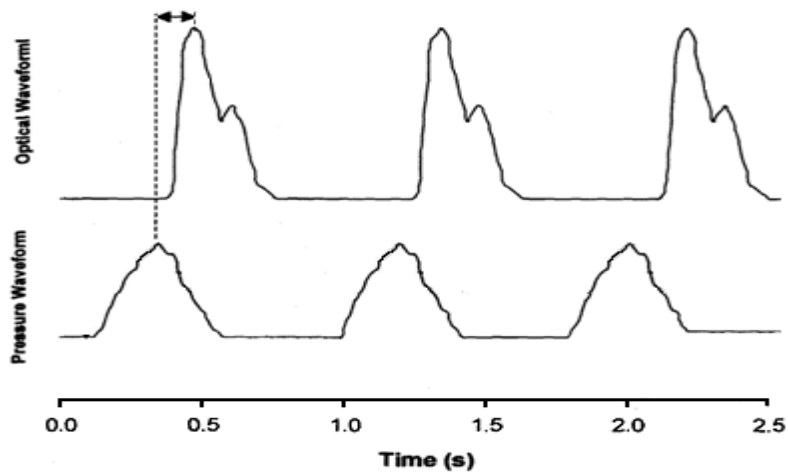

Figure 226: Reference image of BVP Waveforms Pressure vs. Optical

Our typical waveforms are shown in Figure 227. The signal was typically clean and smooth. The sensor was prone to physically slipping off the participant's finger; this created many artefacts which were removed from the experiment by simple amplitude thresholding.

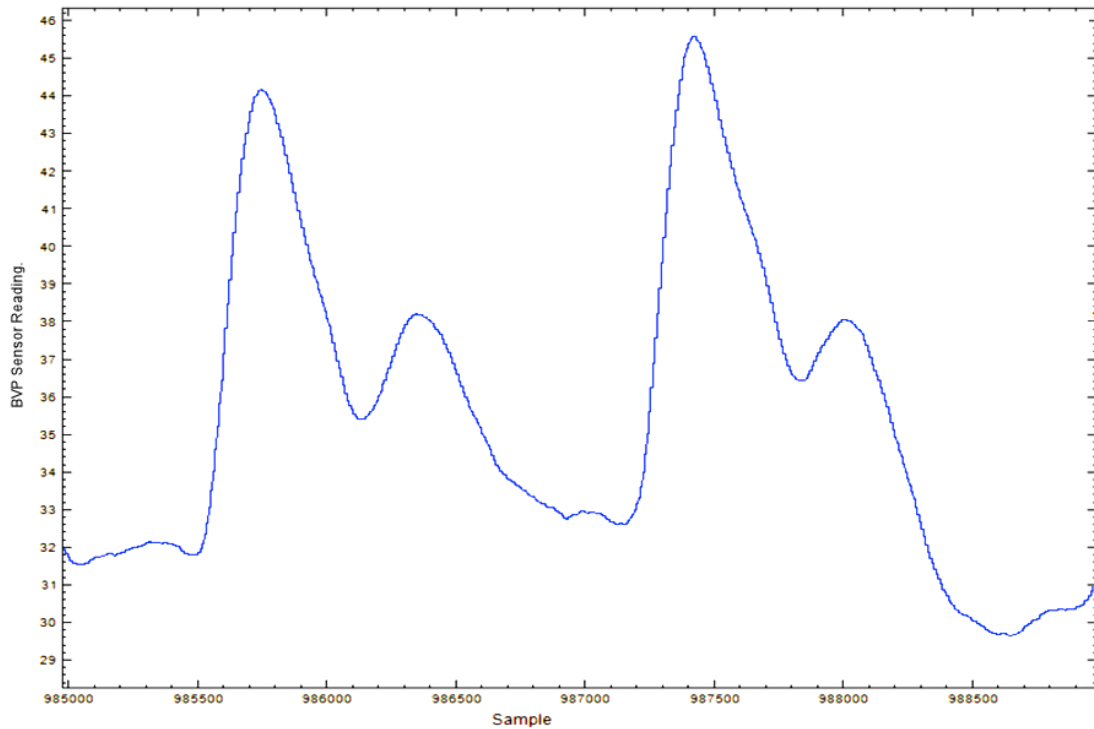

Figure 227: Typical BVP waveform collected during our experiment.

The BVP is related to the ECG and they are often used to complement each other's signal processing. We did not elect to do this for this work. The expected visual correlations between ECG and BVP were verified however and are shown in Figure 228.

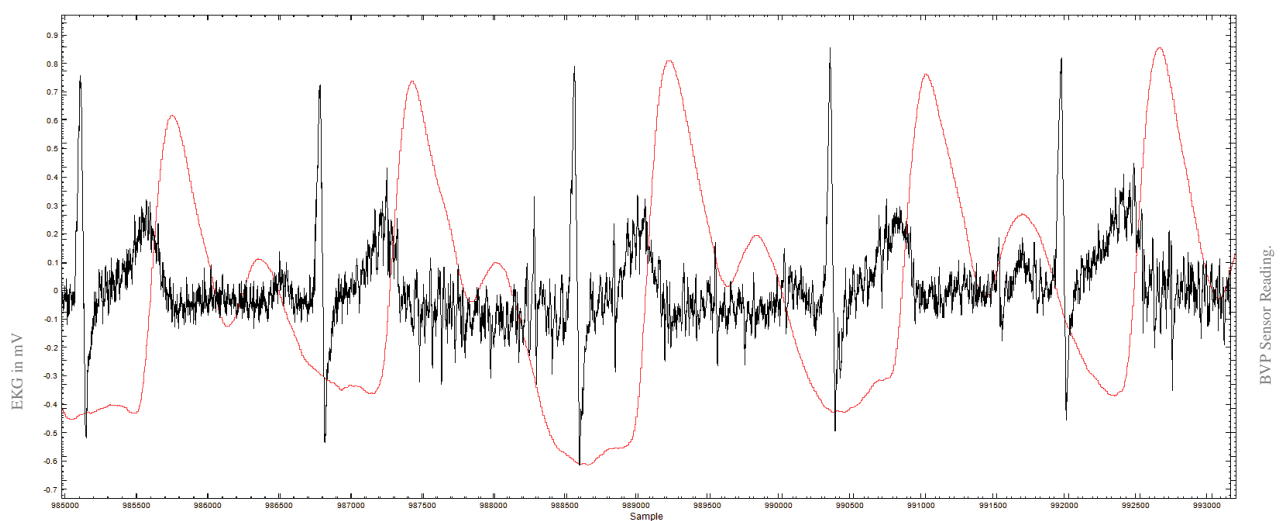

Figure 228: ECG and BVP signals for the same participant.

To find and separate the different peaks present in this wave form, we performed peak detection twice. The first round only detects the larger peaks, to get the location of the major waves. The process is run again with a lower peak height threshold and subsequent peaks, that were not detected previously, are determined to be minor. Occasionally a third minor peak (or dent) is detected and removed. A typical example of all these situations is shown in Figure 229.

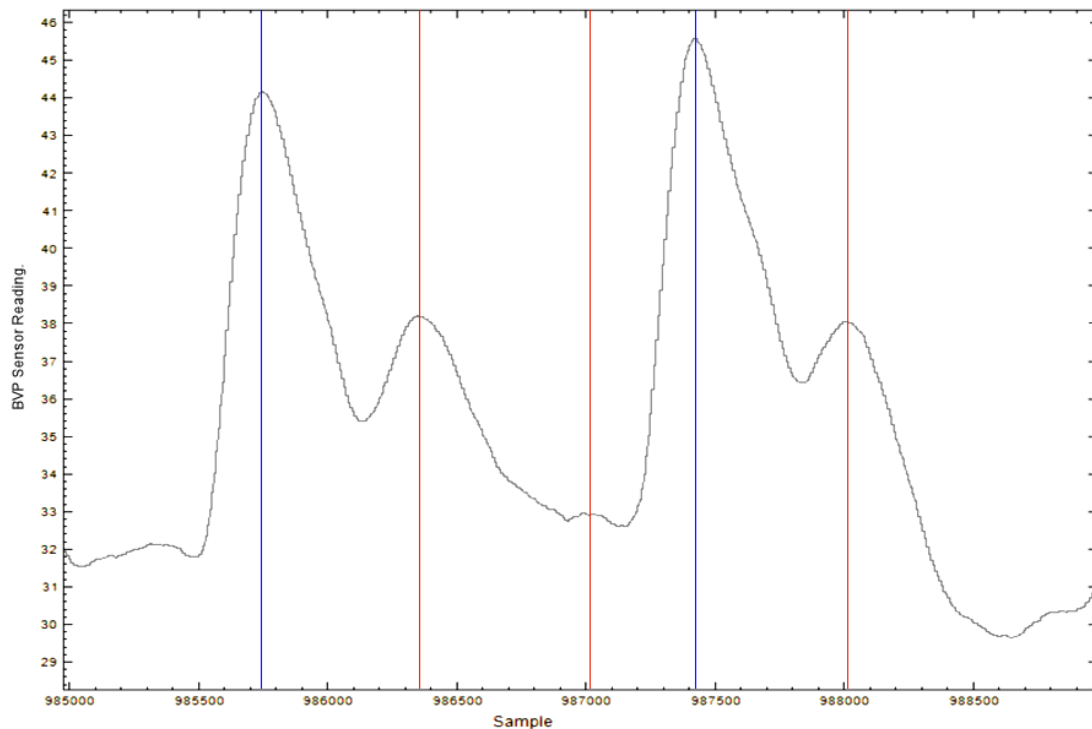

Figure 229: BVP waveform peaks. Major peaks in blue, minor peaks in red.

9.5.1. Features Extracted

As both signals are semi-irregular periodic waveforms, we reuse the feature set discussed for the respiration signal for the BVP signal. However, in this case features of major peaks are measured in regards to the next major valley (skipping minor peaks). This is done to get a reading of the overall heart action. This application also highlights the strength of our slope metric on these complex morphologies. Typical results are shown in Figure 230.

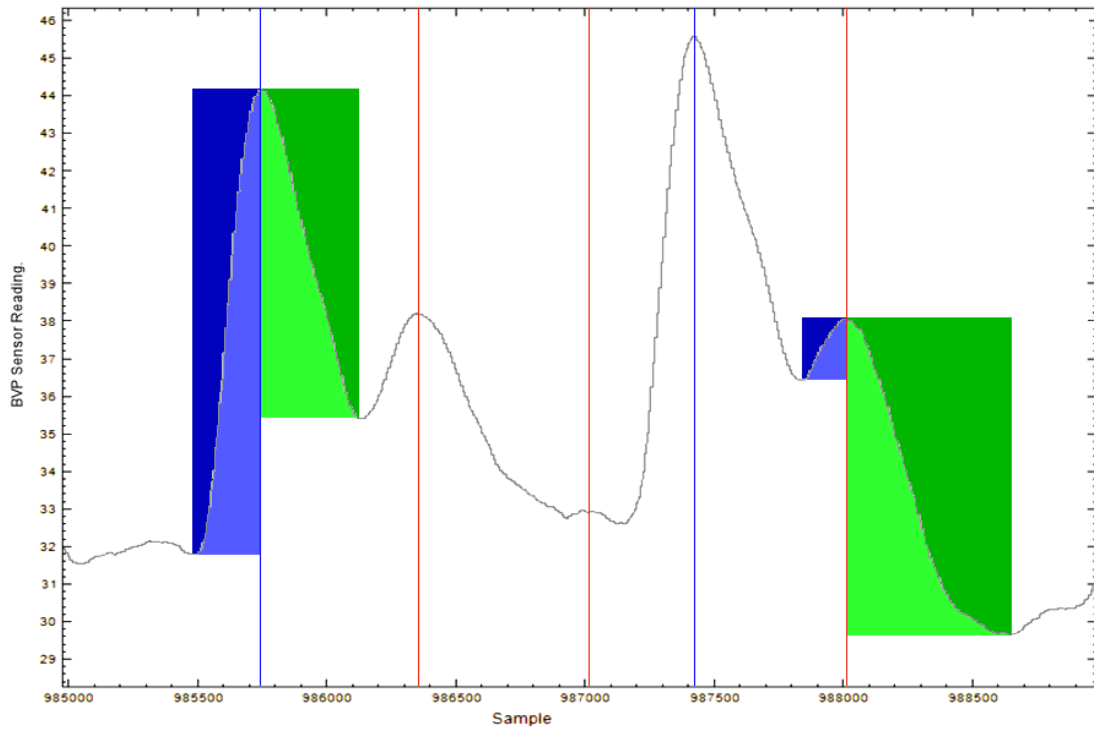

Figure 230: Slope based metrics and the BVP signal

9.6 Galvanic Skin Response

The Galvanic Skin Response was analysed using a subset of the feature extraction techniques employed on the EMG. In this case the window's size was set to 125ms, but otherwise all calculations were identical. Distributions are shown for all our participants in figures Figure 231 through Figure 235.

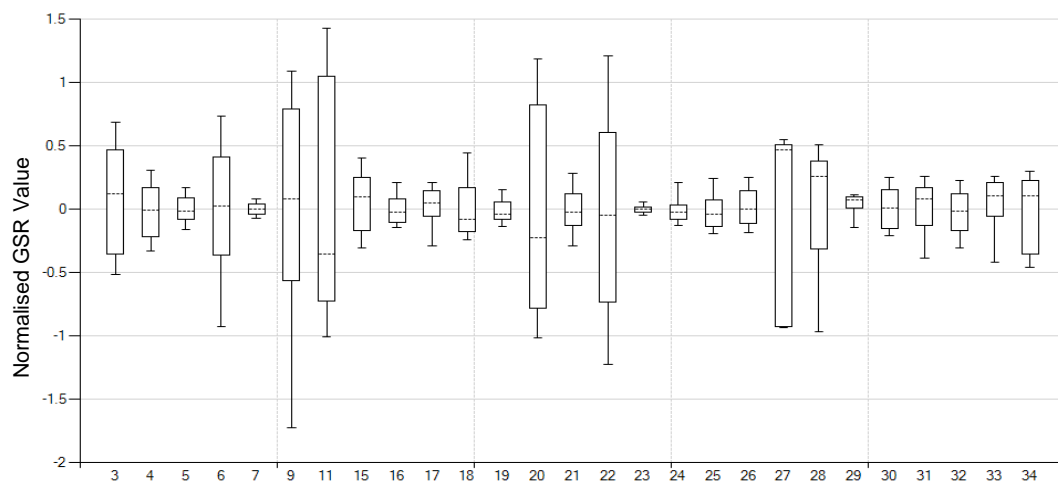

Figure 231: Distribution of the IGSR (see IEMG) calculation for GSR signal

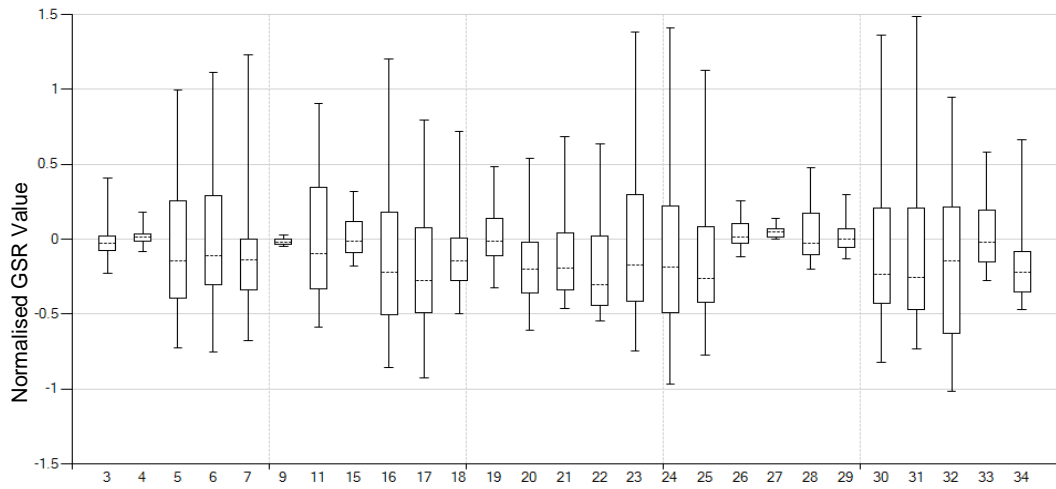

Figure 232: Distribution of the Mean Absolute Value Slope (MAVSLP) calculation for GSR Signal.

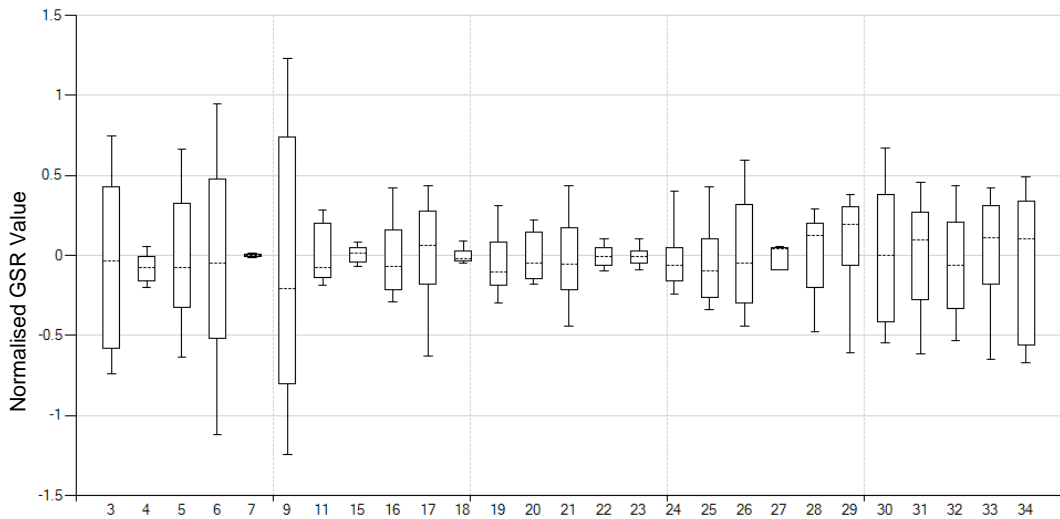

Figure 233: Distribution variance calculation for GSR signal

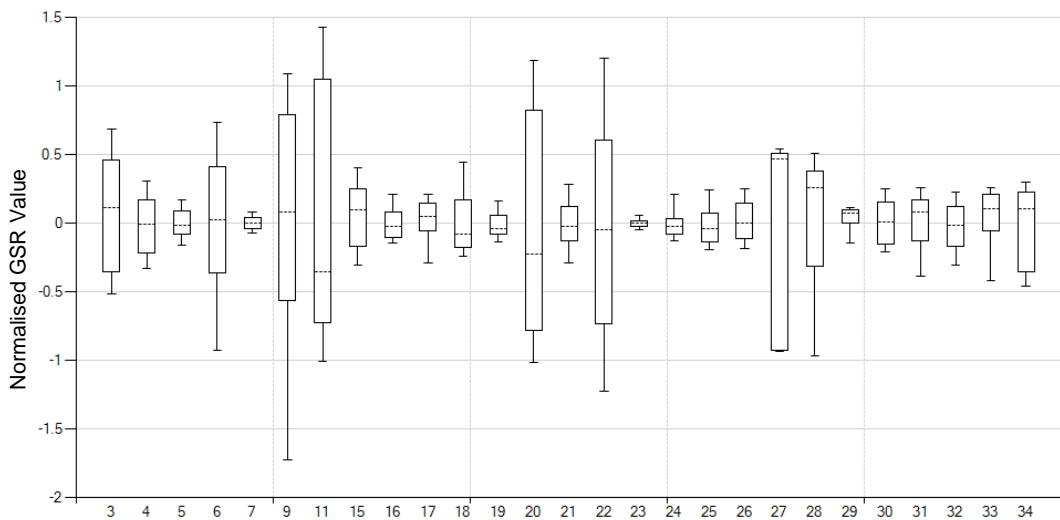

Figure 234: Distribution IRMS calculation for GSR signal

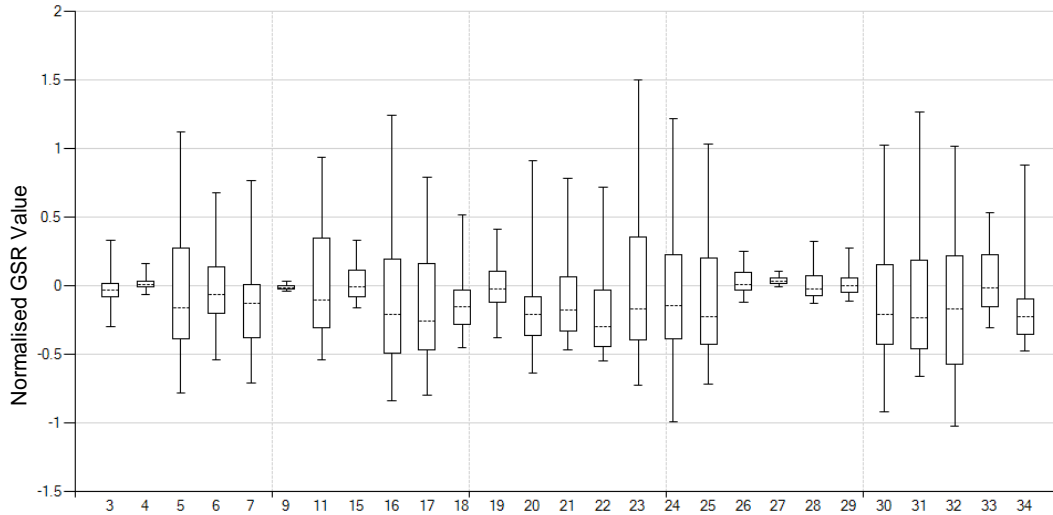

Figure 235: Distribution Wilson Amplitude (WAMP) Calculation for GSR Signal

9.7 Sampling of Time Series Data

To correctly capture the sample, the features extracted from the data is an interesting task. At any given time the body may be functioning at a different rhythm. If samples are taken every second, a quick heart rate (< 1 Hz) may be under sampled and beats missed. Additionally at a one second sample rate, a slow heart rate (> 1 Hz) may have beats sampled twice, leading to misleading data that would show no change in the last second.

Since features are extracted at different frequencies it is logical to sample at a rate greater than the smallest window size used in feature extraction.

Feature Set	Rate of change of extracted features.
ECG	700ms - 1500ms approx
RESP	800 - 2500ms approx
EMG	1000ms
BVP	700ms - 1500ms approx
Temp	1000ms

Our solution was to sample twice a second at 500ms. In this case data will often be double sampled, so the classification algorithm needs to be aware that seeing the same value twice does not (necessarily) indicate a zero rate of change. An example of this sampling is shown in Figure 236. In this figure the EMG and related feature (MAV) are shown as the top lines and a filtered ECG and related feature (QT Interval) are shown as the lower lines.

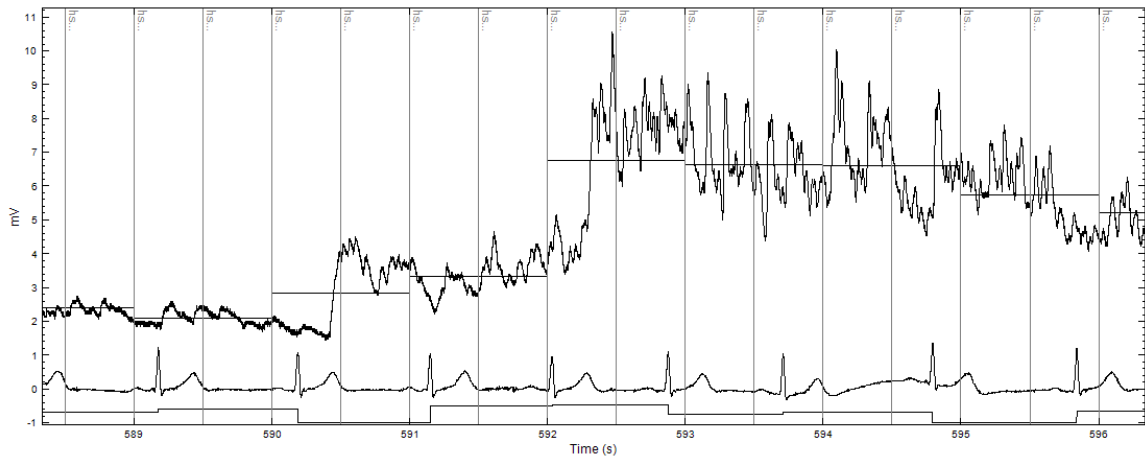

Figure 236: Feature sampling at 500ms

An alternative to interval sampling may be to take a sample once every heart beat, either at a known feature (Figure 237), or randomly (Figure 238). However this sampling method will result in erratic sampling of other features as the heart rate may go from being faster than the window used elsewhere for feature extraction, to slower. This makes rate of change compensations more difficult.

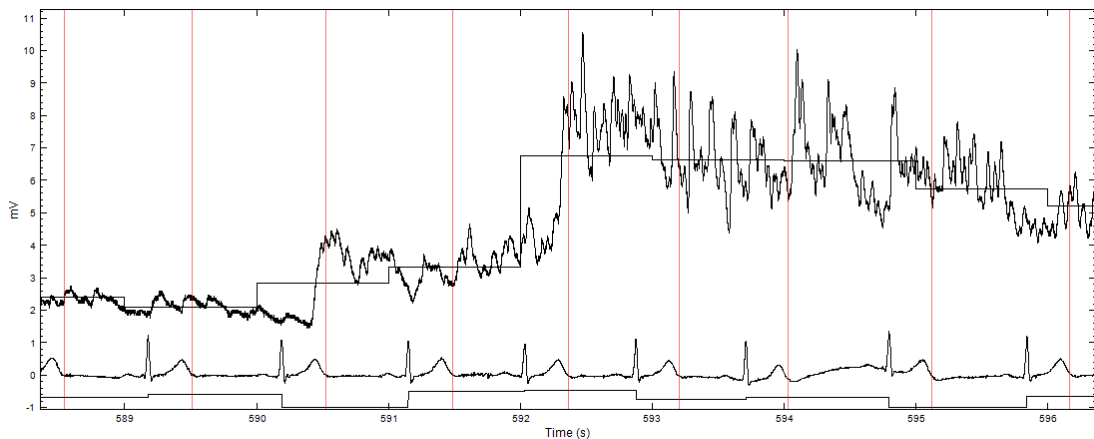

Figure 237: T-wave finish per-heartbeat sample

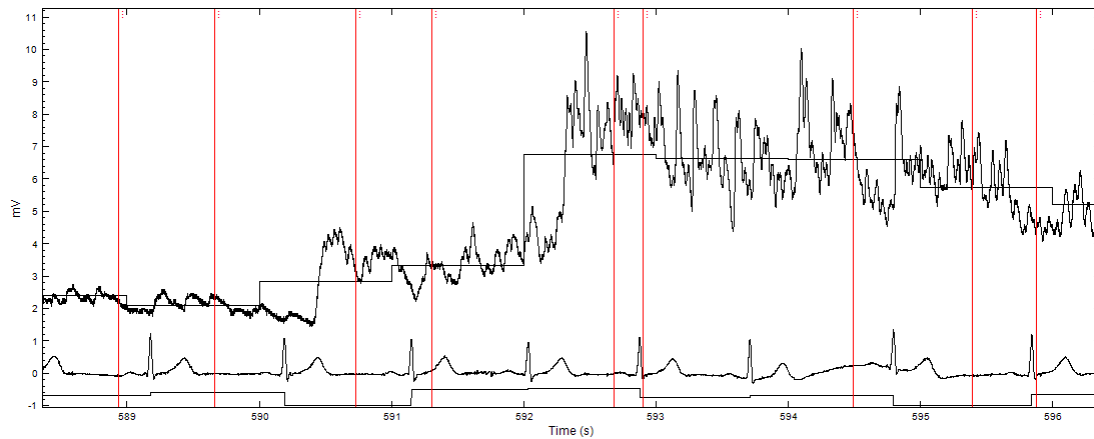

Figure 238: Random per-heartbeat sample

9.8 Summary

In this chapter we discussed the signals we obtained and how they were cleaned so as to remove any noise present in the data. We discussed how we detected when the recording equipment produced an error or artefact and we discussed other issues in some signals such as baseline drift.

We also described how we extracted features from the cleaned up signal data. Particular attention was paid to the ECG and EMG data as these were information rich data sources presented as complex signals with amplitude, spectral and morphological characteristics that were potentially important to our work

The aim of this part of the work was extract repeatable metrics which were sensitive to the nature of the biological process and not influenced by noise or algorithmic limitations. This is a major point of rigor in our investigation.

10.0 Analysis of Collected Data

“The most exciting phrase to hear in science, the one that heralds new discoveries, is not 'Eureka!' (I found it!) but 'That's funny ...' ”

-Isaac Asimov (1920 - 1992)

In our experiment two sets of data were collected, firstly physiological data was recorded and secondly emotional rating data was recorded. Our hypothesis is that classification algorithms can be trained to efficiently predict the emotional ratings given the physiological data as input. To that end we must examine the quality of the emotional and physiological data obtained from the experiment, before proceeding towards classification tasks.

This task is non-trivial as the data exhibits the typical characteristics of data obtained from biological sources:

- High dimensionality;
- Small sample size;
- High degree of dependency;
- Missing values;
- Data is derived from different biological/physiological processes.

A good description of dealing with these problems/challenges was presented by the e-LICO multi-omics prediction challenge (Woznica, Kalousis, Schanstra, & Klein, 2010). As per their description of dealing with data from multiple sources, we are taking the most direct approach advocated, joining all different data sources into a single heterogeneous table.

This chapter starts by examining how we can group the rating results into emotional states. We then introduce our lexicon for naming our features. We follow this up with an investigation into which external influences produced any measurable and predictable effect on our physiological data.

We then examine the IAPS stimuli to determine their effectiveness as an emotional stimulant. This is followed by a review of how our participants responded to our IAPS presentation compared to responses of participants in previous studies.

For purposes of exploring the data, we then display some observed trends using a series of plots and visualisations. The chapter is concluded with an examination of how we sample the data for the purpose of training classifiers, followed by an

investigation to determine a set of significant features which will be used for further classification tasks in the following chapters.

10.1 Labelling of Data for Classification and Analysis

In this section we will calculate labels for our data that represent the participants' emotional state. This is necessary for classification and is applied to every recorded observation. To create these labels we must transform the Self Assessment Manikin (SAM) ratings into a set of discrete labels.

We propose two ways to accomplish this task:

- Divide the data using a grid.
- Use k-Means clustering to group “clusters” of scores into affective states.

The grid scheme divided the Arousal and Valence emotion spaces and discarded the Dominance results. Discarding the Dominance results is a common practice, e.g. (Surakka & Anttonen, 2005), (Feldman, 1995), (Lewis et al., 2007) & (Kulic & Croft, 2007). The Dominance is removed to simplify working with emotions in a lower dimensional space as it has been identified as the least important factor by Osgood, Suci, and Tanenbaum (1957) who identified the Arousal, Valence and Dominance axes. In our work the grid used contained nine squares formed by dividing the data with what is known as a dead-zone.

We introduced “dead-zone cut-offs” which are limits at which an emotional state is considered “neutral. Performance of dead-zone values of 1, 3, and 5 were trialled to determine the best configuration. The resulting grids are shown in Figure 239. These grids are similar to grids used by Russell and Mendelsohn (1989) and Regan, Mandryk and Atkins (2007).

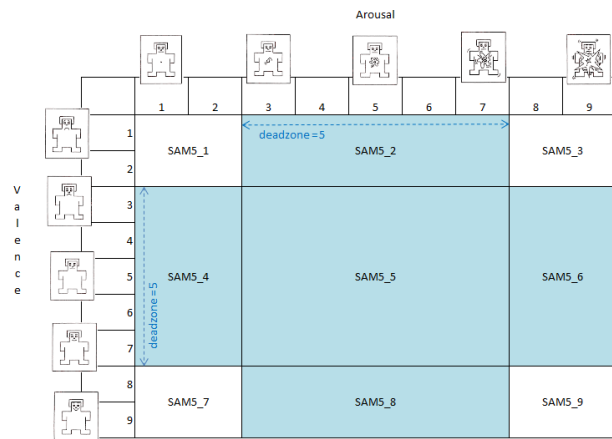
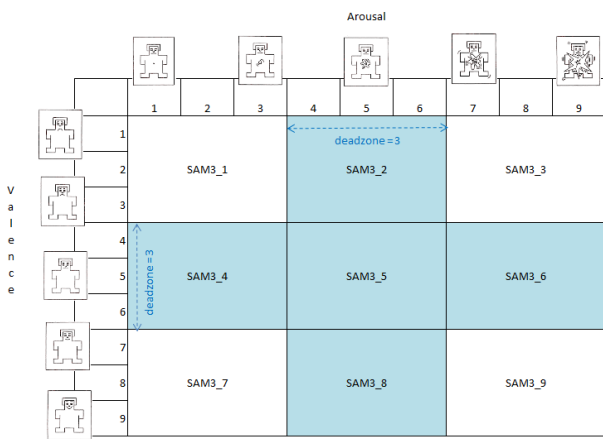
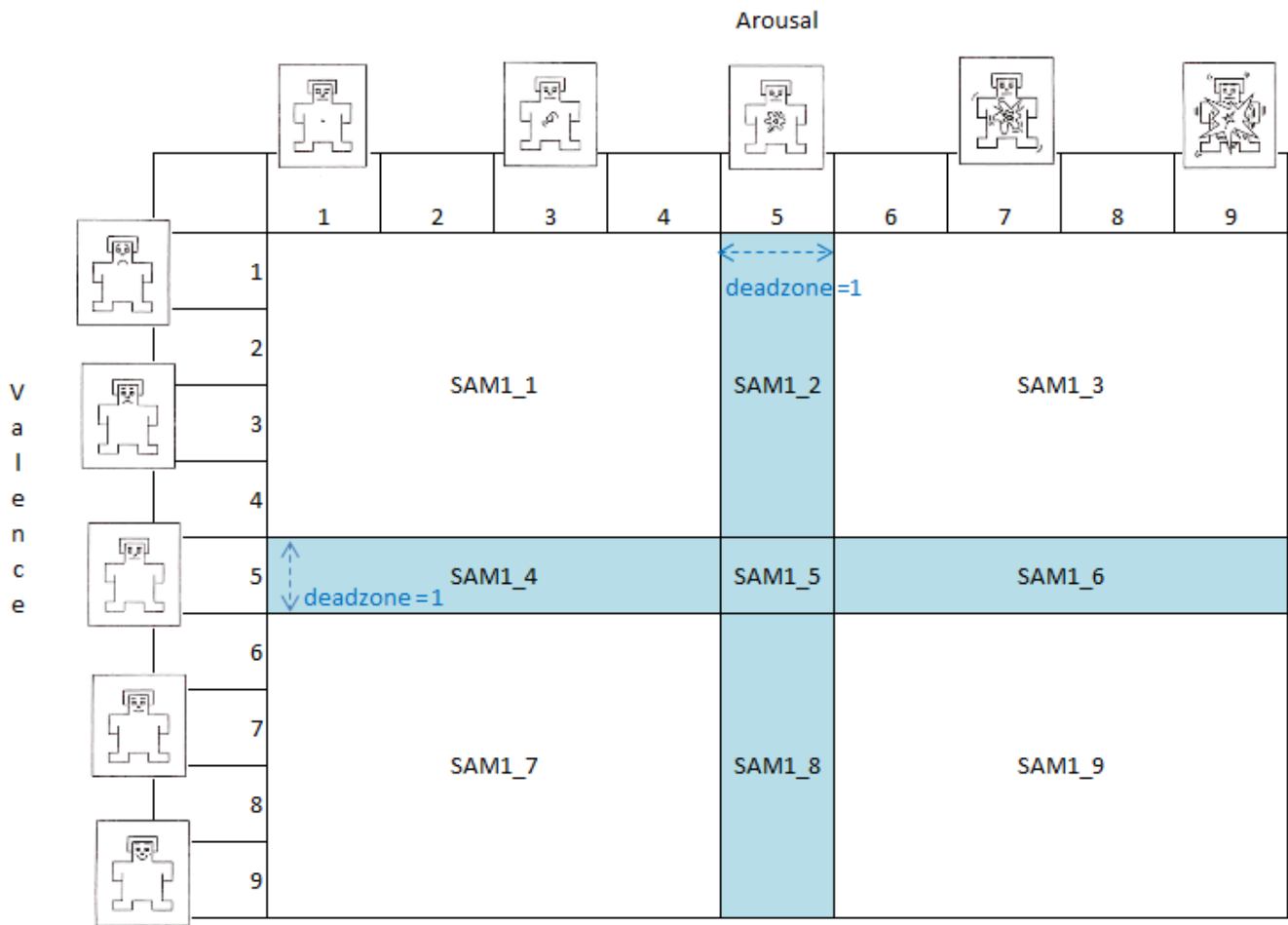

Figure 239: Nine label divisions of emotion space. The division is grid-based and uses a dead-zone of 1 (shown in large at the top), 2 (lower left) and 3 (lower right). The labels used on these figures correspond to labels used elsewhere, i.e. SAM3_5 is the 5th label on a grid with a dead-zone of 3.

10.1.1. Finding a Good Dead-Zone for the Grid Division of Emotional States

A primary concern in our dead-zone selection task is good division of the data into evenly sized bins (also called buckets). This assists the classifier training, in that under-represented states may not be well learnt by some of our classifiers.

To show the resulting bin sizes we plotted a histogram (Figure 240) and pie chart (Figure 241) to show the distribution of the labels for our entire training set by various dead-zone settings. Notably we found:

- Few instances of the 6th SAM (neutral Valence, high activation) label are represented by any of the dead-zone settings;
- A dead-zone of 5 over-represents the 5th SAM label (neutral Valence and activation);
- A dead-zone of 3 provides the best balance, see Figure 241.

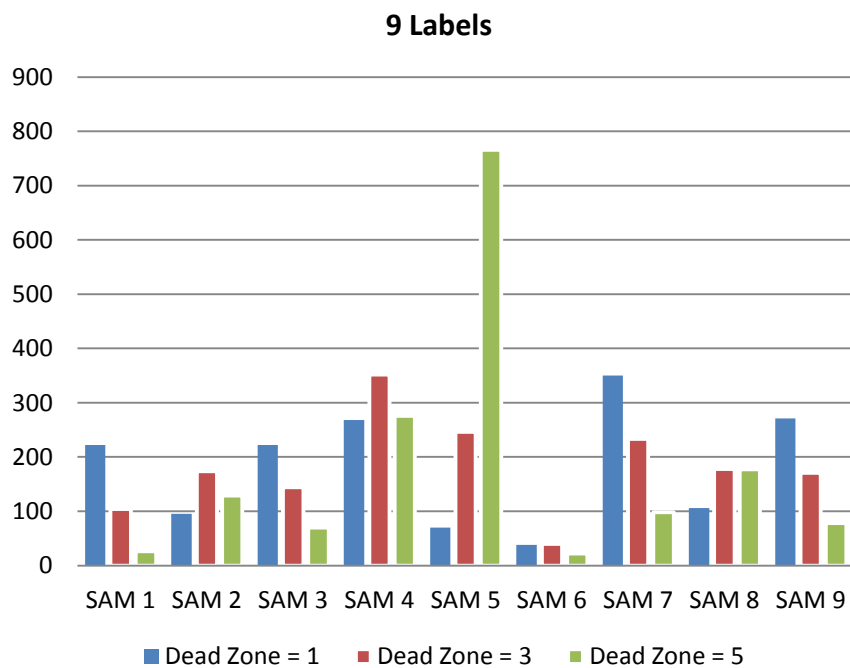

Figure 240: A histogram showing the three bucket distribution archived by dead-zones of 1, 3 and 5.

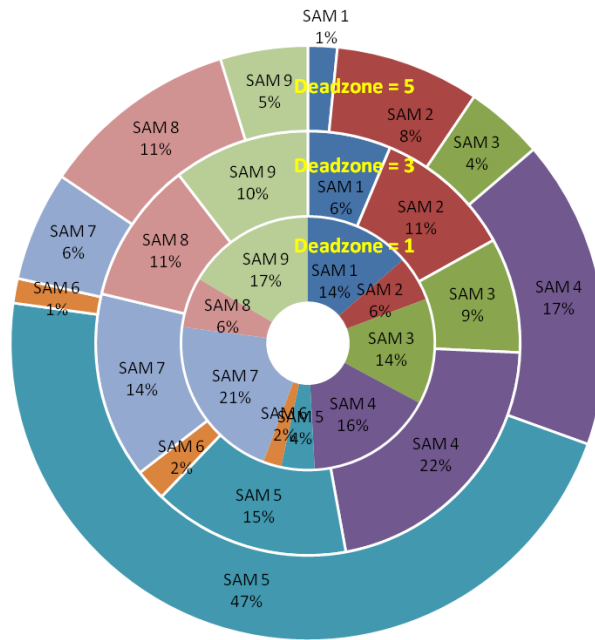

Figure 241: The “data distribution donut” for SAM labels.

10.1.2. Applying k-Means Clustering to the SAM Ratings

In order to have a set of emotion labels that also take into account Dominance ratings, we decided to find “natural groups” of the SAM scores and label all observations by their relevant cluster. This approach was used because we felt that extending the grid scheme into three dimensions would present too complex a classification task with 27 emotional states.

To achieve this grouping of the three (dimensional) SAM scores, we used the k-means clustering algorithm (Hartigan & Wong, 1979) to produce a set of k regions to which a result could belong. In this situation k must be determined experimentally, often using multiple measures as shown by Maulik & Bandyopadhyay (2002).

It was found that eight clusters ($k=8$) created the best grouped data. This was accomplished by finding a balance between the number of clusters (k) and two metrics indicative of the variance of the clusters. The difficulty is that as the number of clusters increases, the variance decreases (until the final case of $k=n$ and $\text{variance}=0$).

To derive the best value for k, we performed grouping for a practical range of k-values; k=2 to k=12. The results were plotted with the number of clusters against the average distance from the cluster's centroid. We also plotted a well-recognised performance metric, the Davies–Bouldin index (Davies & Bouldin, 1979), given by Equation 30. The results are shown in Figure 242. The average distance curve will always be 0 at k=n, and the best trade off between a small value of k and a small average distance will [should] be at the knee of the curve (Maulik & Bandyopadhyay, 2002). The Davies–Bouldin index should also be chosen with k being the lowest value with performance similar to the minimum value obtained. The Davies–Bouldin index is satisfied at k=8, and while there is no apparent knee to the average distance curve k=8 does not appear and unreasonable trade off point, as per Figure 242.

$$DB = \frac{1}{n} \sum_{i=1}^n \max_{j:i \neq j} \left\{ \frac{S_n(Q_i) + S_n(Q_j)}{S(Q_i, Q_j)} \right\}$$

where:

- n = number of clusters
- Q = points in
- $S_n(Q_i)$ = mean distance of all points to their cluster centre
- $S_n(Q_i, Q_j)$ = distance between clusters centres

Equation 30: Davies-Bouldin validity index

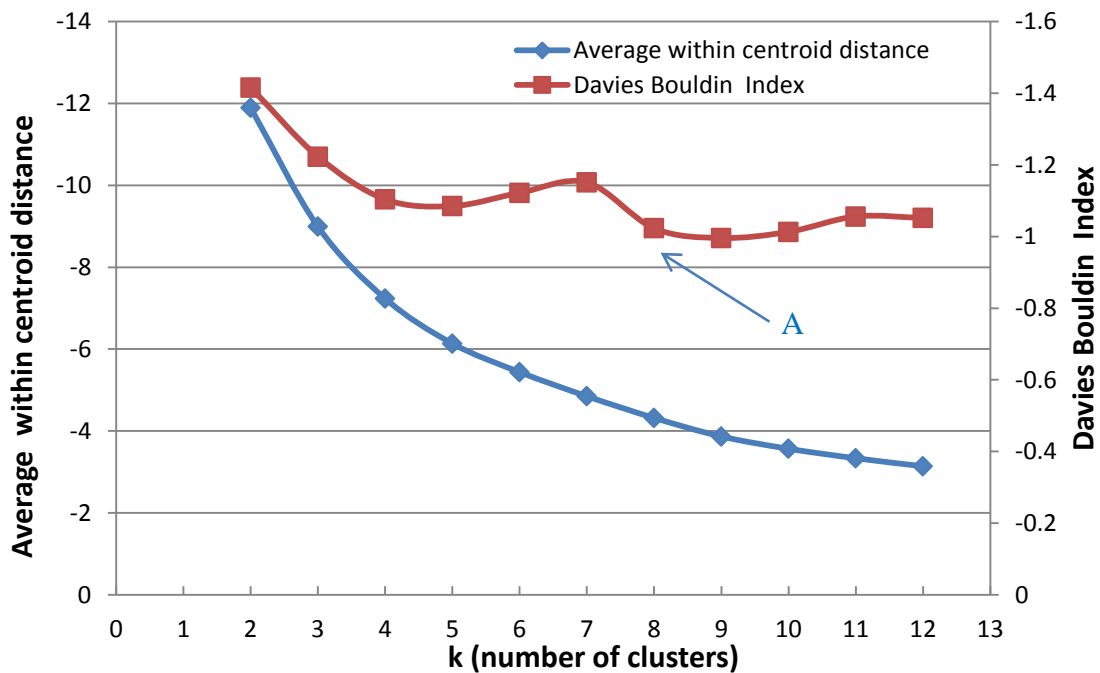

Figure 242: Clustering performance for SAM results; showing (A) The lowest value with performance similar to the minimum for the Davies–Bouldin index.

This produced $k = 8$ centroids as per Table 12 and also improved the distribution over our previous best grids scheme (dead-zone of 3) as per Figure 243.

Table 12: SAM Clustering Centroids

Attribute	Cluster 0	Cluster 1	Cluster 2	Cluster 3	Cluster 4	Cluster 5	Cluster 6	Cluster 7
samScoreA	4.54	7.08	3.69	1.72	2.00	4.97	6.80	6.68
samScoreV	5.66	2.37	2.74	6.97	6.41	2.70	7.88	8.25
samScoreD	5.11	2.46	3.57	2.85	7.87	7.22	2.69	6.59

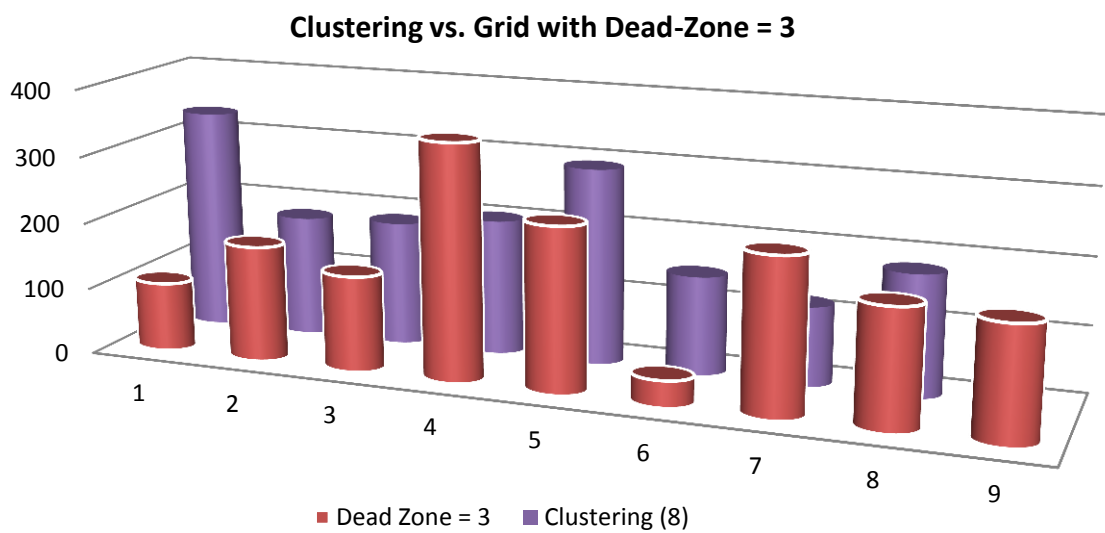

Figure 243: Distribution of clustering labels vs. grid scheme with a dead-zone of 3.

Representing our clustering visually, in Figure 244, we see that cluster 0, the central polytope, is obviously representative of the neutral emotion. Clusters 3, 4 and 6, 7 (see Table 12) represent similar Valence/Arousal states; but differed significantly in Dominance.

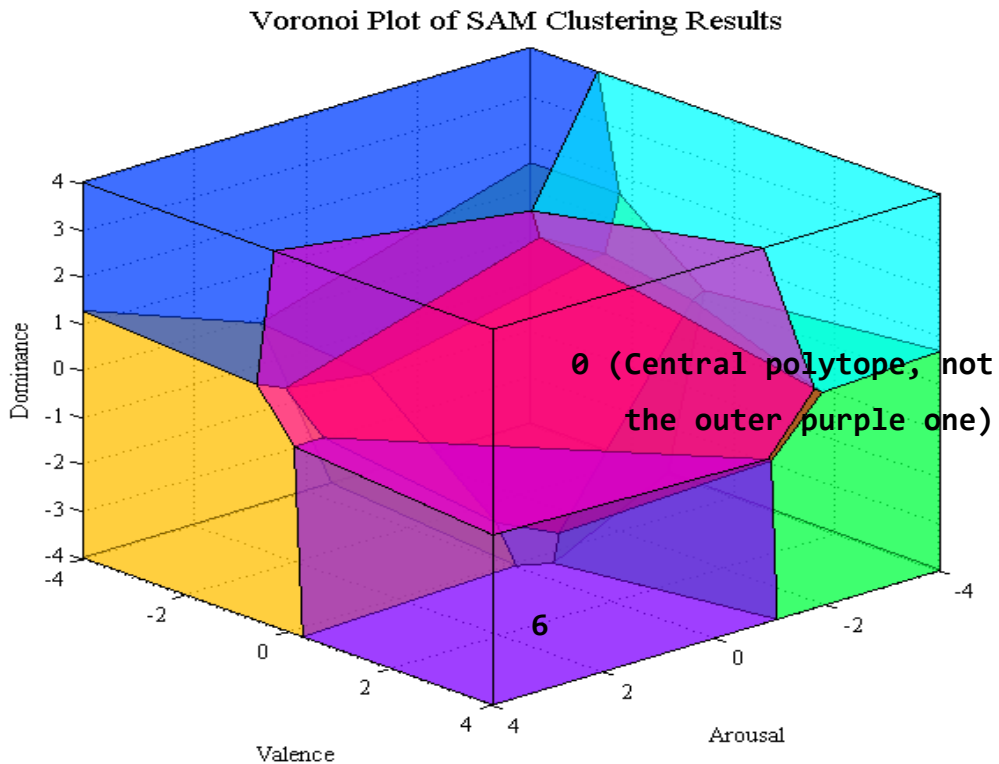
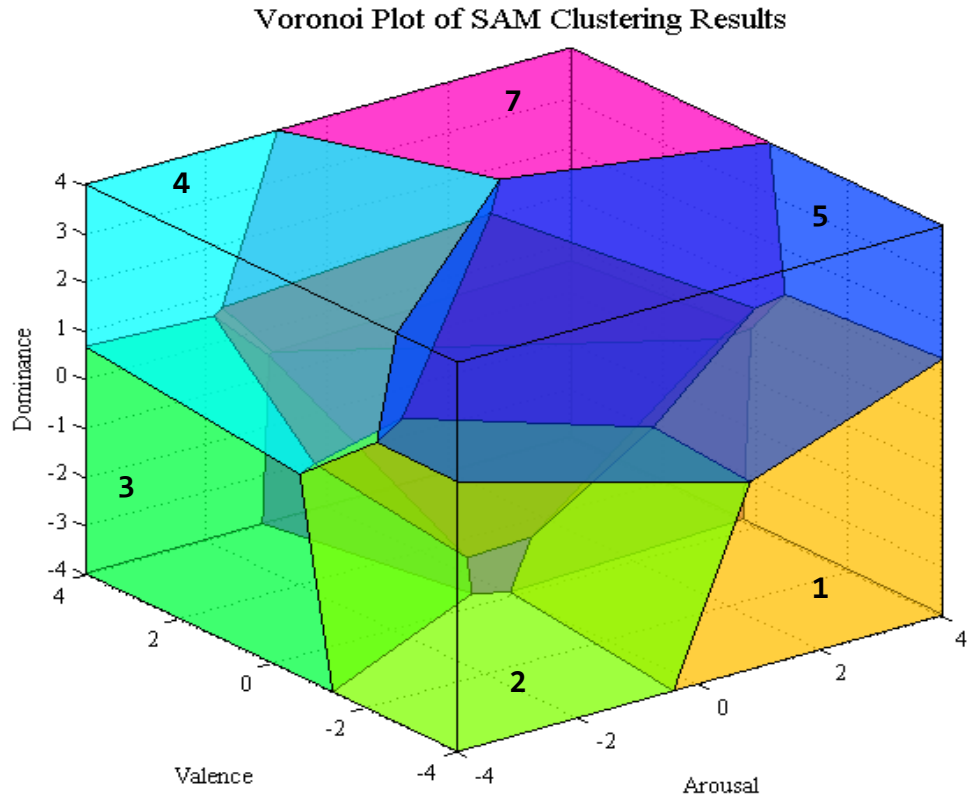

Figure 244: Two Voronoi plots of the results of our work to cluster the SAM responses. The plots are shown from two rotations and the three rating axes have been adjusted from the range [1 to 9] to the range [-4 to 4] so that 0 is neutral.

10.2 Names Used for Describing Features

With over 5,000 features being investigated in this work, it is not possible to simply list each feature and the formula used to derive it. So we will use a naming system that is self describing.

All feature names are listed in uppercase with underscores used to enhance readability, eg "GSR_FEATURE_SSI". The names used in the written thesis are identical to the names used in the data sets to assist any future investigation by interested parties.

All feature names start with a description of the source of the feature. Most are 64bit floating point numbers that derive from one of the physiological recording sensors and use the prefixes shown in Table 13. There are some additional features and data items listed in Table 14, as well as class labels used for classification listed in Table 15.

Table 13: Feature name prefixes

Name Prefix	Meaning
EKG	electro cardiogram [ECG = EKG]
EMG	electromyography
TEMP	temperature
BVP	blood volume pulse
RESP	respiration
GSR	galvanic skin response

Table 14: Special features

Name	Type	Description
RELATIVE_HEART_RATE	Floating Point	A heart rate (as a frequency) where 1.0 is defined as the person's average beat frequency
DURATION_OF_STIMULUS	Floating Point	How long the person has been exposed to the stimulus (in seconds).
IN_STIMULUS	1 or 0	1 if participant is exposed to stimulus, may include crash screens and rating screens; otherwise 0
IN_INSTRUCTION	1 or 0	1 if in an instructional screen prior to experiment
IN_QUESTION	1 or 0	1 if participant rating the previous input, may include crash screens and rating screens; otherwise 0
IN_EXPERIMENT	1 or 0	1 if the experiment is active, may include crash screens and rating screens; otherwise 0
IN_CRASH_SCREEN	1 or 0	1 if in the crash screen scenario; otherwise 0
IN_CRASH_RATING_SCREEN	1 or 0	1 if in the crash screen scenario (rating task); otherwise 0
IN_IAPSRATING_SCREEN	1 or 0	1 if rating a stimulus slide; otherwise 0
IN_IAPSSLIDE	1 or 0	1 if viewing a stimulus slide; otherwise 0
FEED_BACK_LONGEST_KEY_DELAY	1 or 0	(real) a metric concerning how fast the user is working
FEED_BACK_NUM_BUTTONS_PRESSED	1 or 0	(not used)
FEED_BACK_TIME_TO_RATE	1 or 0	(real) a metric concerning how fast the user is working

Table 15: Classification labels

Name	Type	Description
SAM_SCORE_(A/V/D)	1 to 9	The rating in the SAM answer sheet
samClassDZ(x)Div9	SAM9_1 ... SAM9_9	One label for each square on the grid divided by the dead-zone(x) as per Figure 239
samClassDZ(x)Div(A/V/D)	SAM(A/V/D)_0... SAM(A/V/D)_2	For Arousal, Valence and Dominance, was the value below, in or above the dead-zone (x)
samClassCluster8	SAMCLUST_0... SAMCLUST_7	One label for each of the clustering results

10.3 External Factors in Recorded Physiological Data

There exists sufficient research to suggest that the human emotional and physiological state may be altered by many things beyond our control. We have documented how the experiment methodology has screened out as many external influences as possible, but there remain several that could not be practically eliminated from the experiment. Where this is the case, it was attempted to make record of the state of the influence so data may be compensated and adjusted where possible.

Biases suspected to be present in emotional data include:

- Participant mood prior to the experiment;
- Diurnal autonomic variations;
- Menstrual (cycle) autonomic variations;
- Environmental variations;
- Cultural background;
- Gender.

Biases known to be present in physiological data include:

- Height;
- Weight;
- Age;
- Gender.

As one of the main goals of the preparation phase of the experiment was to get the participants into a neutral emotional state, two of these factors were considered too invasive to obtain prior to experimentation.

- Menstrual (cycle) autonomic variations;
- Cultural background.

Even though these biases may have effects on the data, a decision was made for reasons of participant comfort and ethical clarity to leave these as unknowns.

10.3.1. **Participant Mood Prior to the Experiment**

Participant mood was ascertained in general conversation with the subject upon them being prepped for the experiment. The nurse doing the sensor placements would ask questions like "how was your day?" and "what did you do this morning?". The tone was conversational and the participant was unaware that a synopsis of the answers was being recorded.

10.3.2. **Diurnal Autonomic Variations**

Variations in mood according to diurnal (time of day) rhythms have been recorded in mentally ill patients in various studies (Bouhuys, Jansen, & van den Hoofdakker, 1991). These variations are related to mammalian autonomic systems being linked to a diurnal rhythm. This rhythm is likely to affect human emotion and physiology.

Recent work done by Pasca et al., (2005) suggests that the time of day impacts mean Skin Conductance Levels (SCL) and results in an alteration to Galvanic Skin Response (SCR in the diagrams, GSR in this text) recordings taken for pleasant and unpleasant visual stimulus. The results of this portion of the study are shown in Figure 245 and Figure 246. Of particular note was that an unpleasant picture seen at 9:30 am

will have a similar GSR to a neutral picture seen at 1:30pm. It was also noted that the effects of this variation seem to peak at 1:30pm.

From the same study it was found that SAM responses to visual stimuli also showed an alteration in "emotional experience" (a term used to describe the z-transform of the individual SAM data). The results from this portion of the study are shown in Figure 247. A sudden peak at 3:30pm followed by gradual decline is also observed in these results.

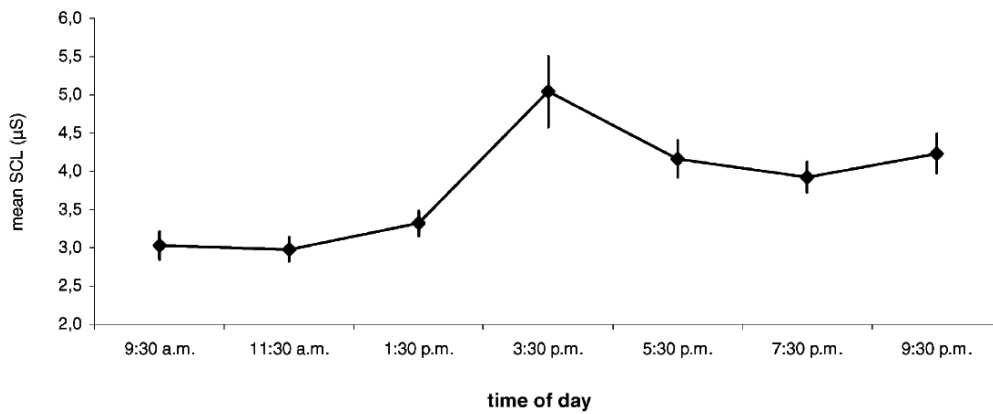

Figure 245: Diurnal variations of mean skin conductance level (Pasca et al., 2005)

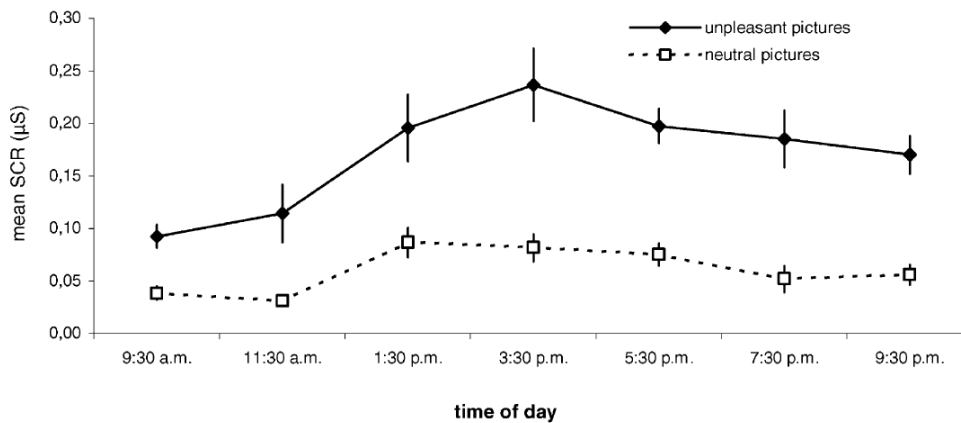

Figure 246: Mean amplitude of skin conductance (Pasca et al., 2005)

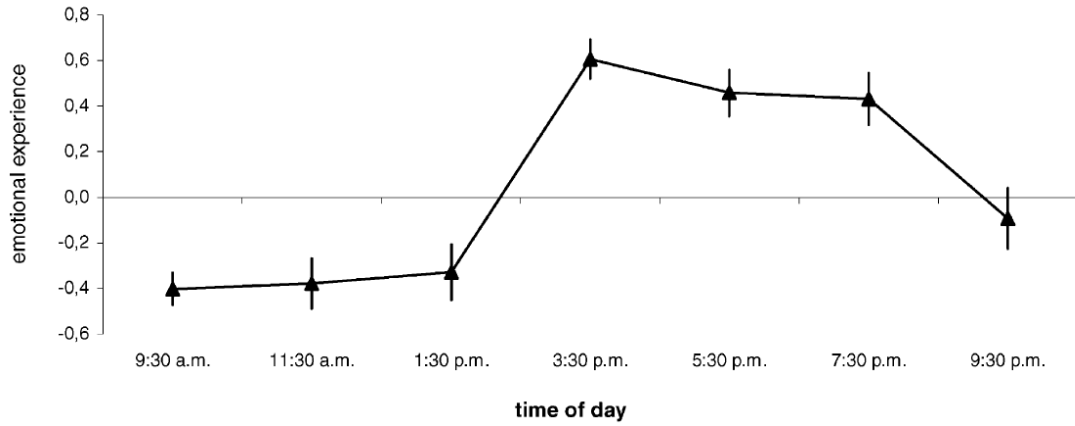

Figure 247: Mean values of emotional experience (Pasca et al., 2005)

Day	Date	9	10	11	12	13	14	15	16	17	18
Day 1	5/08/2004		1	2	3	4	5 6 6				
Day 2	11/08/2004		1 1	2	3	4	5 6 7				
Day 3	12/08/2004			1	2	3	4				
Day 4	2/09/2004				1 2		3 3 4	5	6		
Day 5	8/12/2004		1	2 3	4	5	6	7 8	9		10

Figure 248: Experiment timetable

The hour of the day was taken as a coarse indication of the time of the experiments and the data assigned corresponding values. The distribution was a bell curve (as per Figure 248), reflecting the fact that availability of participants was better towards the middle of the day.

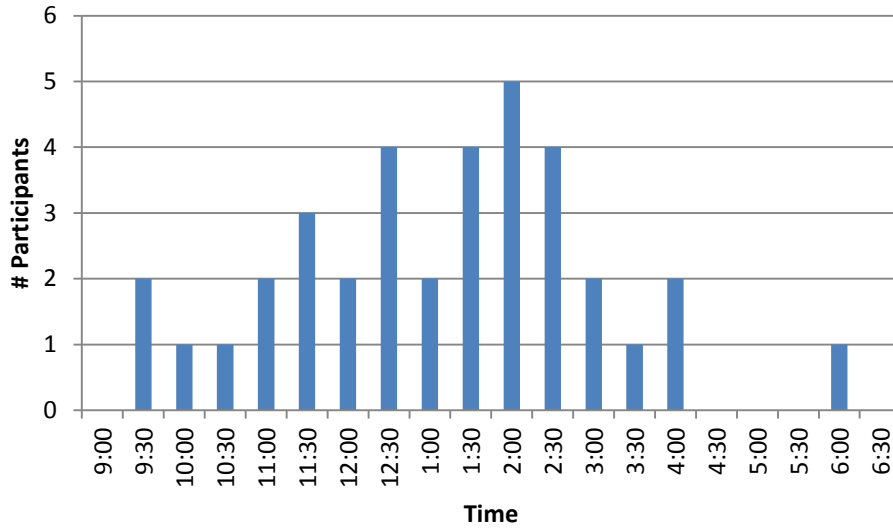

Figure 249: Distribution of time of day when the experiment was conducted.

We found that, in our case, GSR signals increased during the 11am – 3pm period. This result should be qualified by the fact that we also had most of our participants in this time and thus also collected more data for this period. Our GSR levels (normalised by person) over hourly time periods are shown in Figure 250.

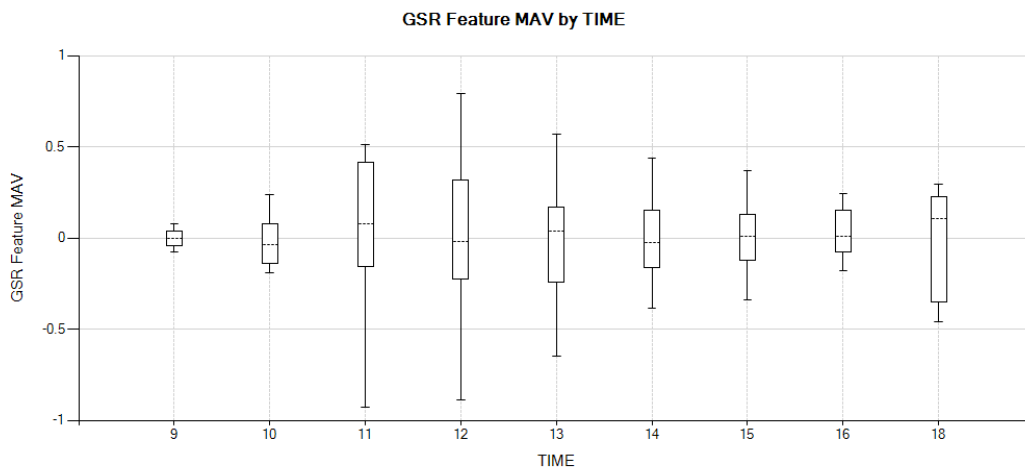

Figure 250: GSR levels (normalised by person) over hourly time periods. Graph used 24hr time.

10.4 Effectiveness of the IAPS Stimuli

Our SAM score results must be investigated to see if they appear valid. This involves a) checking that the slides were effective in eliciting emotions, and b) Discovering if any participants were dishonest or erratic with their emotional self reports. In this section we investigate the validity of the slides as a stimulus and in the next section we examine the validity of the individual participants.

The Valence ratings obtained for the different slides, shown in Figure 251, strongly followed a trend of agreement between participants. That is out of the 38 slides shown, only 5 exhibited a state where someone found something to be pleasant when others considered it unpleasant (or vice versa). These images which were polarised in their appraisals included (IAPS reference number also given):

- A picture of a snake (#1050);
- A barking dog(#1300);
- A large spider (#1200);
- A towel (#7002, a neutral stimulus);
- Scenic shot of a cemetery (#9000).

As it is conceivable that these stimuli may have positive or negative connotations for many people, we see no issues with the results in terms of obviously incorrect ratings.

With only nine exceptions, the Arousal reports for the various slides had a standard deviation of two or lower, which in previous studies, (Bucks et al., 2005), (Lasaitis, Ribeiro, & Bueno, 2008) (P. Lang et al., 2001) would be considered an effective stimulus. Nine slides showed a higher standard deviation. These pictures were:

- A boy with a bison (#2730);
- Action shot of a skydiving formation (#5621);
- Action shot of windsurfing in heavy surf (#5623);
- Scenic shot of flowers and a lake (#5760);
- Scenic shot of a lake (#5780);
- Scenic shot of fireworks over a city (#5910);
- An empty coffee cup (#7009);
- Action shot of people in a roller coaster (#8490);
- Scenic shot of a cemetery (#9000).

Many of the pictures involved were either action shots, or scenic shots, which one would expect are subject to personal taste. Most of these slides are good, but not “excellent” in terms of uniformity of Arousal generated in our study. Slides 2730 and 8490 however could be classified as negative and positive stimuli that are highly subject to personal tastes.

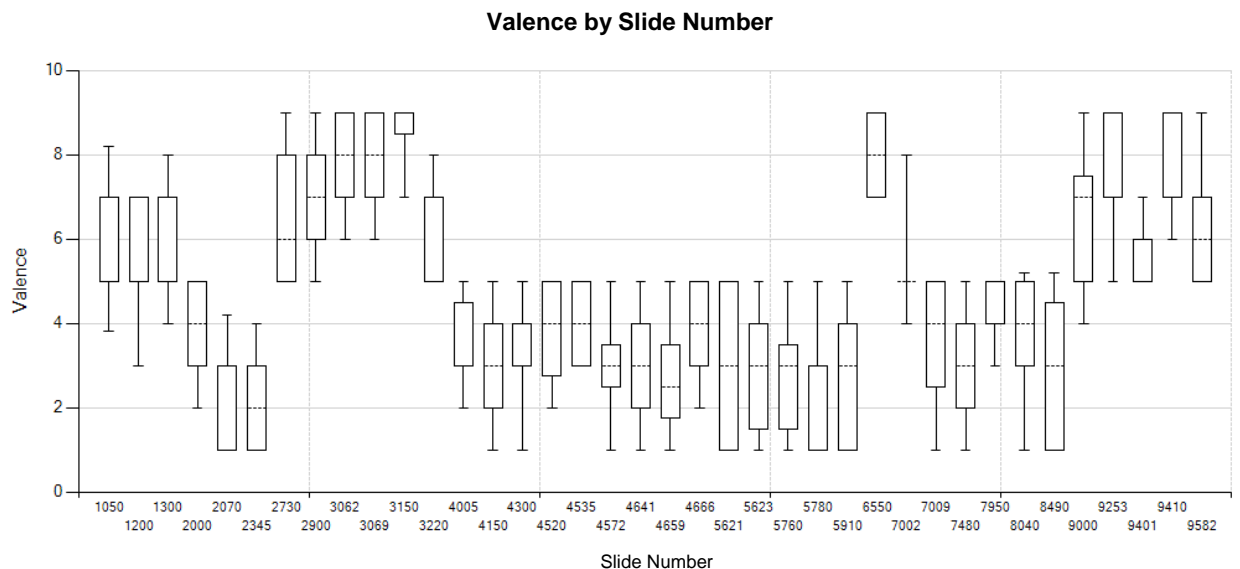

Figure 251: Valence ratings by slide. The slide number is the relevant IAPS ID. A Valence rating of 5 is Neutral. Above that is “bad or negative”, below that is “good or positive”. The slides are not in the same order they were presented to participants.

We generally found that Arousal and Dominance scores (Figure 252 & Figure 253 respectively) varied greatly by participant. This variance is also present in many reference studies (Lang et al., 2001) but in some cases we found significant difference to previous results.

The instances where our results varied in mean Valence scores from reference studies would be best explained by cultural difference between Australian (location of our experiments) and American (location of reference studies). Since the Valence portion of the study yielded excellent results, we assumed that experimental error was not to blame. Further evidence supporting the difference between Australians and Americans in terms of Arousal and Dominance only has come to light in a very recent Australian PhD thesis (Massavelli, 2010). The experiments in that study found older

Australian participants showed prominent differences in Arousal and Dominance ratings for IAPS slides. Massavelli stated:

“Older adults rated pleasant arousing pictures as less arousing and low arousing pleasant pictures as more arousing than did younger and middle-aged adults. Older compared to younger adults reported a higher perceived Dominance in relation to arousing unpleasant pictures.” (Massavelli, 2010)

Given our group was also Australian and we had a broader age range than many previous (American) studies e.g. (Lang et al., 2001) who used primarily first year college students; it would seem plausible that our results should show wider variance than the comparison studies.

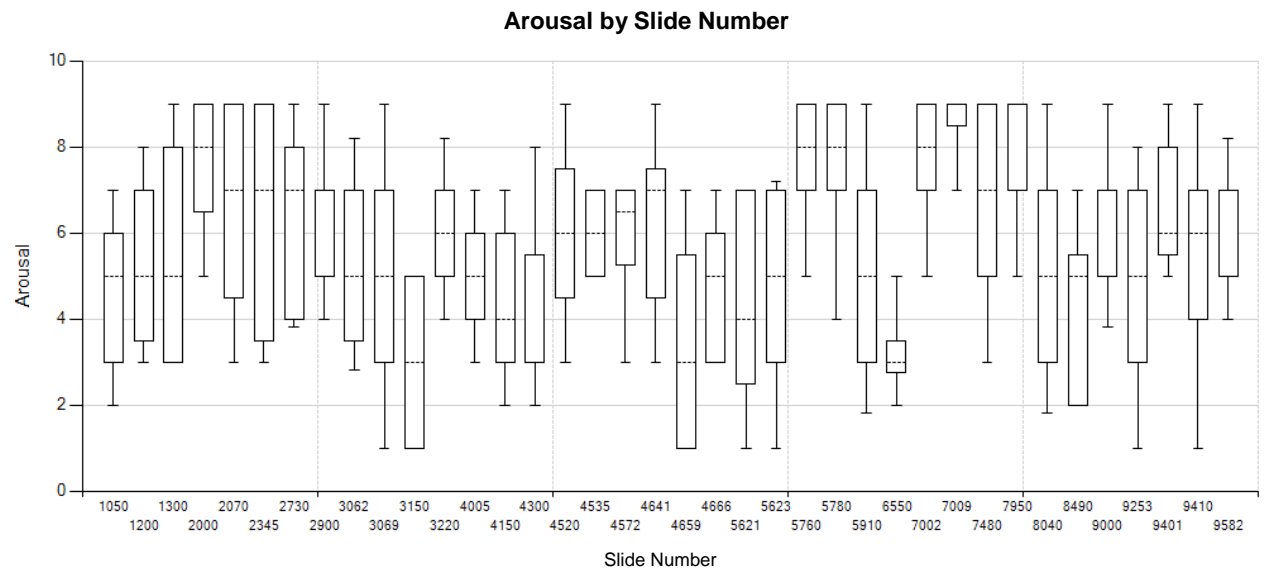

Figure 252: Arousal ratings by slide. The slide number is the relevant IAPS id. An Arousal rating of 5 is Neutral. Above that is “restful state”, below that is “exciting state”. The slides are not in the same order they were presented to participants..

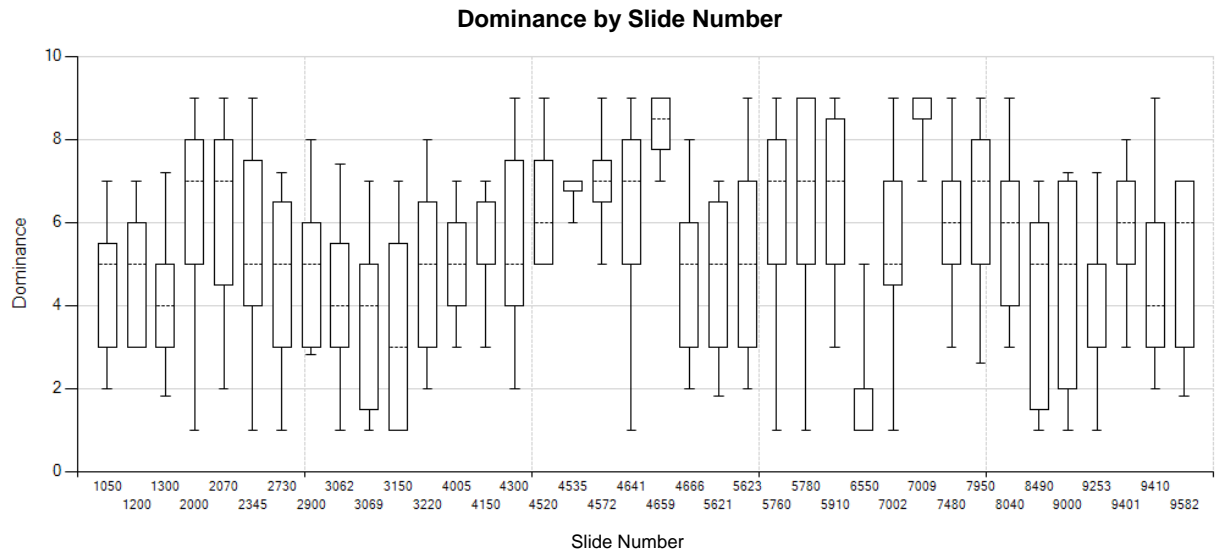

Figure 253: Dominance ratings by slide. The slide number is the relevant IAPS ID. A Dominance rating of 5 is Neutral. Above that is “in control”, below that is “awe/ not in control”. The slides are not in the same order they were presented to participants.

In an effort to more thoroughly compare our slide results to the American reference studies, a set of scatter plots were created comparing Arousal and Valence results. In general the reference studies also showed the same large Arousal variances we had, and the results were centred on the same mean. A typical case is shown in Figure 254, and a full set is available in the appendix (see section 14.3).

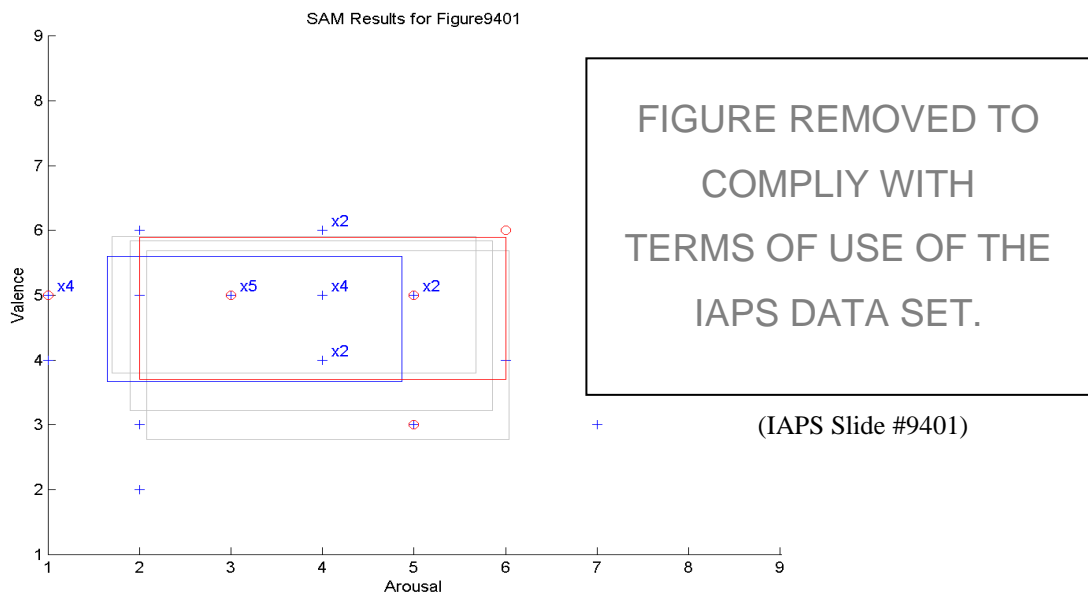

Figure 254: Comparison of our SAM ratings and those of reference studies. Responses that were chosen by more than one participant are labelled x2, x3 and so on. Male responses are in blue, female in red. A rectangle of matching colour is drawn to represent the area around the mean bounded by one standard deviation. The areas of one standard deviation about the mean from previous studies (P. Lang et al., 2001) are shown in grey.

10.4.1. Example of Cultural Bias in Australian Respondents: Snake Fear is Less Prevalent

One of the atypical results we found is shown in Figure 255. In this case the Arousal levels for both male and female participants were significantly lower than in the reference studies. This is an interesting case because the subject involved is a snake. Snakes have often been studied in regards to human fear e.g. (Rimm & Briddell, 1981) (Dimberg, 1998), and often cited as a natural instinctual fear (Ohman, 2009); though there are many counter arguments that snake fear is socially learnt. An example of snake fear being a learnt trait was presented by Mineka, Davidson, Cook and Keir (1984) who stated:

"Rhesus monkeys are born without snake fear. Enduring fear develops after a few observations of another rhesus monkey taking fright at a snake . . . Likewise, a fawn is not born with fear of a wolf, but lifelong panic is conditioned by seeing its mother flee just once from a wolf."

In the case that snake fear is a socially learnt construct, it is possible that there is a culturally specific response in play for this image.

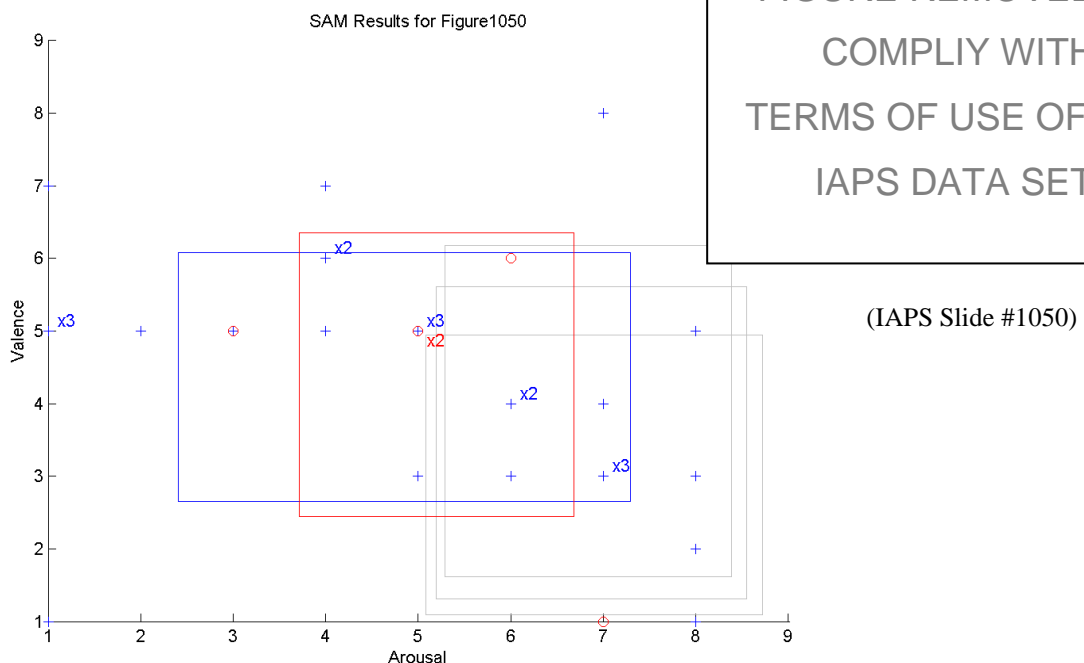

Figure 255: Comparison of our SAM ratings and those of reference studies. Responses that were chosen by more than one participant are labelled x2, x3 and so on. Male responses are in blue, female in red. A rectangle of matching colour is drawn to represent the area around the mean bounded by one standard deviation. The areas of one standard deviation about the mean from previous studies (P. Lang et al., 2001) are shown in grey.

10.4.2. **Example of Cultural Bias in Australian Respondents: A Boy with his Head in a Bison's Arse is Just Not Interesting**

There was one slide in our study that had an extreme lack of correlation with existing ratings from the American based IAPS studies. We will examine this slide in this section with an argument for cultural bias.

This slide (IAPS #2070, see Figure 256) is a classical emotional stimulus where people will have varied responses. In this case a person may:

- Feel empathy for the boy;
- Feel disgust at an apparently vulgar action;
- Laugh at the comical situation;
- Be offended by the naked person;
- Be confused about what they are seeing;
- Be uninterested in the topic.

It is clear that the benchmark American studies, (Lang et al., 1997), show most participant responses had an unpleasant Valence and high Arousal. That is the participants by and large were responding in one of the following response categories:

- Feeling empathy for the boy;
- Feeling disgust at an apparently vulgar action.

However in this study most responses were low Arousal (see Figure 257) indicating that perhaps our participants were confused or unengaged by the image. The heavy difference between our results and the results obtained in the three studies by Lang et al., (1997) is shown in Figure 256.

The plot shown in Figure 256 is a stacked scatter graph of the results in this study as compared to the results of the benchmark studies by Lang et al., (Lang et al., 1997). The rectangles show a results distribution, they are centred on a mean and extend one standard deviation either way from the mean. The grey rectangles show previous studies, the blue and red ones show males and females (respectively) from this study. The blue "+" is used to indicate a male response in this study and the red "o" indicates

a female response. A label in the format x2, x3, x4... is used to signify multiple results being of the same value.

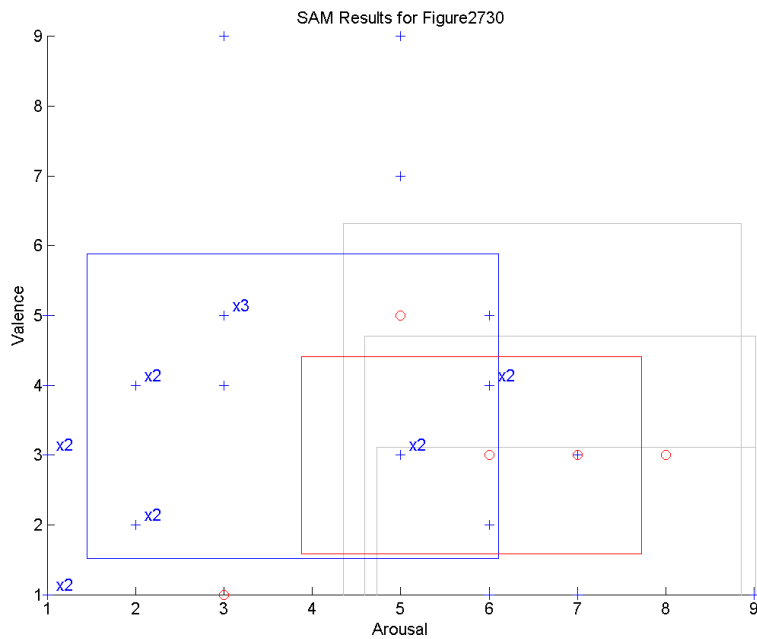

FIGURE REMOVED TO COMPLY WITH TERMS OF USE OF THE IAPS DATA SET.

(IAPS Slide #2730)

Figure 256: Scatter plot of SAM results for slide 2730. Responses that were chosen by more than one participant are labelled x2, x3 and so on. Male responses are in blue, female in red. A rectangle of matching colour is drawn to represent the area around the mean bounded by one standard deviation. The areas of one standard deviation about the mean from previous studies (P. Lang et al., 2001) are shown in grey.

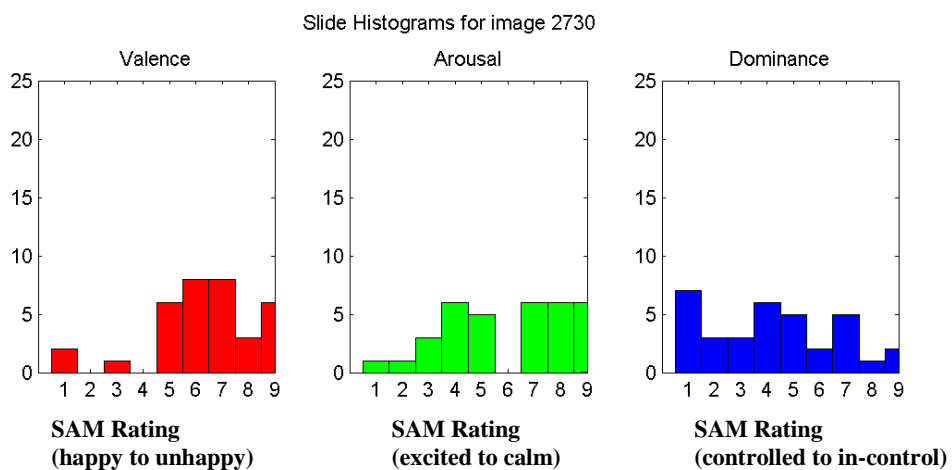

Figure 257: Result histograms for slide 2730. In the arousal graph lower numbers indicate excitement and higher numbers indicate calmness.

It is not entirely clear why the participants of this study, and perhaps Australians as a whole, are unconcerned with this image. A viable explanation would seem to lie in a possible general desensitisation to the misfortunes of cattle. At the time of the experiments, much of Australia's cattle country was three years into drought and it was not uncommon for news programs to feature images of starving, dehydrated and dead cattle.

10.5 Participant Self Assessment Responses

To assess the reliability of individual participants' SAM results, each participant was compared against known mean results. To do this a set of histograms was created to show how often a participant responded within a certain number of standard deviations from the study's mean evaluation for each slide. These histograms are available in appendix 14.2 and an example is given in Figure 258.

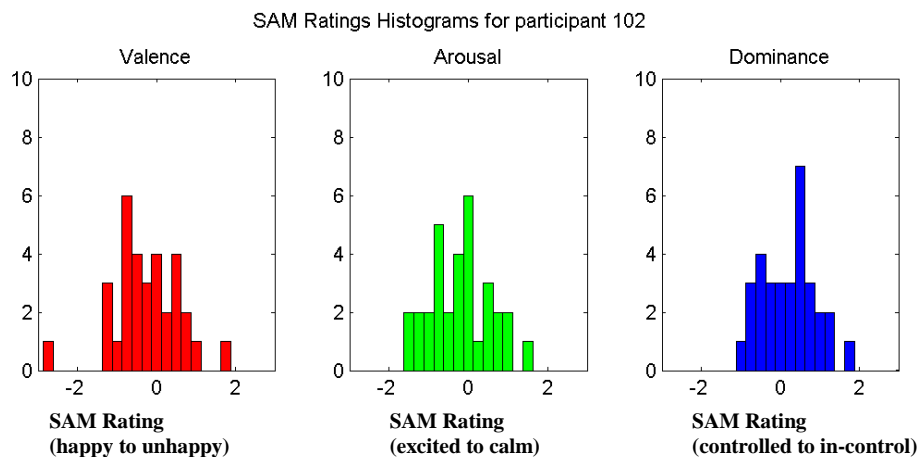

Figure 258: Example result histogram (for Participant 2, on day 1).

If our participants responded to the stimulus in a similar way to the reference studies, then the histograms should look similar to normal distributions, with the peak at zero and most data within two standard deviations of zero. The majority of data collected follows this trend. However some results do not, which may indicate that the participant:

- Does not have “statistically normal” emotional responses (which is not at all unusual);

- Has a cultural bias which causes him/her to react differently to the reference studies (which were conducted in a different country);
- The participant was not completing the survey properly.

We divided the histograms into nine categories as shown in Table 3.

Table 3: SAM results problems

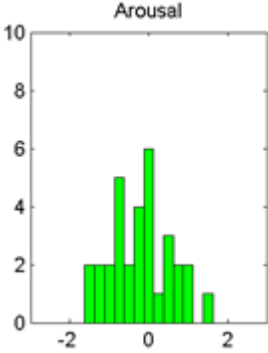
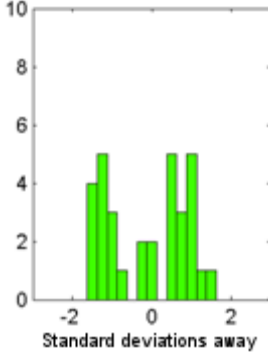
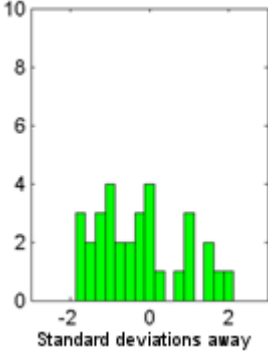
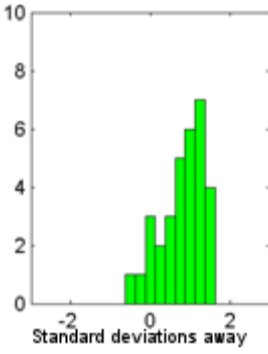
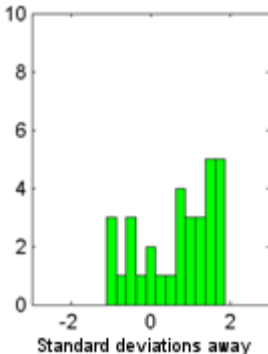
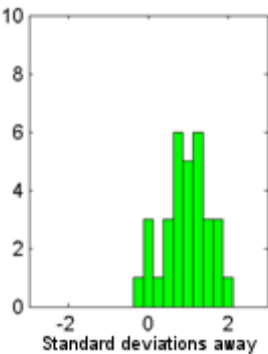
Type	Example	Type	Example
1&2) Good or OK (when the mean = 0 and <i>most</i> values lie in the range -2 to 2)		5) Inverted (values lie in the range -2 to 2 but favour the extremity)	
3) Non correlating Female (NCF).		6 & 7) Results skewed left or right	
4) Poor distribution of results.		8 & 9) Results uniformly higher or lower	

Tabulating these results gave us Table 17. As can be seen, the females in our experiment tended not to correlate with previous results. As this non-correlation was a consistent phenomenon we came to the conclusion that it is due to cultural bias, not the result of all females answering questions poorly or dishonestly.

Table 17: Categorisation of participant responses. Table values are in the form (day)/(nth participant for the day). Females are shown in blue.

	Good	Ok	Poor	Inverted	NCF	Skewed Left	Skewed Right	Low Mean	High Mean
Valence	1/01	1/04	1/06		3/01	4/02			
	1/02	2/01	3/03		5/01				
	1/03	2/03	3/04		5/05				
	1/05	2/04	4/01		5/07				
	2/02	4/04	4/03						
	2/05	5/02	5/09						
	2/06	5/03							
	2/07								
	2/08								
	3/02								
	4/05								
	5/04								
	5/06								
	5/08								
Total	14	7	6	0	4	1	0	0	0
Arousal	1/02	2/02	1/06		3/01	2/04	5/02	4/02	2/08
	1/03	2/03	2/01		5/01	3/02	5/03	2/07	
	1/04	2/06	3/04		5/05	4/03		1/01	
	1/05	5/06	4/01						
	2/05	5/07	5/09						
	3/03								
	4/04								
	4/05								
	5/04								
	5/08								
	Total	10	5	5	0	3	3	2	3
Dominance	1/01	1/04	2/02	5/08	3/01	2/04		1/06	2/03
	1/02	2/06	4/01		5/01	3/02		2/05	4/02
	1/03	2/07	5/09		5/05	4/03		4/04	5/03
	105	208	5/08		506				
	201	304			507				
	303	502							
	405								
	504								
total	8	6	3	1	5	3	0	3	3

For convenience Table 17 was also broken down into pie charts, Figure 259. The results echo what we found in the previous section when examining the IAPS stimuli; that is that Arousal has been fairly consistent across studies, but the Arousal and Dominance ratings are subject to a high degree of variance.

SAM Results (Valence) by Distribution

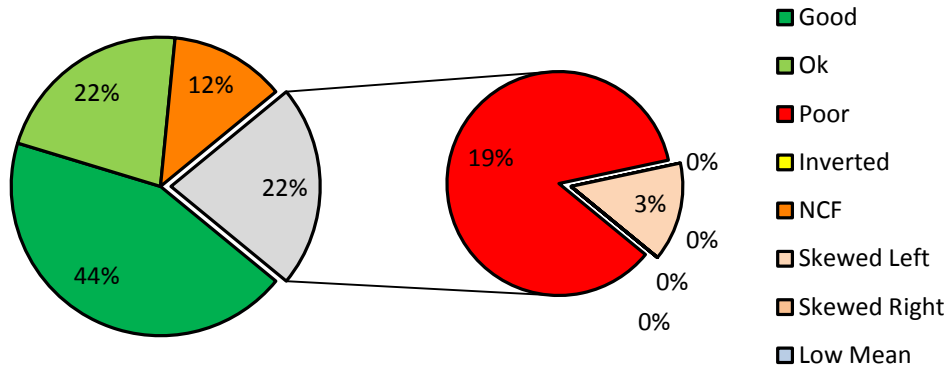

SAM Results (Arousal) by Distribution

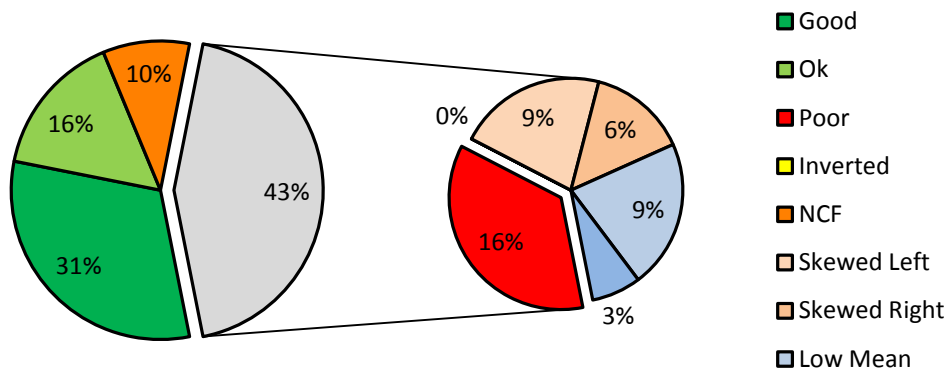

SAM Results (Dominance) by Distribution

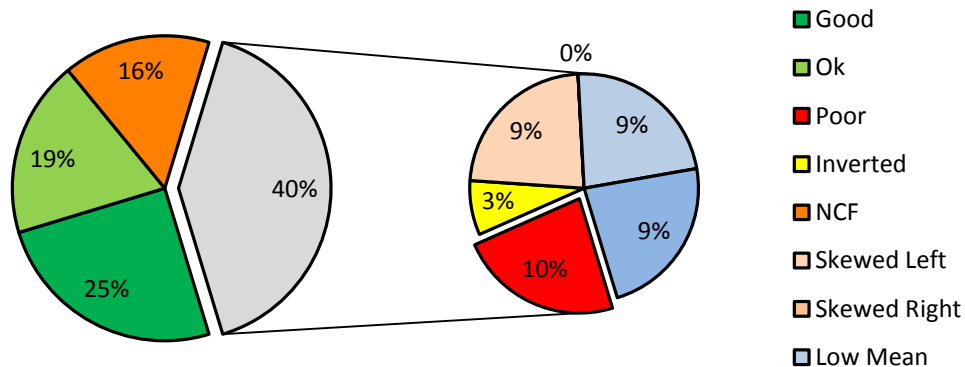

Figure 259: Table 17 displayed as a set of pie charts. The red zone indicates areas where our participants' results did not correlate with results obtained from previous studies. This could be due to significant cultural differences, errors in reporting feedback, other intangible aspects affecting the emotions of participants, or more extreme natural variance in emotional response.

10.5.1. **Summary of Effectiveness of Stimuli**

People will react differently to the same stimuli. Much research has been done into looking at "normal" responses to IAPS stimuli in various countries e.g. (Porto, 2005), (Lasaitis et al., 2008), (Moltó, Montañés, & Poy, 1999), (Verschuere, 2001), (Verschuere, 2007), (Deák, Csenki, & Révész, 2010) and many deviations from standard slide response was shown; however the IAPS slides have still been shown to be valid stimulus tools (will reliably generate emotions) in all circumstances.

At the time these experiments were conducted, there existed no comprehensive listing of IAPS norms for Australian participants, so some slides were logically rejected for use in the study if they appeared to be heavily culturally biased. For example content involving American Flags and US Dollars was excluded.

What is clear is that a variety of emotional results were definitely elicited. It is expected that there will be variation in how people respond to a stimulus, which is why the self assessment of emotion is used for training purposes, not the nature of the stimulus. The results in this section show that our slide selection did an acceptable job of eliciting a broad range of emotions, and that in general the selection was appropriate for use in Australian culture.

As the self-assessment feedback is our only information about how a person responded emotionally, it is vital to know that these reading were accurate. Our major test in this regard is comparison with previous studies. We have found good correlation with previous works, and have a common internal bias which correlates with other Australian based studies.

10.6 Visualising Results Obtained from Physiological Recordings

This work posed some interesting data visualisation problems. In this section we use data visualisation techniques to gain insight into our data via a process of ‘visual characterisation’. As it is not easy to compare many histograms or related data sets in one figure, we have invented something we call a "shotgun plot". An example of a shotgun plot is shown in Figure 260.

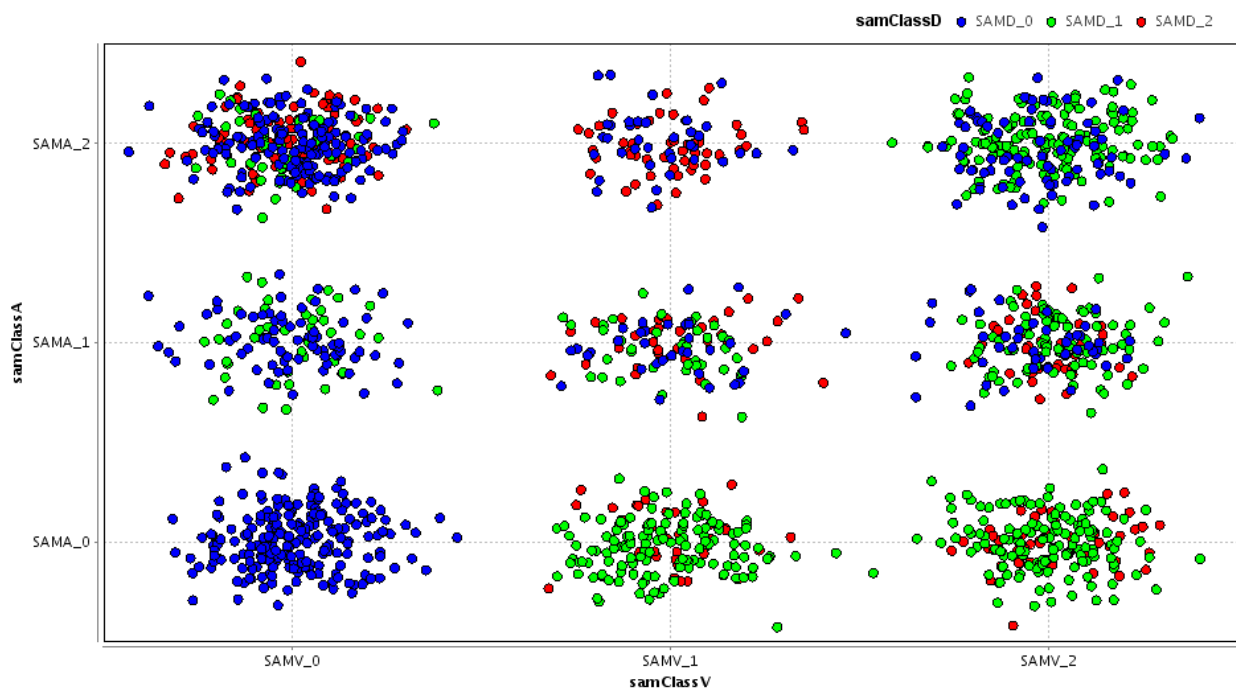

Figure 260: Example shotgun plot. The plot is broken up into discrete bins; in this case nine bins are present. The nine bins are one each for the nine areas the data has been grouped into. The nine bins are organised according to two sets of three labels which represent, in this case, the affective dimensions of Arousal (SAMA_0...SAMA_2) and Valence (SAMV_0...SAMV_2). Thus data in the three bins to the left of the graph is negative Valence (SAMV_0). Likewise data in the three bins along the top of the graph are related to positive Arousal (SAMV_2).

The colouring of the graph is the key mechanism through which it communicates information. Data items are given a colour to match their value (using the "rainbow" palate of the visible spectrum) and then plotted randomly in their bin area with a bias towards the middle (as if sprayed from a shotgun).

10.6.1. Visualising the Role of Respiration

One of the major features which continuously appeared in feature selection tasks (of heterogeneous groups) was the novel curve metric discussed in section 9.4; in particular the curve metric for the exhalation curve. We found that results of this metric which were of greater magnitude were linked to emotional states with a higher Dominance rating. This correlation is shown in Figure 261. Respiration is often linked to frustration levels (Haruki et al., 2001); which makes a correlation we observed between Dominance and respiration seem plausible.

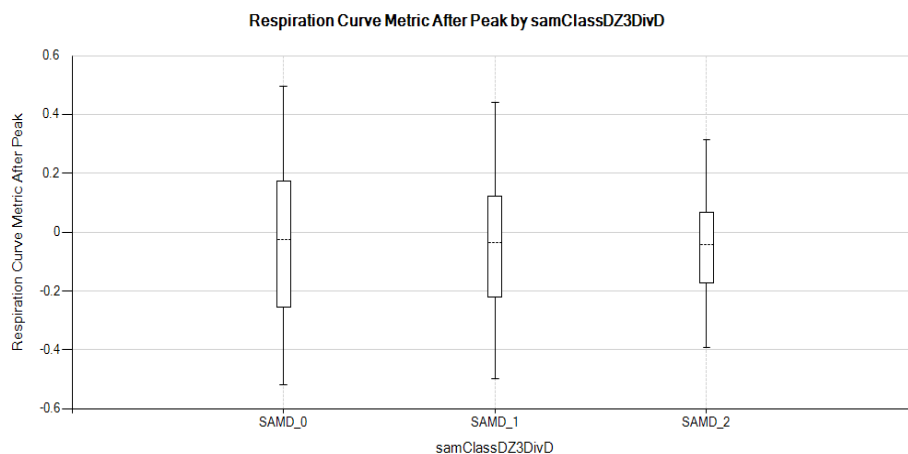

Figure 261: Exhalation curve metric for three levels of Dominance. The mean is almost constant, however the distribution of values decreases as the results move from excited (SAMD_0) to calm (SAMD_2).

Another metric “Respiration peak height from last valley” is a measurement of the amount of air intake or expulsion during the last discrete chest movement. Some results from this metric, for a typical participant, are shown in Figure 262.

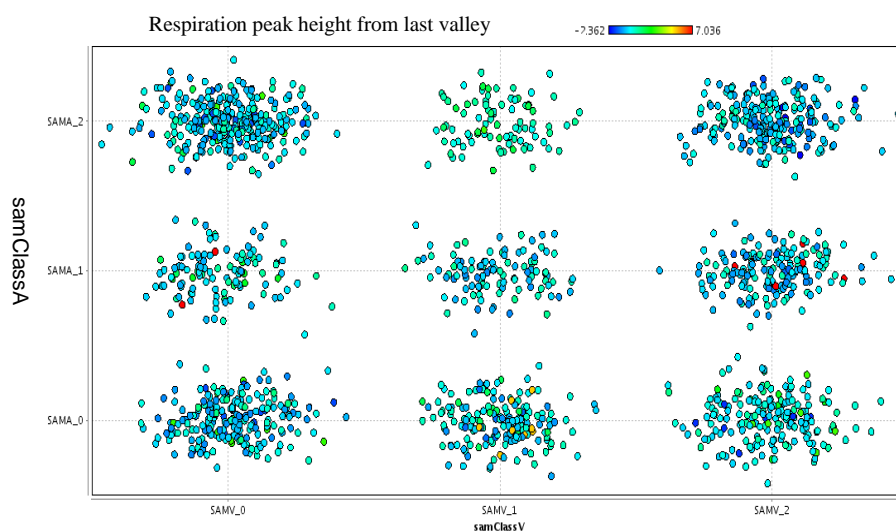

Figure 262: “Respiration peak height from last valley” metric plotted against Valence and Arousal.

Characteristics of the data:

- Data in the 20th to 50th (aqua, light green and green) percentile is omnipresent with no meaningful correlations; except for:
 - that the neutral Valence/high Arousal state is often entirely comprised of data in this range;
 - neutral Valence/neutral Arousal state lacks data from the 50th percentile.
- Data around the 70th percentile (yellow) is found almost exclusively in the neutral Valence/low Arousal state.
- Data around and above the 90th percentile (red) is found only in states of neutral Arousal with either high or negative Valence.
- Data around the 10th percentile very rarely occurs in areas of neutral Valence or Arousal.

A related metric known as "Respiration peak distance from last valley" also showed good data separation characteristics. Data from a typical participant is shown in Figure 263.

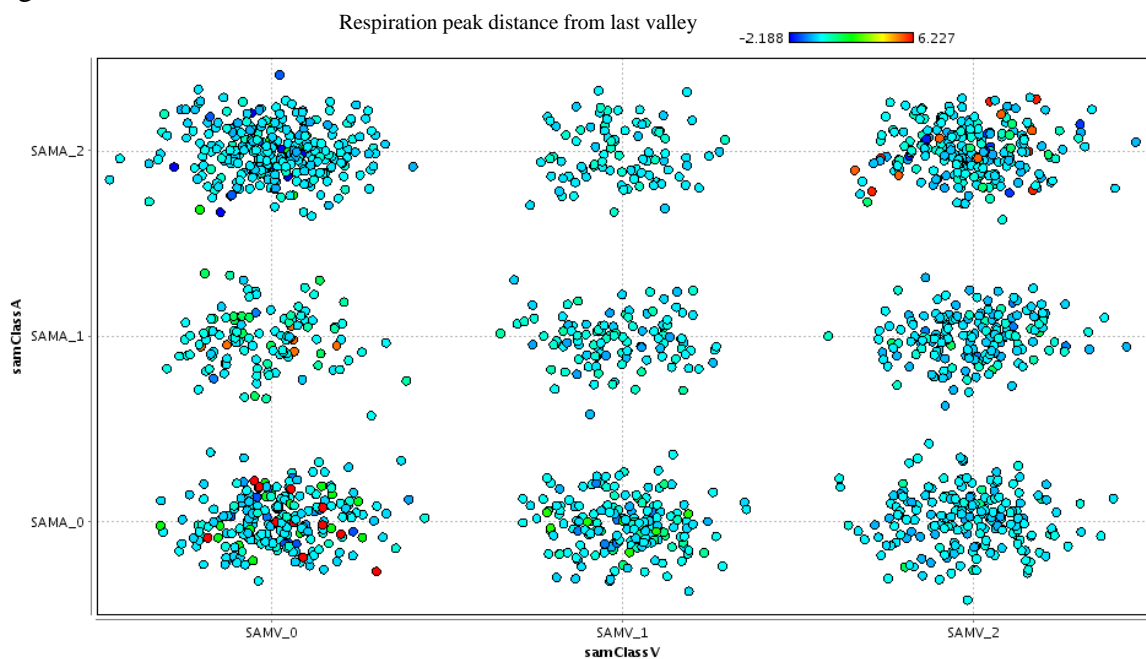

Figure 263: "Respiration peak distance from last valley" metric plotted against Valence and Arousal. The colours indicate the value of the metric.

This metric measures the duration of the last chest movement. It shows that:

- Longer (lasting) chest movements are typically present in both the low Arousal/negative Valence states and the high Arousal/positive Valence. However the same states also hold a large amount of data across the full spectrum and are not typified by such values.
- The negative Valence/high Arousal state lacks the longer chest movements.
- Many (other) states lack extreme chest movements.

10.6.2. Visualising EMG correlations

EMG is a logical candidate for discrimination of output, however in the case of person heterogeneous datasets, the (normalised) EMG reading does not clearly distinguish any emotional state. This may be due to:

- Crosstalk from nearby muscles;
- Per person uniqueness of facial expression;
- Per person differences in type of signal obtained.

Figure 264 shows a scatter plot of two typical EMG features and their ability to only very roughly categorise affective Valence states.

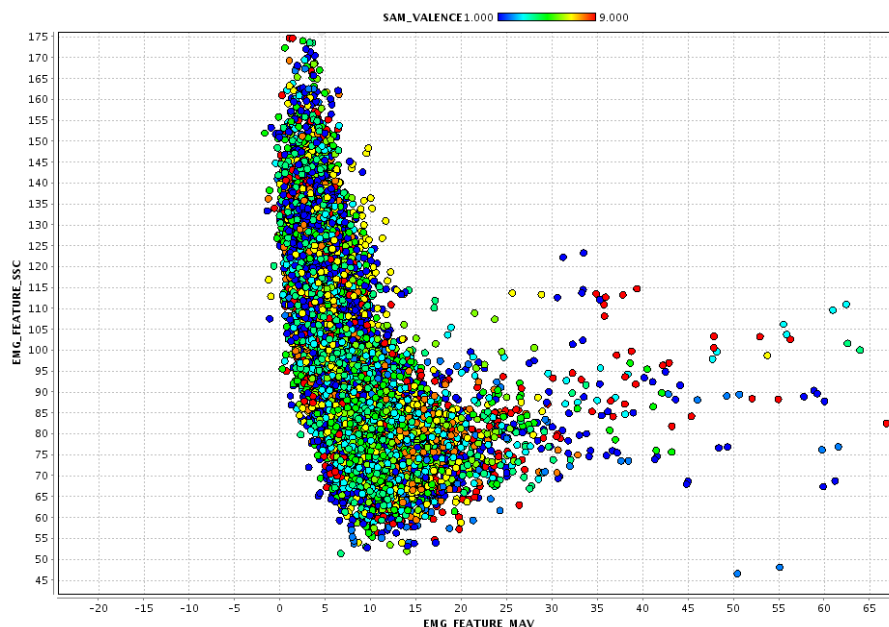

Figure 264: Scatter plot of typical EMG features and their ability to roughly categorise affective Valence states (shown in colour, blue = negative Valence, through green = neutral and red = positive). It is important to note that the graph shows heterogeneous data from multiple people. A general trend is evident in that neutral emotions yielded results lower and central to the shape of the plot.

The uniqueness of signals collected per person is a major factor in using EMG data. While on some people a correlation can be very strong, on others there is little correlation as per Figure 265.

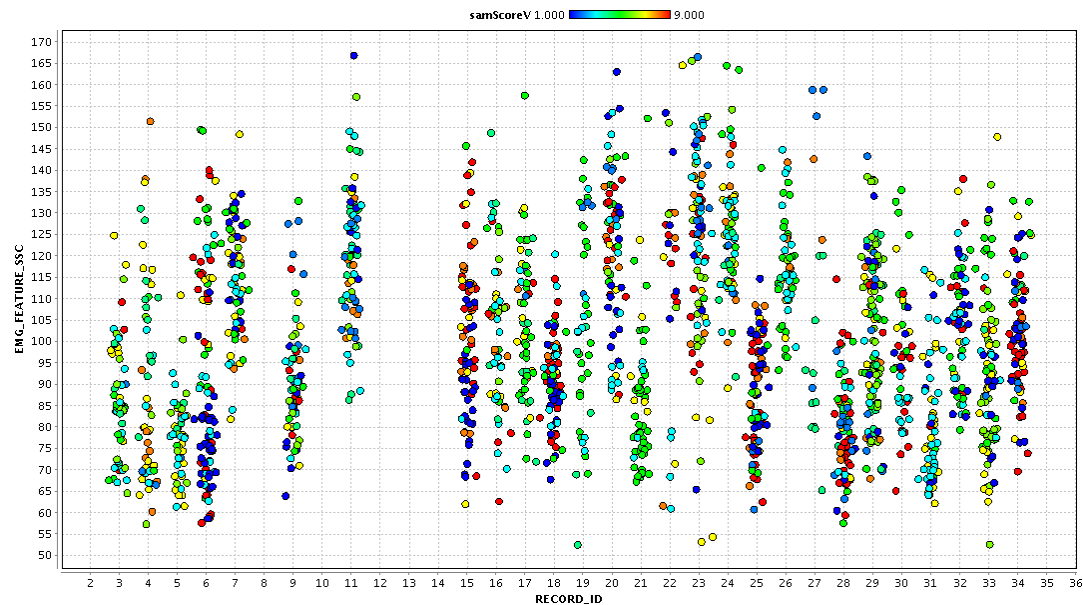

Figure 265: EMG data by Person arranged in a “waterfall”. The colour reflects Valence reported for the reading. Some participants (e.g. # 6) have EMG readings that are affected by the Valence of the stimulus; while others (e.g. #25) do not.

10.6.3. Visualising the Difficulties of Heterogeneous Classification Tasks

As will be discussed in the next chapter, PPR classification against homogenous data sets generally yielded results with 60% to 80% classification success. Finding a solution to heterogeneous data classification is a difficult task. An excellent emotion discriminator for homogenous data in this study is a galvanic skin response (GSR) signal known as "GSR Variance". Figure 266 shows how it achieves an extraordinarily good separation of the Valence of an emotion on a per person basis. However there is little to no similarity in the responses shown between people. They are extremely unique to various individuals.

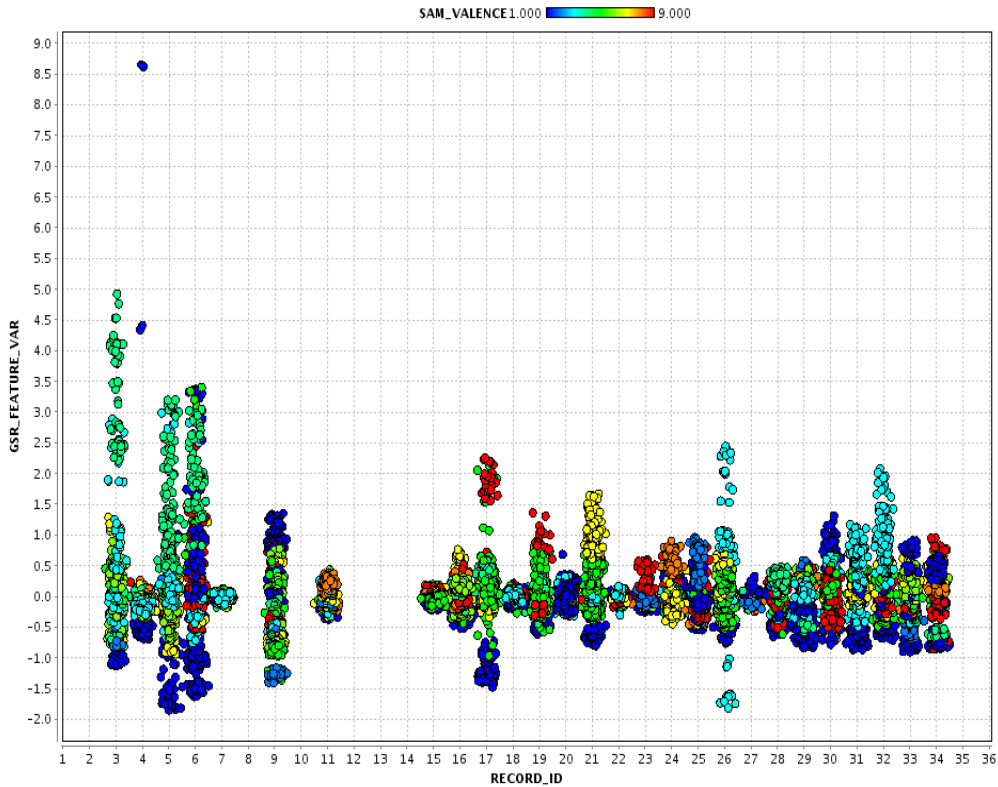

Figure 266: GSR Variance by person, coloured by Valence.

10.6.4. Visualising Time as a Factor in Obscuring Emotional Response

As would be expected, many signals are strongly correlated with emotion while the stimulus is present and fall off after the stimulus is removed. An example of this is shown in Figure 267.

DURATION OF STIMULUS by ECG Intra-Beat(P-Finish P-Finish) grouped by samScoreA.

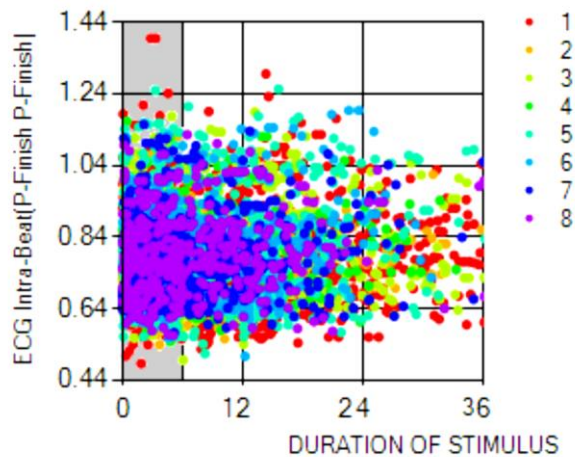

Figure 267: Falloff of ECG signal metric. The grey area is the time in the stimulus and the white was recorded during rating tasks. The points shown are sampled randomly from all participants. The colour coding shows the results of the Arousal rating.

10.7 Visualising the Feasibility of Using Multivariate Data to Separate Heterogeneous Results Sets

Sampling 300 data points from each participant's results, we produced a set of visualisations showing how combining multiple (normalised) metrics can produce distinguished emotion "regions" which appear as clusters of similar emotional responses within a scatter plot. Several of our best results are shown in Figure 268, Figure 269 and Figure 270.

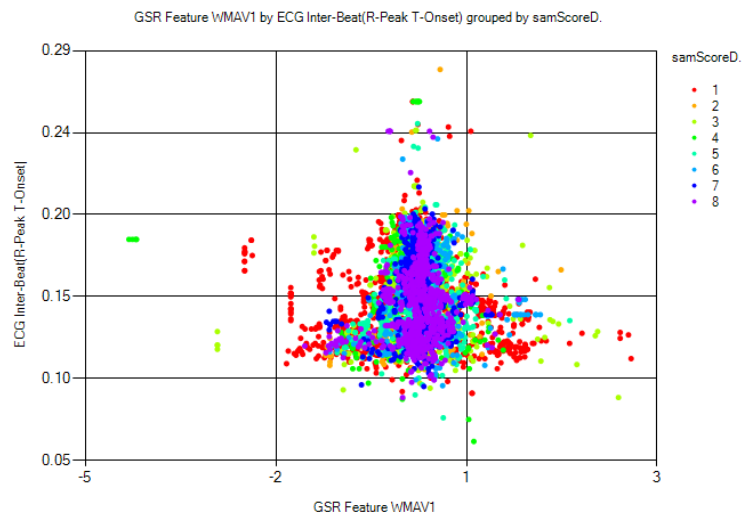

Figure 268: Using an ECG and GSR metric to separate Dominance ratings.

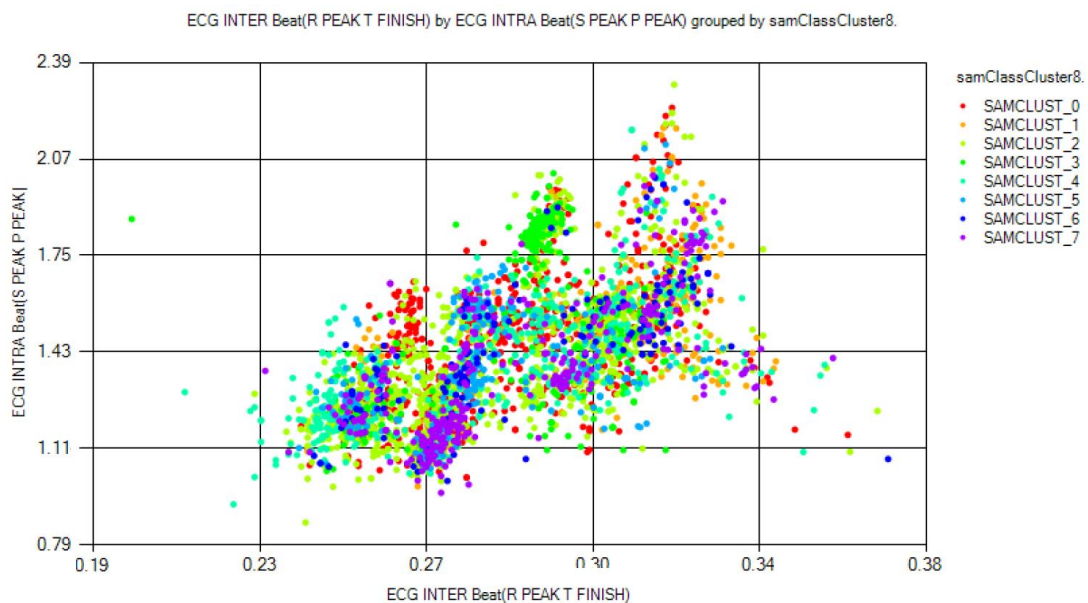

Figure 269: Using two ECG metrics to separate the clustered affective states.

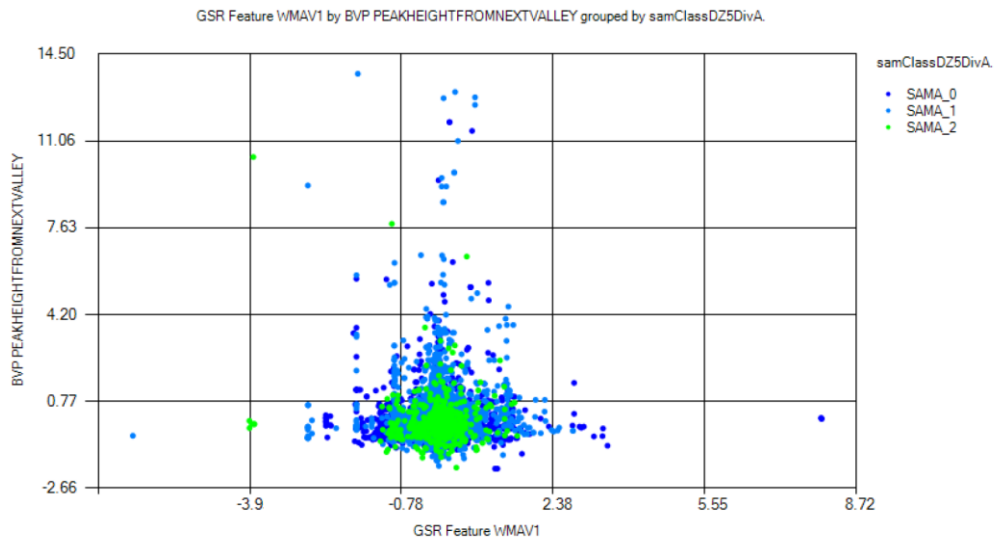

Figure 270: Using BVP and GSR Metrics to separate Arousal responses.

10.8 Sampling of Data for Classification

The sample data has an unbalanced number of samples for different classes. This can cause problems for training classifiers as biasing results towards the largest class often results in limited classifier performance (Tang, Zhang, Chawla, & Krasser, 2009). To address this problem of imbalance, we are adopting a technique of random under-sampling which has been empirically shown to be one of the most effective re-sampling methods for this type of problem (Yun-chung, 2004).

The process of random under-sampling balances the training data by randomly eliminating majority class samples until the ratio between the minority and majority classes reach a more desirable level. More details on the sub-sampling used are given in the next chapter.

10.9 A Feature Selection Investigation

As an initial step to learn something about the data, we investigated the broadest set of features that can be explored for feature extraction. This included a few extra informative signals which were incorporated to test the nature of the data being investigated.

These signals were:

- FEED_BACK_TIME_TO_RATE - The total time for the related SAM rating task to be completed;
- IN_IAPS_RATING_SCREEN - high if the user is in a rating screen, identifies the after stimulus portion of the data;
- FEED_BACK_LONGEST_KEY_DELAY - The longest pause between two consecutive key presses during the SAM rating task;
- INITIAL HESITATION - The time after the stimulus that is spent "reflecting" before the user begins the SAM rating task;
- TIME_SINCE_LAST_BUTTON - The time since the last button press during the SAM rating task.

These signals do not make sense as training data as they are not within the scope of our investigation. In this section we present which of these bits of information are selected by our feature selection process, under which condition. We then explain what this reveals in our data.

Forward feature selection via a Naive Bayes Classifier (FFS_NB) was configured for up to 20 features to be selected. The algorithm was set to stop early if after five rounds an improvement of 0.0025% was not made. The selection task was attempted for each type of label to see if any significant feature related more to a different labelling system. The algorithm's behaviour is plotted as a performance curve in a series of graphs beginning with Figure 271. The plots show the current iteration against the achieved performance metric, and is coloured by the number of attributes being examined.

Figure 271 plots the progress of the Forward Feature Selection (FFS) algorithm in refining a feature subset. A series of training arcs are present as each increase in the size of feature set (p) results in a renewed search for a good parameter set. This implies that, for the Naive Bayes Classifier, the set found is likely to worsen dramatically if features present are altered slightly. Local optima are seen for $p = 4, 6$ and 13. After $p = 13$ the system stabilises, indicating additional features are unlikely to be of benefit.

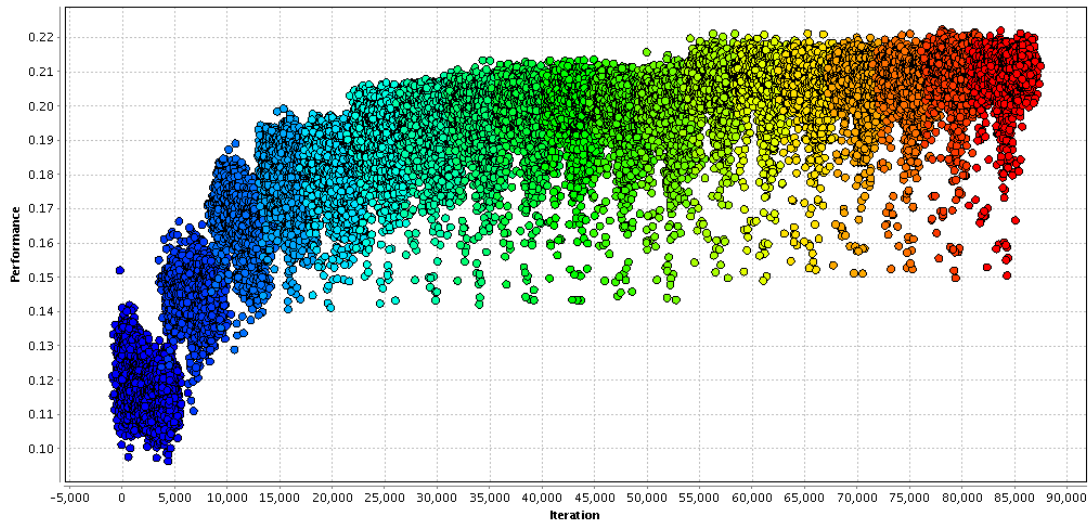

Figure 271: FFS_NB training with meta data (dead-zone = 1). Local jumps in performance are seen for $p = 4, 6$ and 13 . After $p = 13$ the system stabilises, indicating additional features are unlikely to be of benefit. The results are coloured by p as a “rainbow” spectrum over the values of p examined.

Figure 272 shows FFS performance for a dead-zone of 3 in the grid based labelling system. Again, a series of training arcs are present at each increase of p implying high sensitivity to choice of features. Local optima are seen for $p = 7$ and 15 . As p approaches 20 the system continues to grow indicating more features need to be examined.

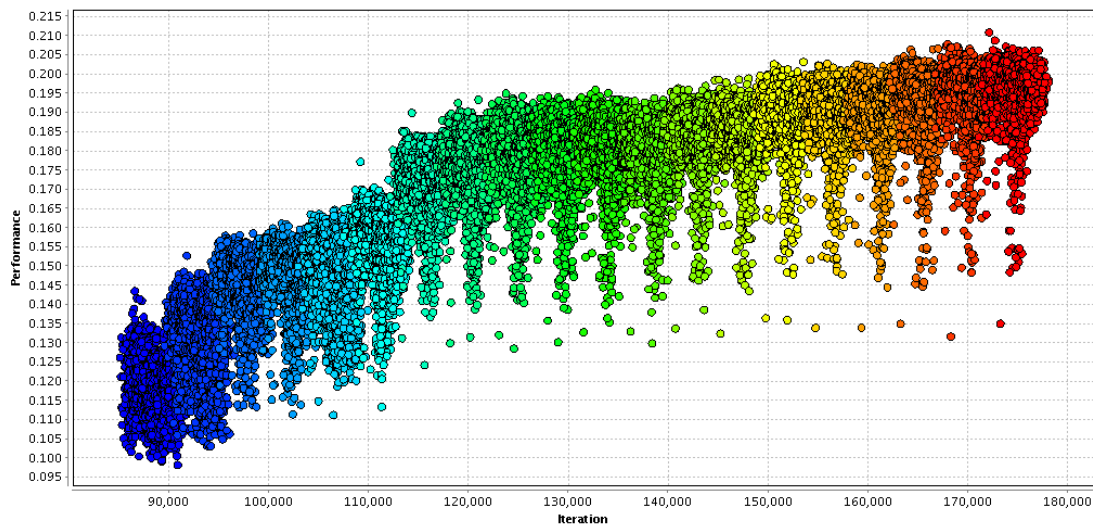

Figure 272: FFS_NB training with meta data (dead-zone = 2). Local jumps in performance are seen for $p = 7$ and 15 . As p approaches 20 the system continues to grow indicating more features need to be examined.

Figure 273 shows FFS performance for a dead-zone of 5 in the grid based labelling system. Again, a series of training arcs are present at each increase of p implying high sensitivity to choice of features. Local optima are seen for $p = 4, 6$ and 13 . As p

approaches 20 the system loses any upward trend indicating sufficient features have been examined.

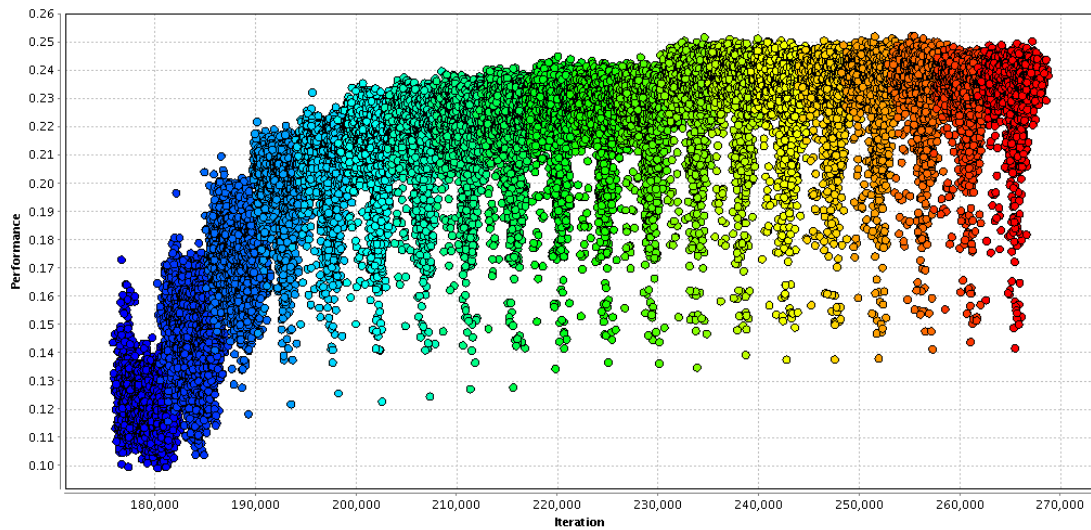

Figure 273: FFS_NB training with meta data (dead-zone = 5). Local jumps in performance are seen for $p = 4, 6$ and 13 . As p approaches 20 the system peaks indicating sufficient features have been examined.

Figure 274 shows FFS performance for a dead-zone of 3 in the grid based labelling system. Again, a series of training arcs are present at each increase of p implying high sensitivity to the choice of features. Local optima are seen for $p = 5$ and 15 . As p approaches 20 the system continues to grow indicating more features need to be examined.

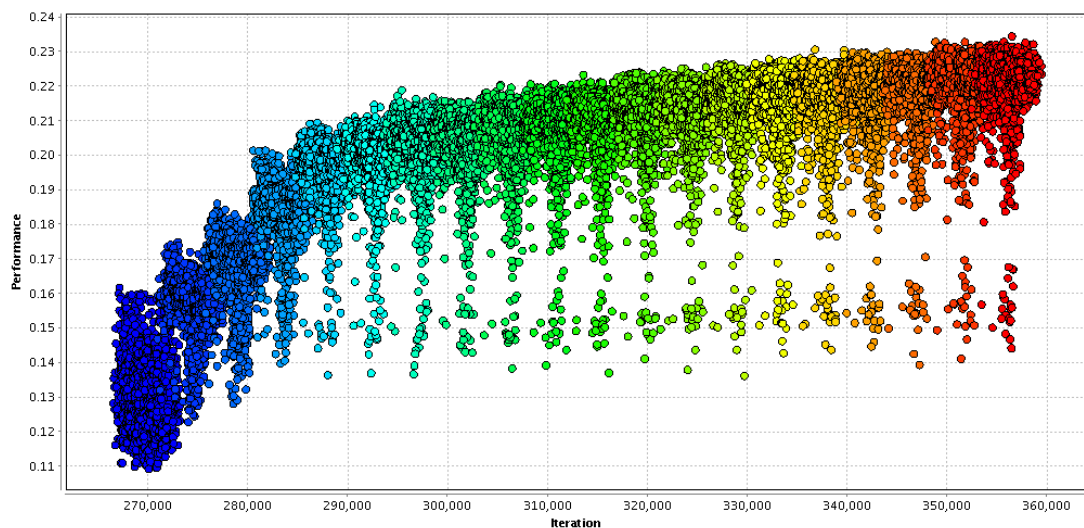

Figure 274: FFS_NB training with meta data (group based labels). Local jumps in performance are seen for $p = 5$ and 15 . As p approaches 20 the system continues to grow indicating more features need to be examined.

Table 18 shows the results of the feature selection task (FFS_NB). Difference features are shown in italic (and coloured blue), meta-features in bold (and coloured red) and the amount of reoccurrences between different labelling systems tabulated in the next column. The prominent and most frequently occurring attribute is the meta-feature **FEED_BACK_TIME_TO_RATE**. This suggests there was a strong correlation between the time with which a person can complete a rating task and the type of emotion they are feeling. This could suggest a possible further research direction into the speed of user interaction as a factor in emotion detection. The other note is that the feature **EMG_FEATURE_WAMP** appeared twice in the selection process.

Forward feature selection via a random forest classifier (FFS_RF) was run for 30,000 iterations allowing for up to 20 features to be selected. The algorithm was set to stop early if after five rounds an improvement of 0.0025% was not made. Figure 275 plots the progress of the algorithm in refining a feature subset. Jumps in performance are evident for different sizes of feature sets (p), and as expected the jumps are smaller as p increases. Notable significant improvements are found for $p = 2, 3$ and 5.

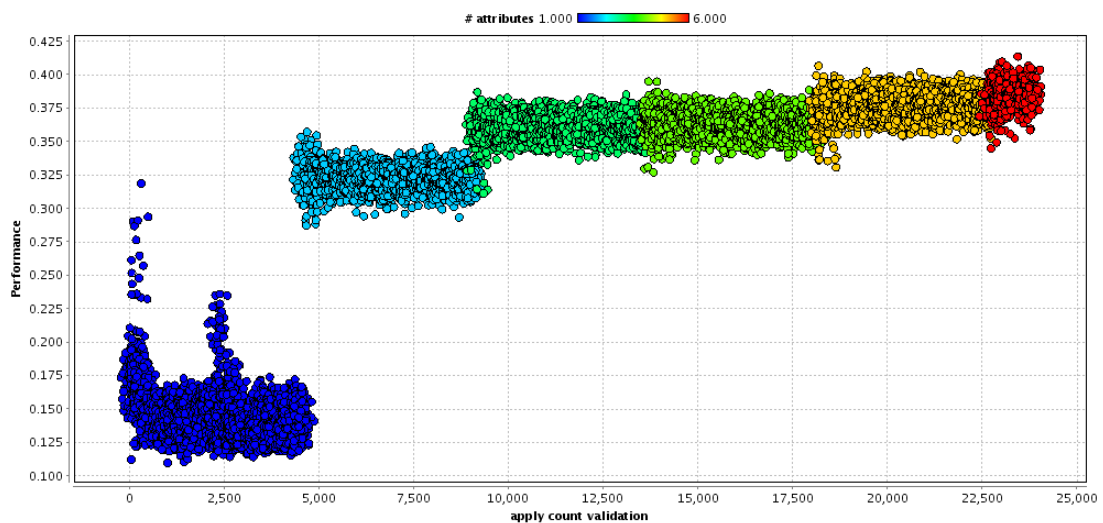

Figure 275: FFS_RF performance. Jumps in performance are evident for different sizes of feature sets (p), and as expected, the jumps are smaller as p increases. Notable significant improvements are found for $p = 2, 3$ and 5.

Table 18: Forward Feature Selection (FFS_NB) results

samClassDZ1Div9	#
EKG_INTER_BEET(P_FINISH_T_FINISH)_diff_8	
EKG_INTER_BEET(P_ONSET_R_PEAK)_NARF_diff_1	
EKG_INTER_BEET(R_PEAK_T_FINISH)_NARF	
EKG_INTRA_BEET(P_ONSET_P_ONSET)_NARF_diff_5	
EKG_INTRA_BEET(S_FINISH_Q_ONSET)	
EKG_INTRA_BEET(S_PEAK_S_FINISH)_diff_0	
EKG_INTRA_BEET(T_FINISH_P_FINISH)_NARF	
EKG_INTRA_BEET(T_FINISH_Q_PEAK)_NARF	
EKG_INTRA_BEET(T_ONSET_Q_ONSET)_NARF_diff_9	
EMG_FEATURE_ARV_10_diff_9	
EMG_FEATURE_ARV_9_diff_8	
EMG_FEATURE_WAMP	2
FEED_BACK_TIME_TO_RATE	4
GSR_FEATURE_IGSR	
RESP_PEAKSLOPEBEFOREBYAREAUNDERCURVE_diff_2	
TEMP_CORECT_FROM_REST_MAV_diff_4	

samClassDZ3Div9	#
BVP_PEAKSLOPEAFTERBYAREAUNDERCURVE_diff_4	
EKG_INTER_BEET(P_PEAK_R_PEAK)_diff_3	
EKG_INTER_BEET(Q_ONSET_T_PEAK)_diff_8	
EKG_INTER_BEET(Q_PEAK_T_ONSET)_diff_0	
EKG_INTER_BEET(R_PEAK_T_ONSET)_diff_4	
EKG_INTRA_BEET(Q_ONSET_P_FINISH)_diff_9	
EKG_INTRA_BEET(Q_ONSET_T_PEAK)_NARF	
EKG_INTRA_BEET(R_PEAK_P_PEAK)_NARF_diff_3	
EKG_INTRA_BEET(R_PEAK_S_FINISH)_diff_6	
EKG_INTRA_BEET(R_PEAK_T_FINISH)	
EKG_INTRA_BEET(R_PEAK_T_ONSET)_diff_4	
EKG_INTRA_BEET(T_ONSET_P_PEAK)_NARF_diff_5	
EKG_QT_F_diff_0	
EMG_FEATURE_ARV_5_diff_6	
EMG_FEATURE_MAV	
EMG_FEATURE_WAMP	2
FEED_BACK_TIME_TO_RATE	4
GSR_FEATURE_SSI	
RESP_PEAKSLOPEAFTERBYAREAUNDERCURVE	
RESP_PEAKSLOPEBEFOREBYAREAUNDERCURVE_diff_7	

samClassDZ5Div9	#
EKG_INTRA_BEET(P_ONSET_S_PEAK)_diff_4	
EKG_INTRA_BEET(S_PEAK_Q_ONSET)	
EKG_INTRA_BEET(S_PEAK_R_PEAK)	
EKG_INTRA_BEET(T_PEAK_Q_ONSET)	
EKG_QT_C_diff_9	
EMG_FEATURE_ARV_1	
FEED_BACK_TIME_TO_RATE	4

samClassCluster8	#
EKG_INTER_BEET(P_FINISH_Q_ONSET)_NARF_diff_9	
EKG_INTER_BEET(P_PEAK_T_ONSET)_diff_5	
EKG_INTER_BEET(Q_ONSET_T_ONSET)_diff_6	
EKG_INTER_BEET(R_PEAK_S_PEAK)_diff_2	
EKG_INTER_BEET(R_PEAK_S_PEAK)_diff_9	
EKG_INTER_BEET(S_PEAK_S_FINISH)	
EKG_INTER_BEET(S_PEAK_T_PEAK)_diff_4	
EKG_INTER_BEET(T_ONSET_T_FINISH)_diff_2	
EKG_INTRA_BEET(P_FINISH_R_PEAK)_NARF_diff_7	
EKG_INTRA_BEET(P_ONSET_T_FINISH)	
EKG_INTRA_BEET(Q_ONSET_T_FINISH)_NARF_diff_7	
EKG_INTRA_BEET(Q_ONSET_T_FINISH)_diff_1	
EKG_INTRA_BEET(R_PEAK_T_ONSET)_NARF_diff_7	
EKG_INTRA_BEET(S_PEAK_P_PEAK)_diff_7	
EKG_INTRA_BEET(T_FINISH_T_PEAK)_diff_8	
EKG_INTRA_BEET(T_ONSET_S_PEAK)_diff_9	
FEED_BACK_TIME_TO_RATE	4
GSR_FEATURE_MMAV1	
TEMP_BL_SMOOTHED_MAV_diff_0	

Given FEED_BACK_TIME_TO_RATE has occurred with a high enough prevalence to suggest it has a significant role, it was removed from the test set to see if any other descriptive features might occur under feature selection tasks. The experiments were re-run and no extra features were selected.

Another round of feature selection experiments was conducted along the same lines as the preliminary experiments shown so far, but this time the difference based features were removed. The forward feature selection using Naive Bayes classifier for grid labels produced one extra descriptive feature, IN_IAPS_RATING_SCREEN. The set produced was:

- BVP_PEAK_HEIGHT_FROM_NEXT_VALLEY;
- EKG_INTRA_BEET(P_PEAK_T_PEAK);
- EKG_INTRA_BEET (T_FINISH_S_PEAK);
- EMG_FEATURE_ARV_1;
- EMG_FEATURE_VAR;
- FEED_BACK_TIME_TO_RATE;
- GSR_FEATURE_SSI;
- IN_IAPS_RATING_SCREEN;
- RESP_PEAK_SLOPE_AFTER_BY_AREA_UNDER_CURVE.

The presence of FEED_BACK_TIME_TO_RATE most likely indicates that some states cause people to perform the rating task in a quicker or slower manner. This may have something to do with particular emotional states being clearer (thus quicker to describe), or other states may promote or inhibit general speeds of task completion. However such possibilities are not of concern in the feature extraction process.

The presence of IN_IAPS_RATING_SCREEN correlates with other informal investigations and related data analysis in the next two chapters. The implication is that there is a good case for treating data collected during the stimulus and after the stimulus in a separate manner.

10.10 Conclusion

This chapter began by examining how we would group our SAM ratings into discrete emotional states. Two methods were examined. One divided the emotional states into a grid which could easily be queried by software with questions like “did the user find this to be pleasant?”. The second removed all a-priori knowledge of the emotion space and performed a grouping based on statistical properties of the ratings. We will examine which of these is the better solution in the next chapter.

In the next part(s) of this chapter we demonstrated the effectiveness of the IAPS stimuli in stimulating human emotion and we established that for the most part our participants reacted to the stimulus in a manner predicted by previous works. We found some slides which did not gain the reactions as were expected from previous studies and found that these slides were all of similar theme(s). We proposed that the differences we discovered were due to a cultural bias in our work which is both an expected and normal outcome. We then examined a few case studies of slides for which the effect was most extreme.

We then presented some visualisations and graphs of various trends we observed in our physiological recordings. This was done for two reasons:

- Verifying that expected correlations were present;
- Determining if any of the new metrics we created revealed any new information.

In this respect we found that the expected trends were present and one of our new metrics (the novel curve metric discussed in 9.4) did show some correlation with Dominance ratings. This is an important finding because Dominance is traditionally one of the more difficult ratings to find correlations with.

Lastly we performed feature selection task on all the data in order to find a good subset of features to use in the classification tasks which is the focus of the next chapter.

11.0 Classification of Data

"Try to learn something about everything and everything about something."

- Thomas Henry Huxley (1825-1895)

In this chapter we wish to answer the following four questions:

1. Of the candidate classifiers, which best performs this task?
2. Which features should be used for classification purposes?
3. How does the performance of classifiers vary for our different types of class labels?
4. How does the performance of classifiers vary across participants?

A primary question in determining the performance of our physiological pattern recognition system is number 1 (“Of the candidate classifiers, which best performs this task?”). We investigated five different classifiers and determined which of these best suits our needs. The classifiers examined were:

- The random forest classifier;
- The naïve Bayes classifier;
- The artificial neural network;
- The k nearest neighbour classifier;
- The support vector machine.

As the results in this chapter show, the random forest classifier proved the most accurate, and the cluster based labelling system also proved to be superior over the grid based label system. Hence question 4 was examined using random forests trained with cluster based labels.

Searching for comparable works to compare our results against, we required works with similar amounts of (weakly induced) emotional states, also conducted on multiple participants (at least 10). These requirements, analysed in the literature review, gave us the studies to which this portion of the work is most applicable, namely:

- Nasoz et al., (Nasoz, Alvarez, Lisetti, & Finkelstien, 2003);
 - 24 participants, 6 emotional states, 69% accuracy.
- Takahashi (Takahashi, 2004);
 - 12 participants, 6 emotional states, 42% accuracy.
- Lisetti & Nasoz (Lisetti & Nasoz, 2004).
 - 29 participants, 6 emotional states, 84% accuracy.

In comparison, our highest classification accuracy (detailed later in this chapter) is 59.96% for grid based labels and 64.43% for cluster based labels.

Our work faces a task more difficult than that of these studies as we are attempting to differentiate between 8 and 9 emotional states, however, despite this, our results appear to be in the middle range of the performances obtained by the other available studies.

We begin this chapter with the results of our investigation into which features should be used for training purposes.

11.1 Which features should be used?

This research, like many other studies, has produced a very large number of features. Not all of the features will be relevant to the emotional phenomena being studied and many will correlate significantly, causing redundancies.

We wish to establish a small set of primary features which can be used. This is achieved by eliminating features with little or no predictive information and removing redundant features which are highly correlated to other more useful features. This process of feature selection should give us the following benefits:

- Allow for classifier models which have increased accuracy and should generalise better to unseen points (prevent classifiers from over fitting the data);
- Increase the computational efficiency of the resulting classifiers;
- Improve the comprehensibility of the resulting classifiers.

Further, finding the correct subset of predictive features is an important research question in its own right as it may reveal new information regarding physiological responses associated with various emotional states.

There are two major approaches used to reduce the dimensionality of data sets, *feature selection* and *feature extraction* (Guyon & Elisseeff, 2003). Feature selection techniques attempt to find a representative subset of the original features. Feature extraction techniques attempt to transform the highly dimensional feature base into a

set of features of fewer dimensions. Feature selection can be broken down into two major approaches, feature ranking and subset selection.

Many common feature extraction techniques used in physiological pattern recognition are reviewed by Fodor (Fodor, 2002).

Table 19: survey of dimensionality reduction techniques in affective signal processing.

Ref	P	# Emotional States	Sample Hz	Signals	# Features	Reduction Algorithm	Classifier	Classification Accuracy
(Yannakakis & Hallam, 2008)	72	2 (detect fun)	256Hz	HR, BVP, SC	20	ANOVA	SVM, MLP	70%
(Leon & Clarke, 2007)	8	3 (heterogeneous)	?	?/GSR	5	DBI	AANN	71%
(Healey & Picard, 2005)	9	3 (levels of stress)	496Hz (ECG), 31Hz (GSR, RS), 15.5Hz (EMG)	ECG, EMG, GSR, RS	22	Fisher	LDA	97%
(Kim & Ande, 2008)	3	4	256Hz(ECG), 32Hz otherwise	ECG, EMG, RS, GSR	110	SBS	LDA, EMDC	70/95%
(Picard, Vyzas, & Healey, 2001)	1	8	20Hz	EMG, BVP, GSR RS	40	SFS, Fisher	LDA	81%
(Scheirer, Fernandez, Klein, & Picard, 2002)	24	2 (detect frustration)	20Hz	EMG, BVP, GSR	5	Viterbi	HMM	64%

We do not know yet which label system we wish to apply from the two best candidates discovered in Section 10.1. As such we will perform feature selection for both the grid and the cluster labels. These two label systems will henceforth be referred to as grid and cluster based labels respectively.

Forward feature selection (see Section 2.5.1) via a Naive Bayes Classifier (FFS_NB) was configured for up to 30 features to be selected. Given the size of our dataset, this feature selection method was chosen for its time complexity in relation to the number of features being examined. The algorithm was set to stop early if after five rounds an improvement of 0.0025% was not made. The selection task was repeated for each type of label to see if any significant feature related more to a different labelling system. The algorithm's behaviour is plotted as a performance curve in a series of graphs, Figure 276 and Figure 277. The plots show the current iteration against the achieved performance metric, and are coloured by the number of attributes being examined.

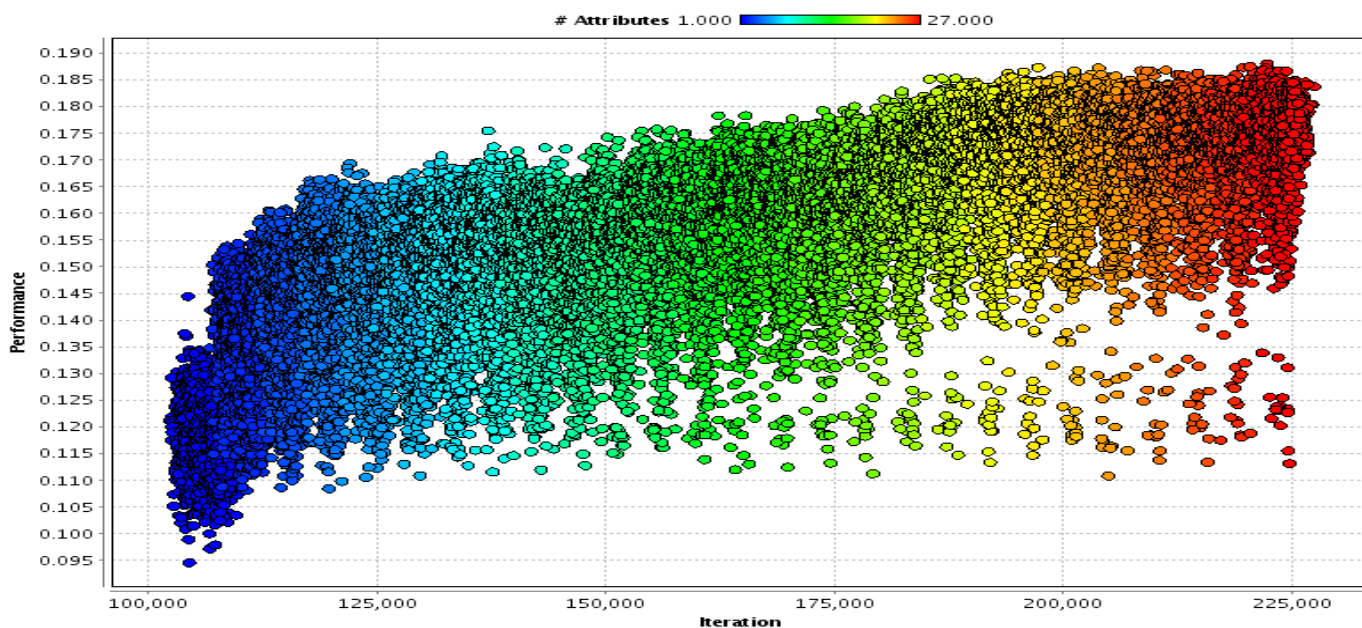

Figure 276: Forward feature selection (FFS) results obtained using a naive Bayes classifier on the grid based labels (samClassDZ3Div9). Each point represents the performance of a unique subset of features as tested in the FFS algorithm. The X axis represents the number of iterations the FFS algorithm has passed through.

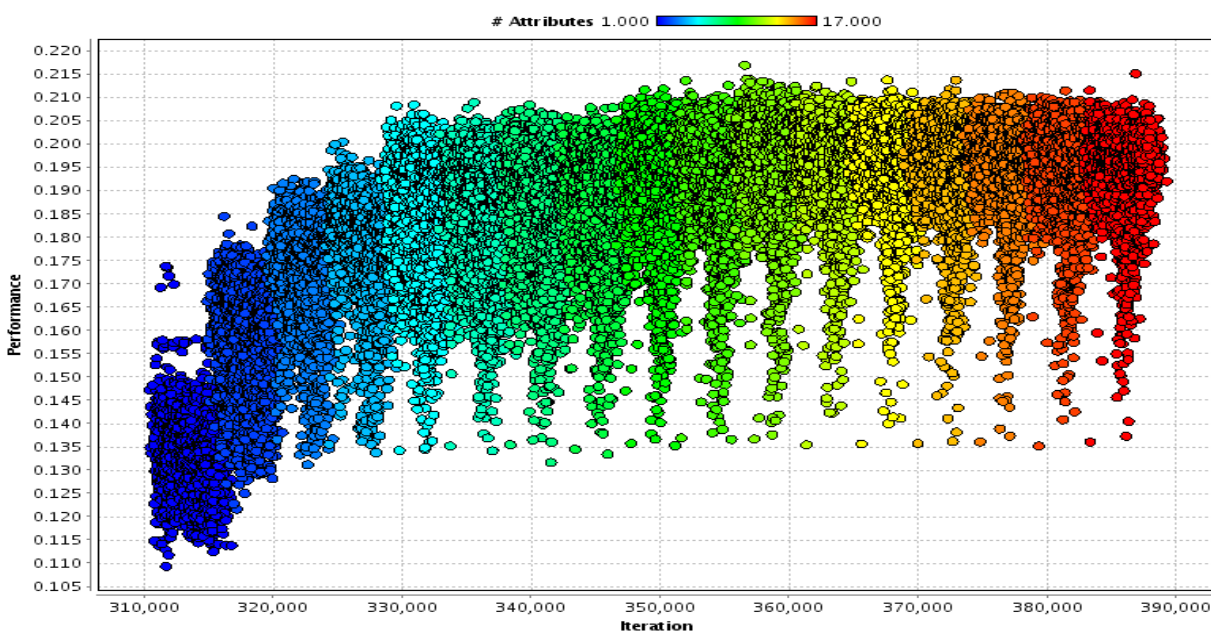

Figure 277: Forward feature selection (FFS) results obtained using a naive Bayes classifier on the cluster based Labels (samClassCluster8). Each point represents the performance of a unique subset of features as tested in the FFS algorithm. The X axis represents the number of iterations the FFS algorithm has passed through.

The resulting feature selection sets are shown in Table 20. Notably the 8 category grouped labels reached an optimal feature set with fewer features ($n=11$) than the 9 way grid divided data ($n=21$). The difference values appeared often under the

selection procedure, most commonly for ECG data. Both sets used EMG, ECG and GSR; however the 9 way grid divided data used respiration and temperature data as well.

Table 20: Results of feature selection for grid and cluster based Labels. The cluster based label system required 11 features before no significant improvement was found, while the grid based system required 21 features.

Grid based Labels	Cluster Based Labels
EKG_INTER_BEET(R_PEAK_S_FINISH)	EKG_INTRA_BEET(P_ONSET_P_PEAK)
EKG_INTRA_BEET(T_ONSET_P_PEAK)	EMG_FEATURE_SSC
RESP_PEAKHEIGHTFROMNEXTVALLEY	GSR_FEATURE_RMS
EMG_FEATURE_ARV_10	EKG_INTRA_BEET(P_ONSET_S_PEAK)_NARF
EKG_INTER_BEET(P_FINISH_T_ONSET)_diff_9	EKG_INTRA_BEET(P_PEAK_Q_PEAK)_NARF
EKG_INTER_BEET(Q_ONSET_T_PEAK)_diff_8	EKG_INTER_BEET(R_PEAK_T_FINISH)_diff_2
EKG_INTRA_BEET(S_PEAK_R_PEAK)_diff_9	EKG_INTRA_BEET(Q_ONSET_S_FINISH)_diff_6
EKG_INTRA_BEET(S_PEAK_T_PEAK)_diff_8	EKG_INTRA_BEET(S_FINISH_S_PEAK)_diff_5
RESP_PEAKHEIGHTFROMNEXTVALLEY_diff_9	EKG_INTRA_BEET(S_PEAK_T_FINISH)_diff_6
RESP_PEAKWIDTH_diff_0	EKG_INTRA_BEET(S_PEAK_T_FINISH)_diff_8
RESP_DISTANCETILLNEXTPEAK_diff_0	EKG_INTRA_BEET(S_PEAK_R_PEAK)_NARF_diff_9
EMG_FEATURE_ZC_diff_6	
EMG_FEATURE_ZC_diff_7	
TEMP_CORECT_FROM_REST_MAV_diff_3	
EKG_INTRA_BEET(P_FINISH_Q_PEAK)_NARF_diff_0	
EKG_INTRA_BEET(P_FINISH_T_FINISH)_NARF_diff_4	
EKG_INTRA_BEET(P_FINISH_T_PEAK)_NARF_diff_9	
EKG_INTRA_BEET(P_PEAK_P_PEAK)_NARF_diff_5	
EKG_INTRA_BEET(R_PEAK_S_PEAK)_NARF_diff_9	
EKG_INTRA_BEET(S_PEAK_T_ONSET)_NARF_diff_3	
EKG_INTRA_BEET(T_ONSET_S_PEAK)_NARF_diff_3	

The features that were selected are not surprising. They span EKG, EMG & GSR data, which would be a logical necessity given the emotional links discussed in the literature review. We used a heterogeneous data set for the feature selection task, as we wished to discover features of common applicability to multiple people. In the next section we investigate how these features perform when used to train classifiers in a homogeneous environment.

11.2 How does the performance of classifiers vary for our different types of class labels?

We wish to compare the grid and the cluster based labelling systems and choose which one will be the system used for the rest of our comparative experiments.

The grid based labelling is a very logical system as we can easily query it with questions like “was that a good feeling?”, “did the person have a significant reaction to the stimulus?”. Such information could be useful to entertainment systems modifying content in real time to suit a user’s emotional reactions. On the other hand our k-means based division of the data (group based labels) is a less useful metric from an analysis point of view, but it does encapsulate more information in fewer bins.

The previously identified features were extracted from the heterogeneous set of all our participants’ data. The results shown in the previous section are therefore heterogeneous in nature and not indicative of the performance which can be expected when a classifier is trained to identify the emotion of only one person (the homogenous case). As an initial test, we performed an exercise in tuning a random forest classifier (our strongest classifier) for our individual participants using both grid and cluster based labels. A scatter plot of the results is shown in Figure 278. Our findings were that cluster based labels performed the strongest most frequently; giving a more accurate classification 73% of the time, or being equal for 9% of cases.

We repeated the test using a different classifier, the Support Vector Machine (SVM). The SVM was run in several configurations with varying degree of success, but the choice of label continuously proved to be a major factor in the final performance. A scatter plot of the results is shown in Figure 279. The cluster based labels were superior 68% of the time, and roughly equal 9% of the time.

The cluster based labels are often superior and require fewer features to train the classifier which makes them an obvious preferred choice. Additionally the cluster

labels include Dominance information, which is important to our research goals. However the non-intuitive nature of the results might limit the practical use of the labelling system. For this reason we shall continue to compare between the two labelling systems through this chapter and the next.

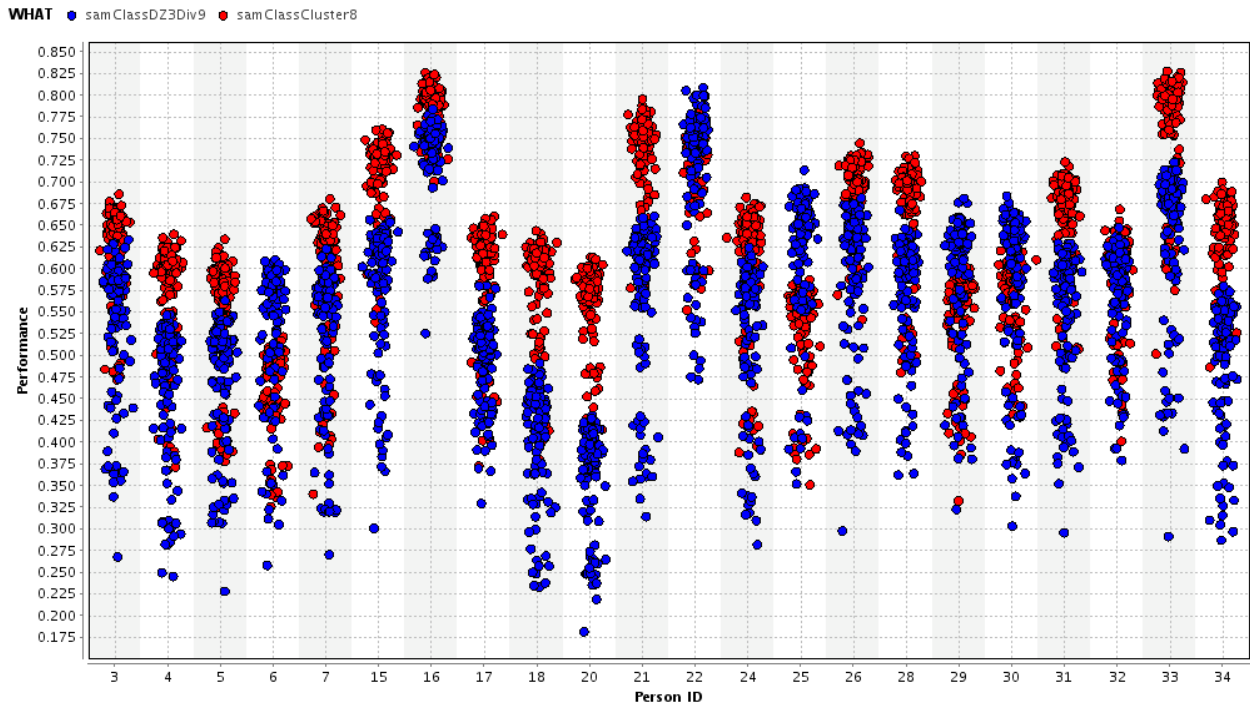

Figure 278: Performance over all participants of a series of random forest classification tasks. Note: grid labels are in blue and cluster labels are red.

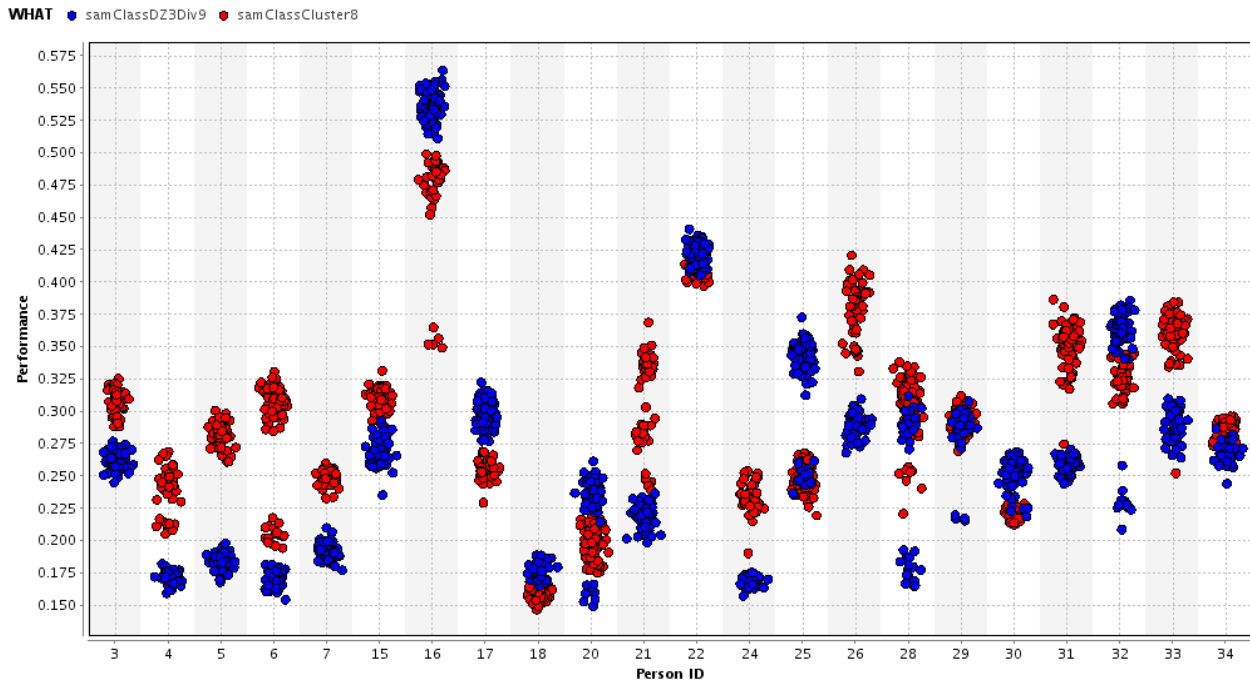

Figure 279: Performance over all participants of a series of Support Vector Machine (SVM) classification tasks. Note: grid labels are in blue and cluster labels are red.

11.3 Naive Bayes Classifier

The naive Bayes classifier was tested for performance across our participants. The results of these experiments averaged around 42% for Grid based labels and 48% for cluster based labels. This makes the naive Bayes classifier about 17% less accurate than the random forest classifier. However the naive Bayes classifier did perform well for a small section of our population, as shown in Figure 280

Performance by Label Type (NB)

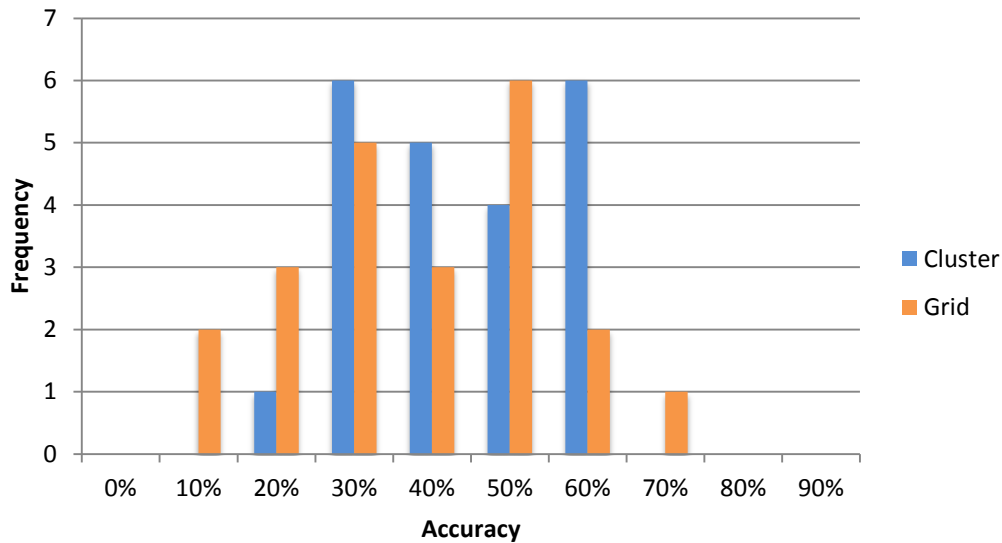

Figure 280: Performance of naive Bayes classifiers.

Confusion matrices for both label schemes are shown in Figure 281 and Figure 282. The classifier for the grid based classification scheme had poor results in predicting an emotion (PPV = 32% to 58%) but is an excellent tool for establishing if someone is not in a given emotion (NPV = 87% to 97%, α = 3% to 10%). The state of being in negative Valence with low Arousal stands out as being the easiest to predict (PPV = 58%). These results were significantly higher than chance guessing (11%).

The classifier for the cluster based classification scheme had adequate results in predicting an emotion (PPV = 42% to 54%) and, like the grid labels, is also an excellent tool for establishing if someone is not in a given emotion (NPV = 87% to 97%, α = 3% to 10%). Clusters 2 and 5 stand out as being the easiest to predict (PPV = 51% to 54%) and are shown in Figure 283.

		PREDICTION									α ,	β ,	TP,	FN,	FP,	TN
		SAM9_1	SAM9_2	SAM9_3	SAM9_4	SAM9_5	SAM9_6	SAM9_7	SAM9_8	SAM9_9						
ACTUAL	SAM9_1	765	266	256	305	172	50	277	198	108	5%	68%	765	1632	557	10497
	SAM9_2	94	823	130	289	195	36	144	209	108	9%	59%	823	1205	1004	10419
	SAM9_3	39	98	417	71	81	20	111	85	121	6%	60%	417	626	746	11662
	SAM9_4	94	188	60	590	199	87	190	90	95	10%	63%	590	1003	1240	10618
	SAM9_5	34	114	88	158	785	68	175	101	112	9%	52%	785	850	1062	10754
	SAM9_6	14	65	31	62	44	361	39	37	34	3%	47%	361	326	355	12409
	SAM9_7	77	85	23	156	131	15	658	82	84	10%	50%	658	653	1159	10981
	SAM9_8	122	139	75	136	140	31	129	796	70	8%	51%	796	842	886	10927
	SAM9_9	83	49	83	63	100	48	94	84	515	6%	54%	515	604	732	11600
PPV		58%	45%	36%	32%	43%	50%	36%	47%	41%						
NPV		87%	90%	95%	91%	93%	97%	94%	93%	95%	Accuracy = 42.45%					

Key

Correct	Very Similar	Relevant	Unrelated	Oposing
---------	--------------	----------	-----------	---------

TP = True Positives, FN = False Negatives, FP = False Positives, TN = True Negatives

PPV = Positive Predictive Value, NPV = Negative Predictive Value,

α = False Positive Rate, β = False Negative Rate

Figure 281: Summary confusion matrix for grid based labels trained via a naive Bayes classifier. As not all predictions are equally wrong, the matrix is displayed in a colour coded manner to indicate the nature of each error. The rightmost column provides summary statistics for each label in terms of True Positives, False Positives, False Negatives and True Negatives. The last row gives individual and total classification accuracies. The coloured areas are akin to a bar graph which shows that cells portion of the total predictions for the associated label. The colour represents the nature of the guess, blue for correct, two greens for level of similarity, pink for an unrelated state and red for an opposing state.

		PREDICTION								α ,	β ,	TP,	FN,	FP,	TN
		CLUST0	CLUST1	CLUST2	CLUST3	CLUST4	CLUST5	CLUST6	CLUST7						
ACTUAL	CLUST0	809	135	117	103	126	108	37	152	10%	49%	809	778	1121	9760
	CLUST1	122	686	153	133	132	64	143	69	8%	54%	686	816	834	10132
	CLUST2	173	178	913	91	161	100	99	114	8%	50%	913	916	871	9768
	CLUST3	122	102	103	589	125	104	31	80	6%	53%	589	667	631	10581
	CLUST4	193	132	191	89	770	115	108	234	8%	58%	770	1062	879	9757
	CLUST5	126	78	81	127	111	756	78	115	6%	49%	756	716	652	10344
	CLUST6	179	156	86	40	92	100	741	126	5%	51%	741	779	597	10351
	CLUST7	206	53	140	48	132	61	101	729	8%	50%	729	741	890	10108
PPV		42%	45%	51%	48%	47%	54%	55%	45%						
NPV		93%	93%	91%	94%	90%	94%	93%	93%	Accuracy = 48.07%					

Key

Correct	Very Similar	Relevant	Unrelated	Oposing
---------	--------------	----------	-----------	---------

TP = True Positives, FN = False Negatives, FP = False Positives, TN = True Negatives

PPV = Positive Predictive Value, NPV = Negative Predictive Value,

α = False Positive Rate, β = False Negative Rate

Figure 282: Summary confusion matrix for clustered labels trained via a naive Bayes classifier.

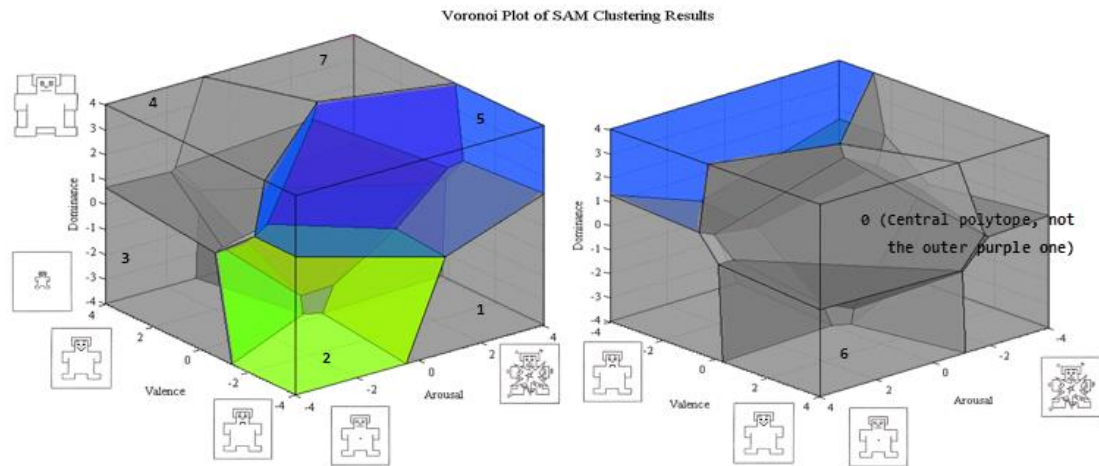

Figure 283: Clusters 5 (PPV = 54%) and 2 (PPV = 51%) highlighted for clarification of the naive Bayes classifier results.

In summary our classification accuracy, for the naive Bayes classifier, is 42.45% for grid based labels and 48.07% for cluster based labels.

The naive Bayes classifier does not appear to be a strong choice in the field of PPR, The studies that do employ it often only do so as a part of a comparison of classifiers. One of the strongest results for the naive Bayes classifier in PPR is Zhai & Barreto (J. Zhai & Barreto, 2008). This experiment used a stressful task in human computer interaction to stimulate strong (as opposed to our weekly induced emotions) stress emotions. Working with 32 participants and differentiating between 2 emotional states (stressed vs. not stressed) the naive Bayes classifier reported a 78.65% accuracy. However this was still the worst performing classifier for this study which also showed 88.02% for a Decision Tree classifier and 90.10% for a SVM.

11.4 The Random Forest Classifier

In this section the random forest classifier can be tuned for the number of trees, and the allowed tree depth. As discussed in 2.4.7 the random forest classifier does not typically use a maximum depth, and our work in restricting the maximum depth is aimed more at gauging the complexity of the classification task. The tuning was achieved by taking a subset of 12 participants (to improve computational speed) and training multiple classifiers for each of these participants. The classifiers were trained on every combination of 11 different values for the number of trees present and 7 different values for depth (77 trials per participant). The results of these experiments are plotted in Figure 284 to Figure 286. From the graphs we infer that, for random forest classifiers, approximately 40 trees at a depth of 15 provided a point at which the classifier was optimal and any extra complexity was needless.

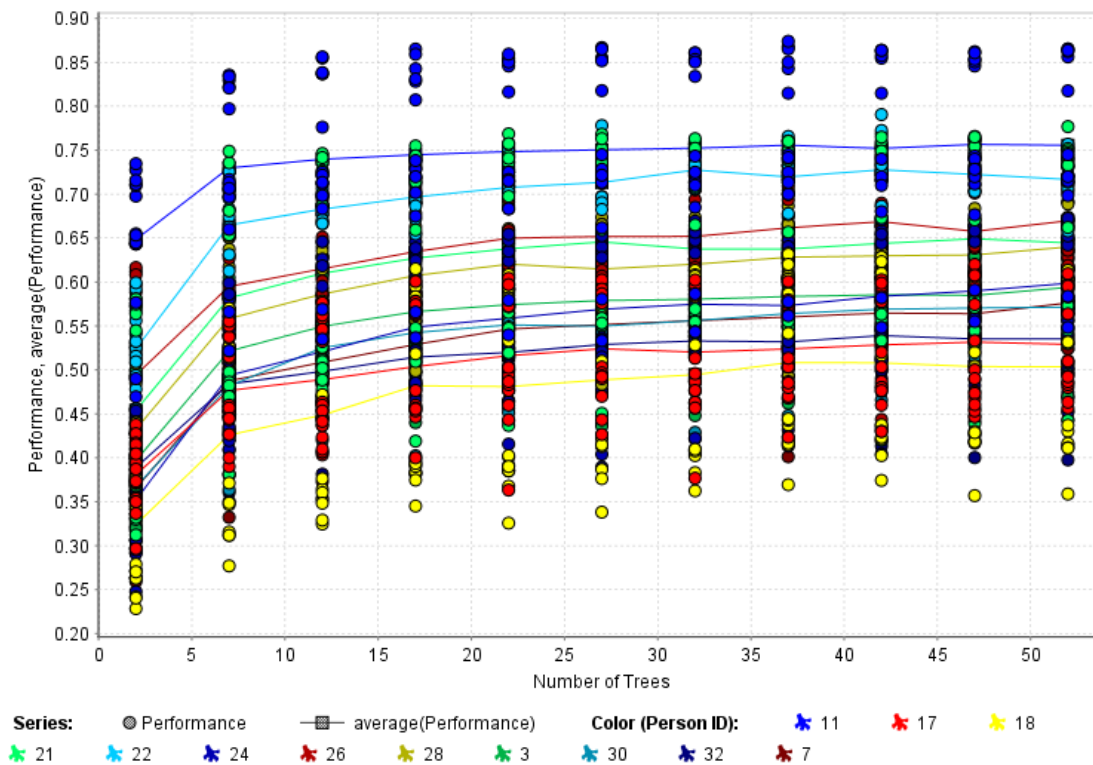

Figure 284: Random forest tuning for 12 participants. Shows results organised by the number of trees. Colour information is used to separate the participants. The number of trees used was 2, 7, 12, 17, 22, 27, 32, 37, 42, 47 & 52. A “scatter” effect was applied over the points to allow easier visualisation, the nature of the scatter may change from graph to graph.

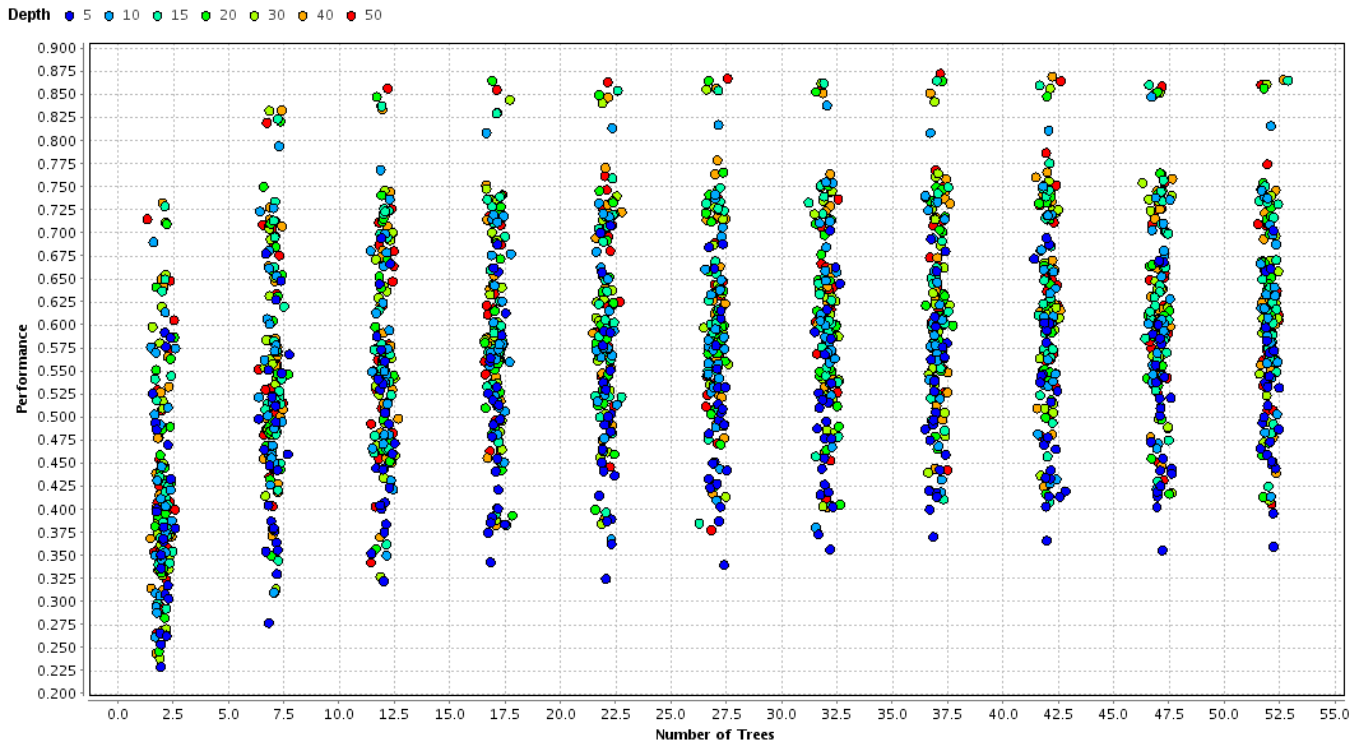

Figure 285: Random forest tuning for 12 participants. Shows results organised by the number of trees. Colour information is used to show tree depth.

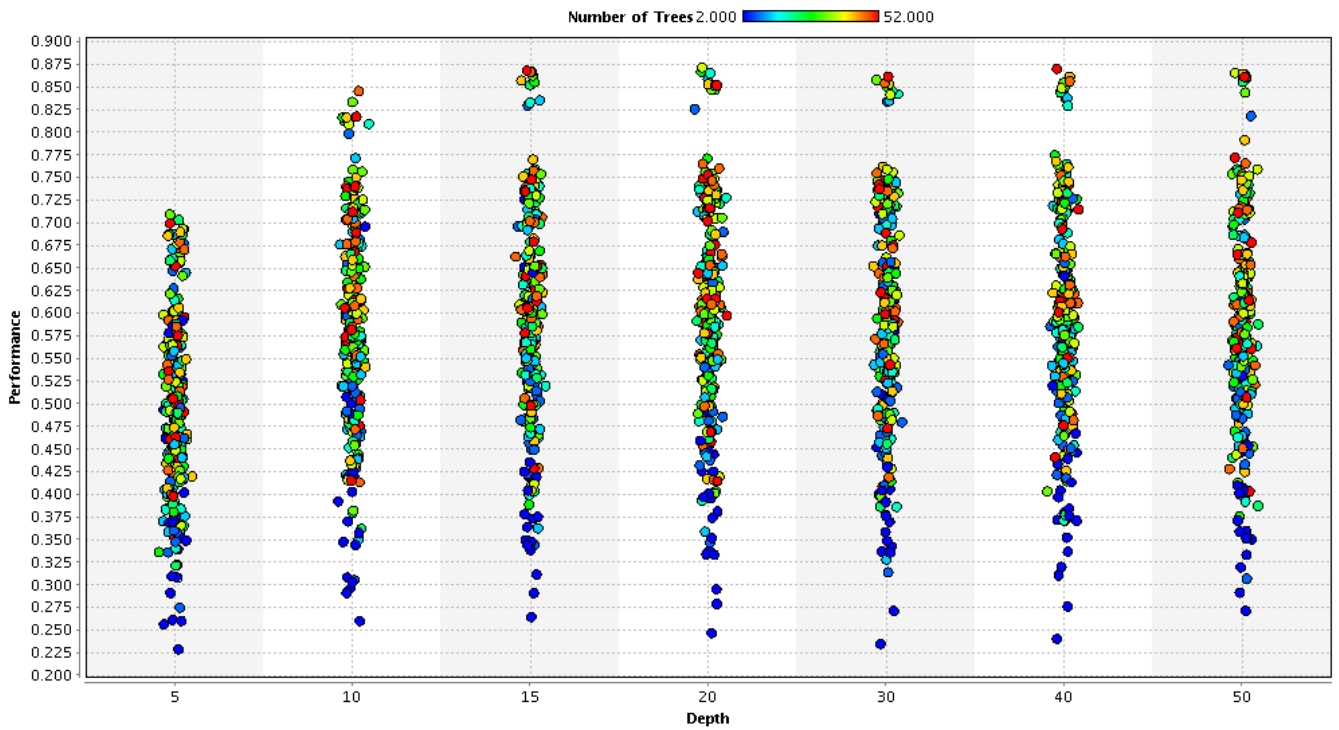

Figure 286: Random forest tuning for 12 participants. Shows results organised by the depth of the trees. Colour information is used to separate the number of trees.

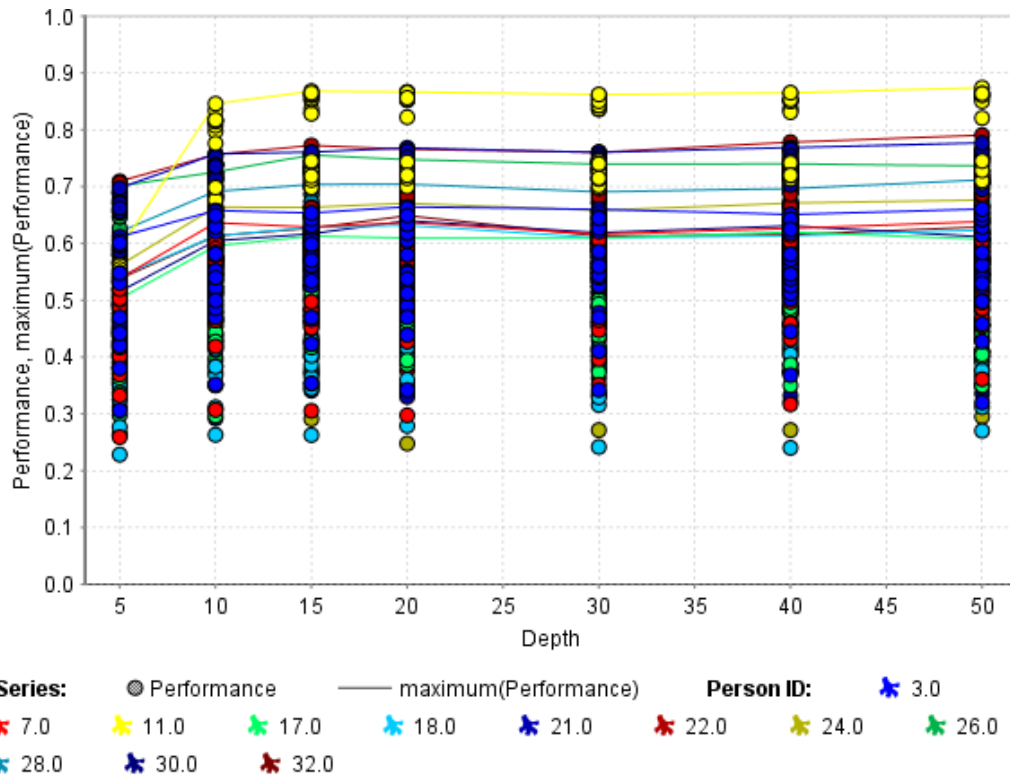

Figure 287: Random forest tuning for 12 participants. Shows results organised by the depth of the trees. Colour information is used to separate the participants, lines show the maximum performance for each participant at the given depth.

The success of the training varied greatly by participant, but average performance was around 60%, with some participants being classified at close to 90%. In general our cluster based labels were most likely to achieve very good classification rates (above 80%). A comparison of result distributions is shown in Figure 288. Overall both labelling systems appear to be useful.

Histograms of Performance for All Participants (RF)

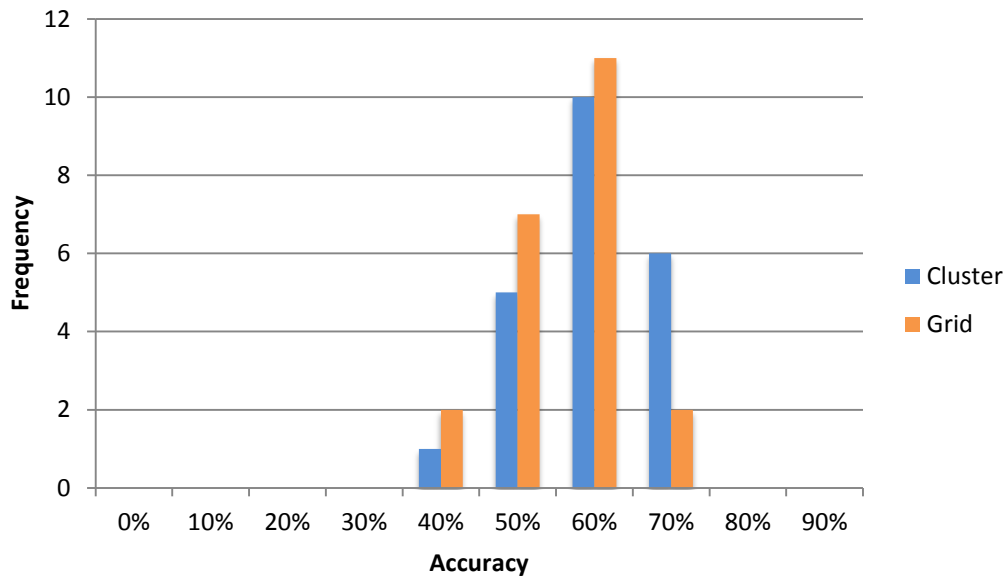

Figure 288: Histograms of performance of random forest classifiers for all participants. Histograms for cluster and grid labels are shown, each using 10% bins.

Our best classification results were obtained when a participant did not experience all the available emotional states, as discriminating between fewer states is an easier task. We typically saw results in the range of 70-80% accuracy for 6 states as compared to 60-70% accuracy for 8 or 9 states.

We have compiled all participants' results into a set of two confusion matrices (one for each label type) which are presented in Figure 289 and Figure 290.

		PREDICTION														
		SAM9_1	SAM9_2	SAM9_3	SAM9_4	SAM9_5	SAM9_6	SAM9_7	SAM9_8	SAM9_9	α	β	TP	FN	FP	TN
ACTUAL	SAM9_1	877	58	54	115	80	14	98	69	59	4%	38%	877	547	445	11582
	SAM9_2	57	1181	86	157	119	31	122	96	60	6%	38%	1181	728	646	10896
	SAM9_3	54	58	684	49	57	17	107	54	52	4%	40%	684	448	479	11840
	SAM9_4	83	126	42	986	127	29	126	102	49	7%	41%	986	684	844	10937
	SAM9_5	65	117	64	181	1049	23	114	141	96	7%	43%	1049	801	798	10803
	SAM9_6	10	38	27	51	31	520	23	27	29	2%	31%	520	236	196	12499
	SAM9_7	75	109	71	114	131	22	1016	105	71	7%	41%	1016	698	801	10936
	SAM9_8	54	94	60	114	139	32	120	1008	87	6%	41%	1008	700	674	11069
	SAM9_9	47	46	75	63	114	28	91	80	744	4%	42%	744	544	503	11660
PPV		66%	65%	59%	54%	57%	73%	56%	60%	60%						
NPV		95%	94%	96%	94%	93%	98%	94%	94%	96%	Accuracy = 59.96%					

Key

Correct	Very Similar	Relevant	Unrelated	Oposing
---------	--------------	----------	-----------	---------

TP = True Positives, FN = False Negatives, FP = False Positives, TN = True Negatives
 PPV = Positive Predictive Value, NPV = Negative Predictive Value,
 α = False Positive Rate, β = False Negative Rate

Figure 289: Summary confusion matrix for grid based labels trained via a random forest classifier. As not all predictions are equally wrong the matrix is displayed in a colour coded manner to indicate the nature of each error. The rightmost column provides summary statistics for each label in terms of True Positives, False Positives, False Negatives and True Negatives. The last row gives individual and total classification accuracies. The coloured areas are akin to a bar graph which shows that cells portion of the total predictions for the associated label. The colour represents new nature of the guess, blue for correct, two greens for level of similarity, pink for an unrelated state and red for an opposing state.

		PREDICTION													
		CLUST0	CLUST1	CLUST2	CLUST3	CLUST4	CLUST5	CLUST6	CLUST7	α	β	TP	FN	FP	TN
ACTUAL	CLUST0	1093	118	130	98	111	82	54	111	8%	39%	1093	704	837	9834
	CLUST1	111	945	95	84	91	33	80	47	5%	36%	945	541	575	10407
	CLUST2	173	91	1167	82	117	50	62	78	6%	36%	1167	653	617	10031
	CLUST3	88	60	77	761	54	66	28	37	4%	35%	761	410	459	10838
	CLUST4	147	94	119	43	1035	68	53	117	6%	38%	1035	641	614	10178
	CLUST5	93	49	59	76	54	990	50	68	4%	31%	990	449	418	10611
	CLUST6	79	100	61	31	57	68	940	59	4%	33%	940	455	398	10675
	CLUST7	146	63	76	45	130	51	71	1102	5%	35%	1102	582	517	10267
PPV		57%	62%	65%	62%	63%	70%	70%	68%						
NPV		93%	95%	94%	96%	94%	96%	96%	95%	Accuracy = 64.43%					

Key

Correct	Very Similar	Relevant	Unrelated	Oposing
---------	--------------	----------	-----------	---------

TP = True Positives, FN = False Negatives, FP = False Positives, TN = True Negatives
 PPV = Positive Predictive Value, NPV = Negative Predictive Value,
 α = False Positive Rate, β = False Negative Rate

Figure 290: Summary confusion matrix for clustered labels trained via a random forest classifier.

In summary, our classification accuracy is 59.96% for grid based labels and 64.43% for cluster based labels. The classifier for the grid based classification scheme had adequate results in predicting an emotion (PPV = 54% to 73%) but is an excellent tool for establishing if someone is not in a given emotion (NPV = 93% to 98%, α = 2% to 8%). The state of being in neutral Valence with high Arousal stands out as being

the easiest to predict (PPV = 73%). Interestingly, the mistakes made by the classifier seem to favour predicting similar emotional states to the correct value.

The classifier for the cluster based classification scheme had adequate results in predicting an emotion (PPV = 57% to 70%) and, like the grid labels, is also an excellent tool for establishing if someone is not in a given emotion (NPV = 93% to 96%, α = 4% to 8%). The clusters 5, 6 and 7 stand out as being the easiest to predict (PPV = 68% to 70%).

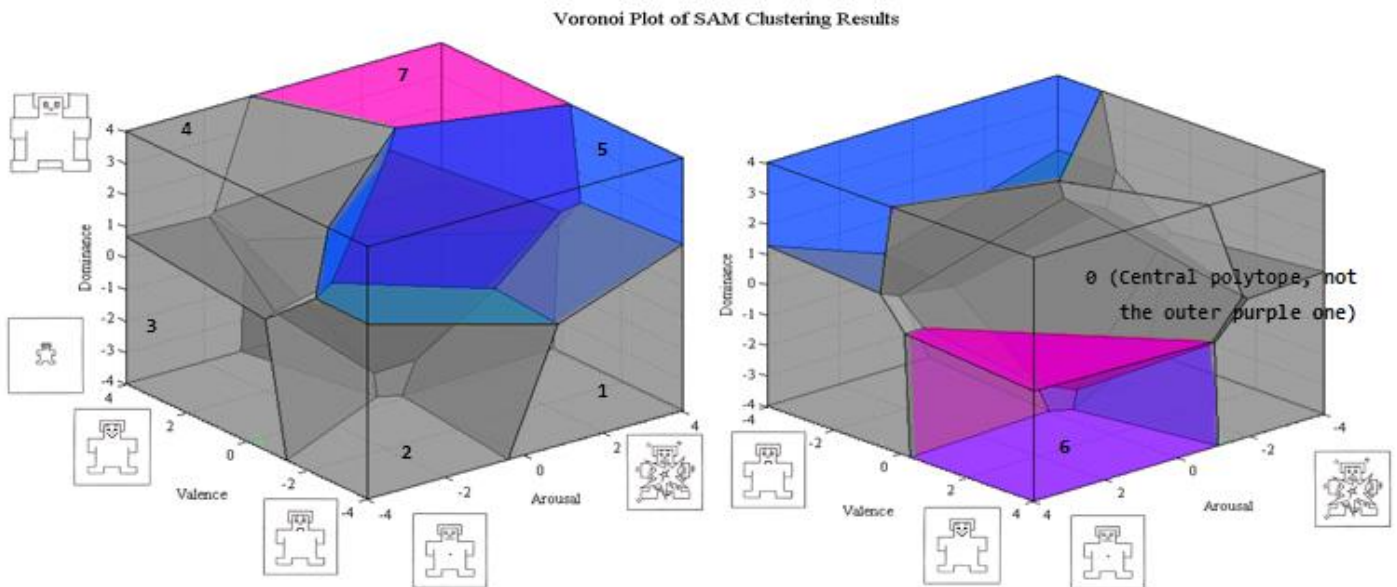

Figure 291: Clusters 5 (PPV = 70%), 6 (PPV = 70%) & 7 (PPV = 68%) highlighted for clarification of random forest results.

11.5 The Neural Network Classifier

For the Artificial Neural Network (ANN) architecture we employ a feed-forward neural network trained by a back-propagation algorithm to create what is known as a Multi-Layer Perceptron (MLP) model. The activation function we used a sigmoid function, given by $\phi(y_i) = (1 + e^{-v_i})^{-1}$; where y_i is the output of the i 'th neuron and v_i is the weighted sum of the input synapses. The MLP model was chosen based on its known performance benefits and successful use in related works e.g. Haag et al., (2004); Wagner & Andre (2005); Yoo et al., (2005) & Yannakakis & Hallam (2008).

We tune the ANN to discover its optimal architecture in two rounds. The first is a basic investigation to discover the “ballpark” values for the parameters which have the greatest impact on the ANN architecture and performance. The second is as a fine tuning exercise.

11.5.1. Basic Tuning of the ANN Classifier, Number of Layers and Training Epochs

We would like to establish how the ANN will generally be created in terms of the amount of layers and roughly how many training cycles are required. To this end we ran a sequence of experiments over our 12 “tuning” subjects in which an ANN was trained for 500, 1000, 1500 ... 5000 cycles. Each of these experiments was repeated for one to three hidden layers. Each hidden layer was of size $0.5n$, $1n$, $1.5n$, $2n$ where n is the number of inputs. The resulting data gave us some ball park information on how we should be configuring our networks before attending to matters of finer tuning.

An initial analysis of the data (see Figure 292) showed that the generalised ANN structure was dependent on the label systems we used. The grid labels preferred a network with two hidden layers while the cluster labels preferred one hidden layer. Both labelling systems preferred a layer size of $1.5n$ when at the previously mentioned optimal number of hidden layers (see Figure 293). We plotted the effects of the training cycles for the respective optimal number of layers, see Figure 293.

Using this graph we estimated that a good value for the number of training cycles would be 3,500 in both cases.

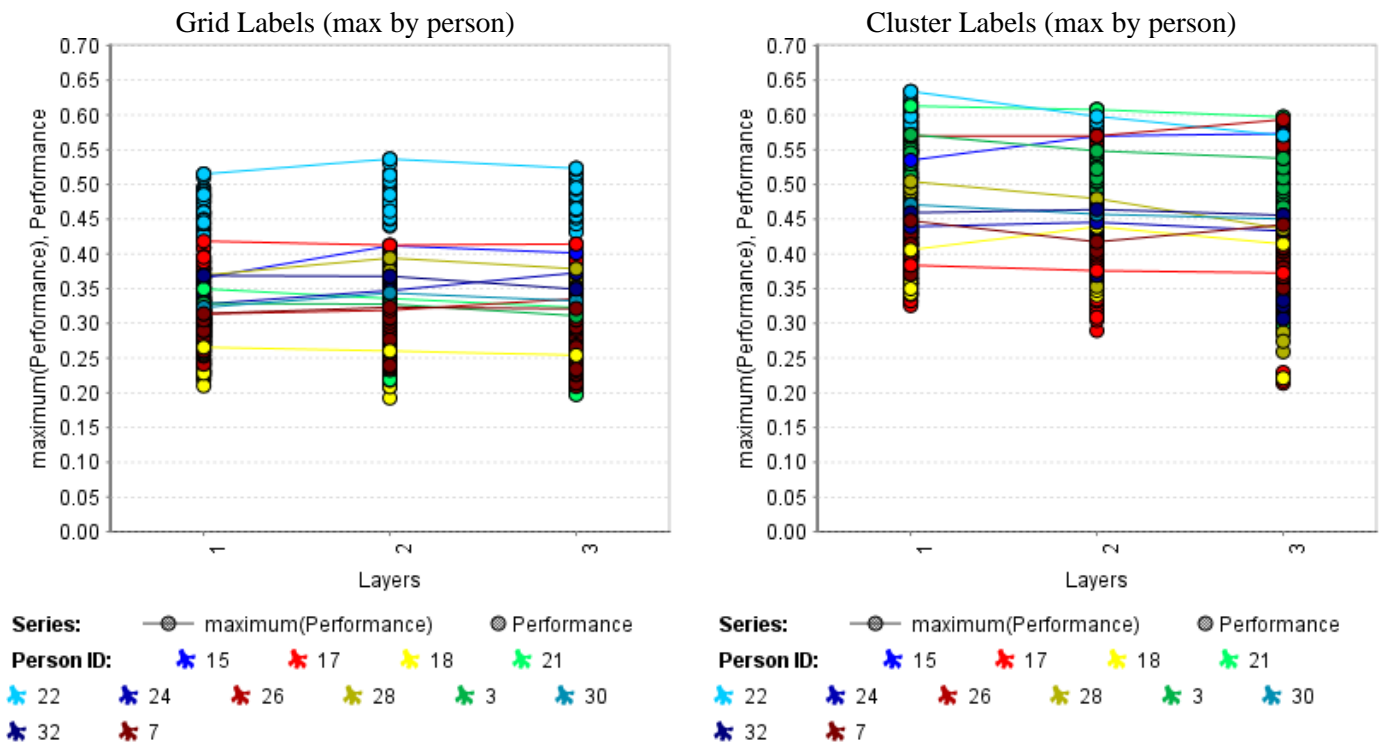

Figure 292: ANN performance tuning. Results shown by number of layers and coloured by person.

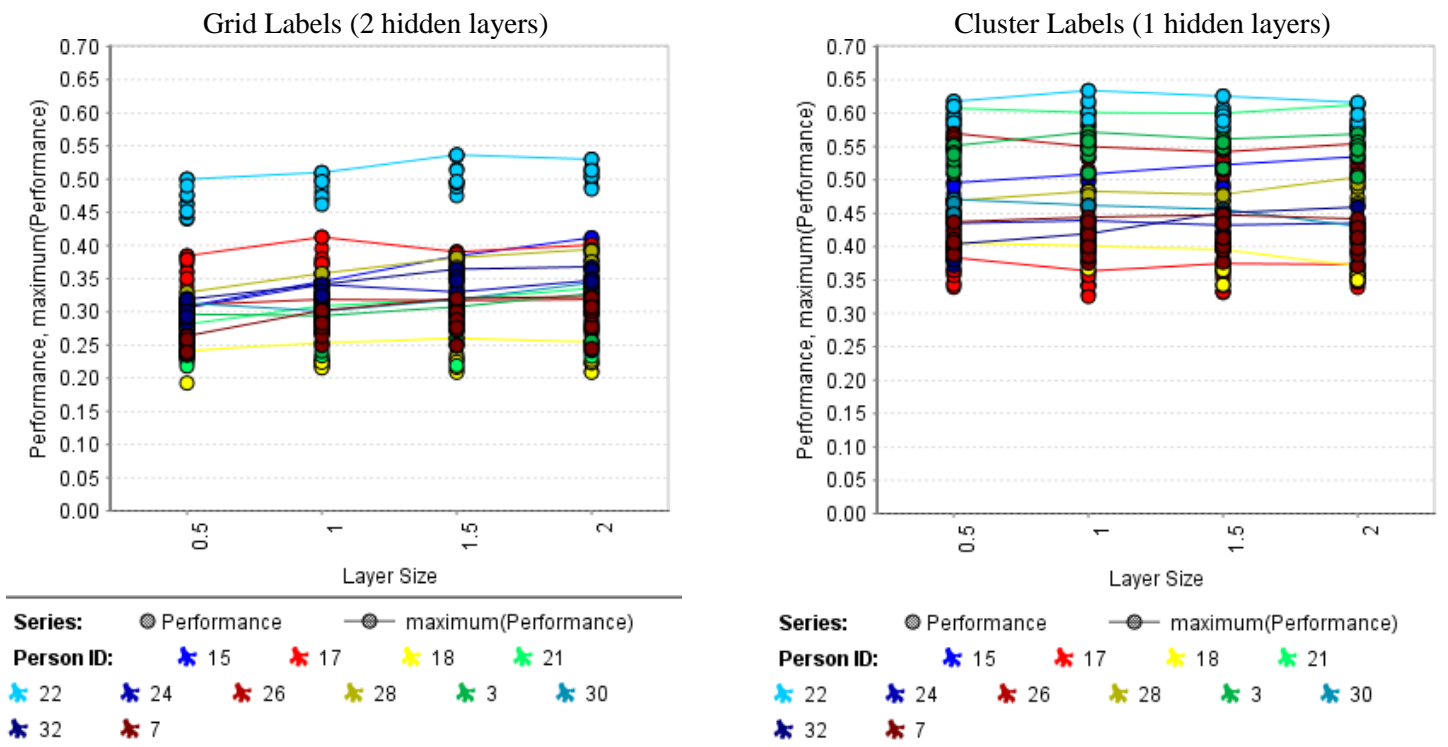

Figure 293: ANN performance tuning. Results shown by layer size (x number of inputs) and coloured by person.

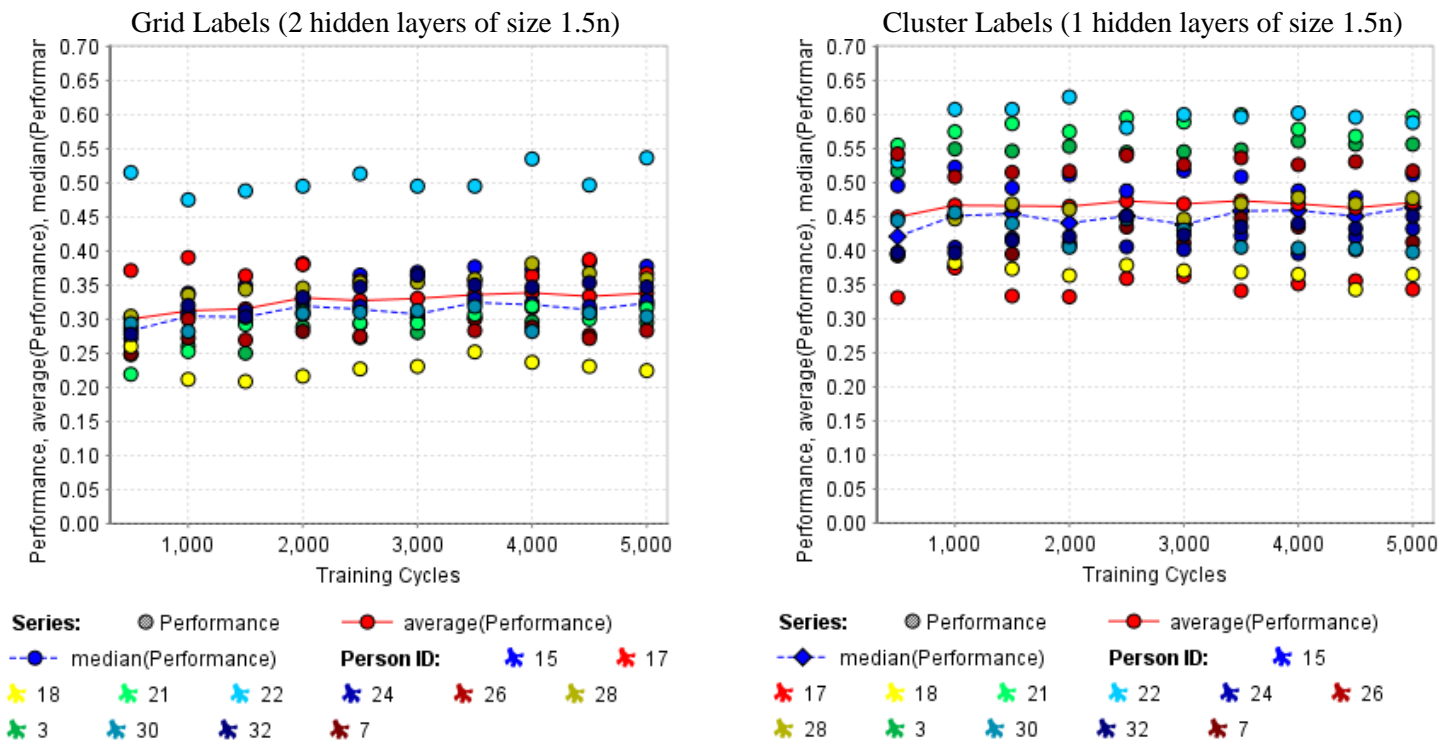

Figure 294: ANN Performance tuning. Results shown by number of training cycles and coloured by person.

Based on these results, we chose generic ANN parameters as per Table 21. Given that our selected parameters will not be optimal for all participants, we examined the performance loss for each participant in the tuning set. This was achieved by subtracting the performance of the selected parameters from the performance of the best parameter set for that person. The results of this (see Table 22) show that, on average, the grid labels lost 3.79% prediction accuracy, while the cluster labels lost 6.1% prediction accuracy. The loss of accuracy for cluster labels was over 10% in two cases, which is significant.

Table 21: ANN parameters

Parameter	Grid	Cluster
Number of Hidden Layers	2	1
Layer Size	1.5n	1.5n
Training Cycles	3500	3500

Table 22: ANN performance comparison, showing the performance loss (last group of three columns) for each participant in the tuning set. Values were calculated by subtracting the performance of the selected parameters (as per Table 21) from the performance of the best parameter set for that person (second group of four columns).

Label	Person ID	Layers	Layer Size	Training Cycles	Best Performance	Selected Performance	Diff
Cluster	3	1	1	3000	57.18%	53.08%	4.10%
Cluster	7	1	1.5	3500	44.77%	38.81%	5.96%
Cluster	15	3	2	3500	57.30%	45.75%	11.55%
Cluster	17	1	0.5	2000	38.38%	31.32%	7.05%
Cluster	18	2	0.5	4000	43.91%	41.69%	2.22%
Cluster	21	1	2	5000	61.29%	55.51%	5.78%
Cluster	22	1	1	5000	63.39%	54.49%	8.91%
Cluster	24	2	1.5	2000	44.54%	42.51%	2.03%
Cluster	26	3	0.5	5000	59.34%	55.80%	3.54%
Cluster	28	1	2	4000	50.41%	38.12%	12.29%
Cluster	30	1	0.5	500	47.10%	44.45%	2.65%
Cluster	32	2	2	3000	46.40%	39.31%	7.09%
Grid	3	1	1	1000	32.88%	27.61%	5.27%
Grid	7	2	2	1500	32.30%	30.66%	1.64%
Grid	15	2	2	4500	41.17%	37.83%	3.34%
Grid	17	1	1.5	2500	41.84%	37.74%	4.10%
Grid	18	1	0.5	1500	26.55%	21.02%	5.53%
Grid	21	1	2	5000	34.95%	31.39%	3.56%
Grid	22	2	1.5	5000	53.67%	51.67%	2.00%
Grid	24	3	2	5000	37.28%	31.36%	5.92%
Grid	26	3	1.5	500	33.55%	27.32%	6.23%
Grid	28	2	2	3500	39.41%	35.60%	3.81%
Grid	30	2	2	5000	34.37%	32.91%	1.47%
Grid	32	1	1	2000	36.88%	34.28%	2.60%
Averages							
Grid					37.07%	33.28%	3.79%
Cluster					51.17%	45.07%	6.10%
Both					44.12%	39.18%	4.94%

11.5.2. Further Tuning of the ANN, Momentum and Learning Rate

Until now the learning rate and momentum used to train the ANN classifiers was left at the generally optimal defaults as specified by the authors of the ANN implementation in use (Mierswa & Wurst, 2006). To determine if any variation on these settings is beneficial, we tested for five different values of each parameter (0.1 to 0.5). The results of this tuning, shown in Figure 295, displayed no visually apparent trend.

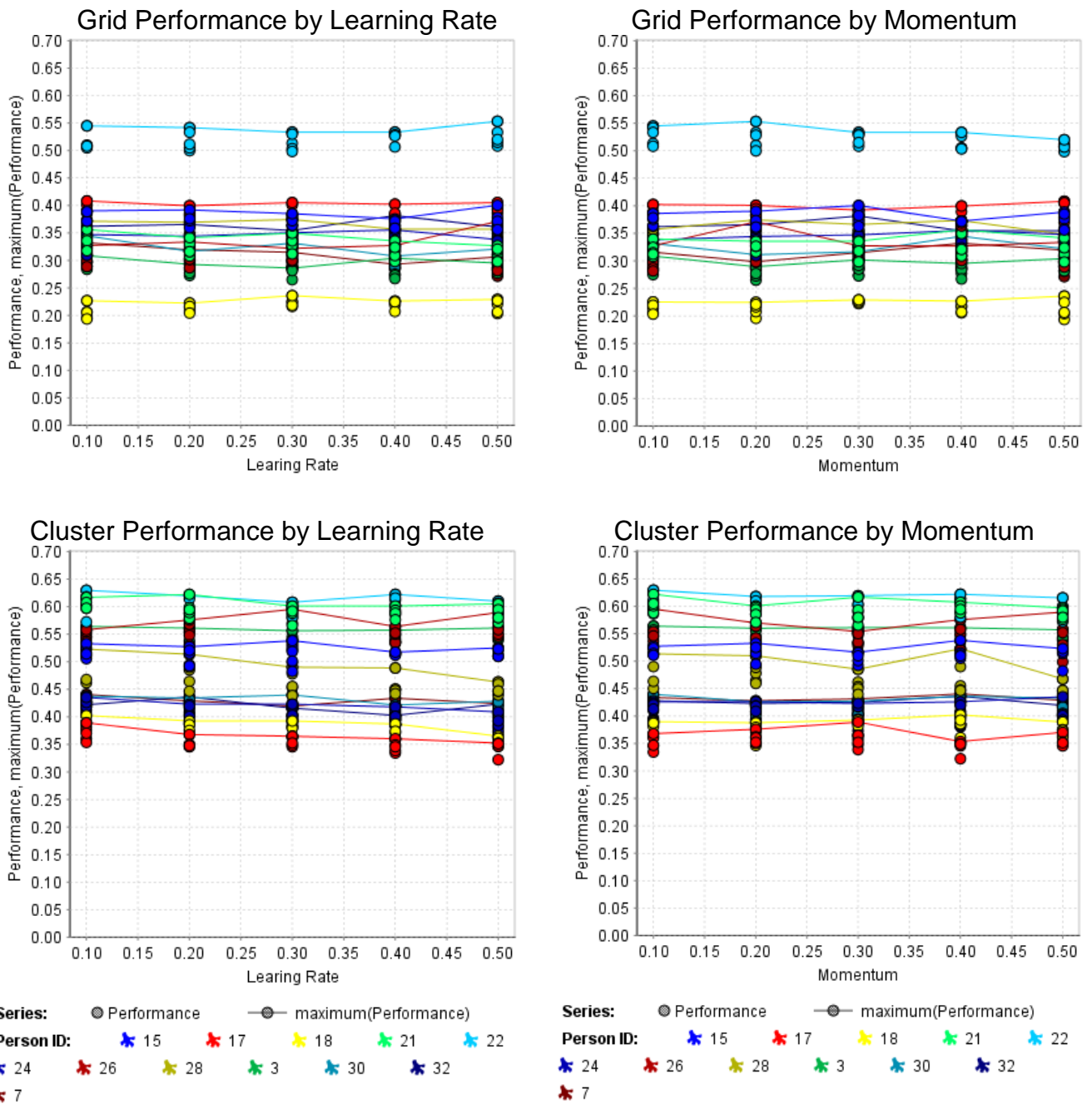

Figure 295: Fine tuning for grid and cluster labels shows no apparent visual trend.

The fine tuning has around a 5% performance change according to the parameters chosen in both label systems. To choose appropriate values we computed three metrics to evaluate the performance of each parameter combination across the set of tuning participants and compared the results (see Table 23). The metrics were:

- Average performance loss:
 - Average difference in prediction accuracy between a participant's best recorded performance and the performance for the given parameters.
- Top 1%:
 - Number of participants where the performance loss was < 1%.
- Worst 1%:
 - Number of participants where the performance loss was < 1% above the worst recorded performance loss.

Table 23: Fine tuning of the ANN classifier.

Momentum	Learning Rate	Grid			Cluster		
		Average	# top 1%	# worst 1%	Average	# top 1%	# worst 1%
0.1	0.1	2.53%	2	1	1.55%	4	0
0.2	0.1	3.23%	1	2	1.67%	2	0
0.3	0.1	2.97%	2	1	2.10%	3	0
0.4	0.1	2.00%	4	1	1.72%	6	0
0.5	0.1	3.09%	1	3	2.27%	3	1
0.1	0.2	3.54%	0	4	1.57%	4	0
0.2	0.2	3.26%	1	2	2.83%	1	0
0.3	0.2	2.46%	2	1	3.01%	2	2
0.4	0.2	3.90%	1	4	1.85%	3	0
0.5	0.2	2.86%	0	0	3.69%	0	1
0.1	0.3	2.82%	1	1	2.43%	2	2
0.2	0.3	3.21%	1	2	2.82%	1	1
0.3	0.3	3.14%	0	0	4.00%	0	2
0.4	0.3	2.90%	3	3	3.58%	2	2
0.5	0.3	3.16%	3	2	4.26%	0	3
0.1	0.4	3.14%	1	1	3.29%	2	1
0.2	0.4	3.28%	0	3	2.85%	0	0
0.3	0.4	2.75%	4	2	4.29%	0	1
0.4	0.4	3.64%	1	2	3.85%	1	3
0.5	0.4	3.51%	1	3	3.55%	0	1
0.1	0.5	3.21%	0	3	3.37%	0	1
0.2	0.5	2.65%	2	2	3.23%	0	2
0.3	0.5	3.05%	2	1	3.64%	1	2
0.4	0.5	3.28%	1	1	4.49%	0	5
0.5	0.5	3.98%	1	4	3.33%	1	1

Balancing these metrics showed that Grid and Cluster labels would perform best when:

- Grid Labels used a learning rate of 0.4 and a momentum of 0.1;
- Cluster Labels used a learning rate of 0.1 and a momentum of 0.1.

Overall no generalised ANN structure is apparent; the selection we have made is the “least terrible” one.

11.5.3. ANN Performance Overview

The tuned parameters, as per Table 24, were used to train all subjects in our experiment. A histogram of the results is shown in Figure 296. The lack of good performance results at this stage further suggests that the chosen ANN parameters do not generalise well to the full set of participants.

Table 24: Tuned ANN parameters

Parameter	Grid	Cluster
Number of Hidden Layers	2	1
Layer Size	1.5n	1.5n
Training Cycles	3500	3500
Learning Rate	0.4	0.1
Momentum	0.1	0.1

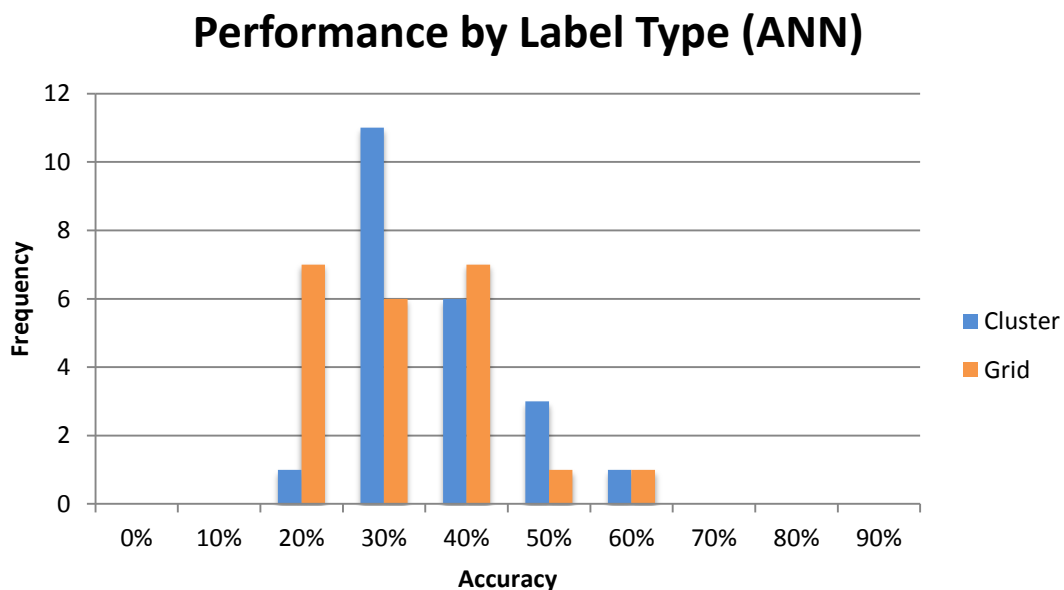

Figure 296: Histograms of performance of ANN for all participants. Histograms for cluster and grid labels are shown, each using 10% bins.

We have compiled all participants' results into a set of two confusion matrices (one for each label type) which are presented in Figure 289 and Figure 290.

		PREDICTION									α ,	β ,	TP,	FN,	FP,	TN
		SAM9_1	SAM9_2	SAM9_3	SAM9_4	SAM9_5	SAM9_6	SAM9_7	SAM9_8	SAM9_9						
ACTUAL	SAM9_1	373	120	79	144	143	45	154	155	95	8%	71%	373	935	949	11194
	SAM9_2	133	599	141	247	257	69	224	212	104	11%	70%	599	1387	1228	10237
	SAM9_3	76	147	294	86	93	48	151	104	100	7%	73%	294	805	869	11483
	SAM9_4	160	218	84	549	207	74	213	172	109	11%	69%	549	1237	1281	10384
	SAM9_5	163	215	132	257	515	75	219	203	154	12%	73%	515	1418	1332	10186
	SAM9_6	45	63	44	74	71	232	75	57	77	4%	69%	232	506	484	12229
	SAM9_7	142	211	171	208	216	66	480	178	125	11%	73%	480	1317	1337	10317
	SAM9_8	129	166	111	150	200	39	173	479	111	10%	69%	479	1079	1203	10690
	SAM9_9	101	88	107	115	145	68	128	122	372	7%	70%	372	874	875	11330
	PPV	28%	33%	25%	30%	28%	32%	26%	28%	30%						
NPV	92%	88%	93%	89%	88%	96%	89%	91%	93%	Accuracy = 28.94%						

Key

Correct	Very Similar	Relevant	Unrelated	Opposing
---------	--------------	----------	-----------	----------

TP = True Positives, FN = False Negatives, FP = False Positives, TN = True Negatives
 PPV = Positive Predictive Value, NPV = Negative Predictive Value,
 α = False Positive Rate, β = False Negative Rate

Figure 297: Summary confusion matrix for grid based labels Trained via an ANN. As not all predictions are equally wrong, the matrix is displayed in a colour coded manner to indicate the nature of each error. The rightmost column provides summary statistics for each label in terms of True Positives, False Positives, False Negatives and True Negatives. The last row gives individual and total classification accuracies. The coloured areas are akin to a bar graph which shows that cell's portion of the total predictions for the associated label. The colour represents new nature of the guess, blue for correct, two greens for level of similarity, pink for an unrelated state and red for an opposing state.

		PREDICTION								α ,	β ,	TP,	FN,	FP,	TN
		CLUST0	CLUST1	CLUST2	CLUST3	CLUST4	CLUST5	CLUST6	CLUST7						
ACTUAL	CLUST0	672	151	172	136	196	151	99	174	12%	62%	672	1079	1258	9459
	CLUST1	160	589	158	150	134	72	151	97	8%	61%	589	922	931	10026
	CLUST2	214	144	764	96	173	121	106	139	10%	57%	764	993	1020	9691
	CLUST3	124	101	113	423	92	121	77	83	7%	63%	423	711	797	10537
	CLUST4	221	198	191	89	637	153	107	198	9%	64%	637	1157	1012	9662
	CLUST5	180	81	122	138	136	591	137	134	7%	61%	591	928	817	10132
	CLUST6	147	132	121	91	99	115	532	112	7%	61%	532	817	806	10313
	CLUST7	212	124	143	97	182	84	129	682	9%	59%	682	971	937	9878
PPV	35%	39%	43%	35%	39%	42%	40%	42%							
NPV	90%	92%	91%	94%	89%	92%	93%	91%	Accuracy = 39.22%						

Key

Correct	Very Similar	Relevant	Unrelated	Opposing
---------	--------------	----------	-----------	----------

TP = True Positives, FN = False Negatives, FP = False Positives, TN = True Negatives
 PPV = Positive Predictive Value, NPV = Negative Predictive Value,
 α = False Positive Rate, β = False Negative Rate

Figure 298: Summary confusion matrix for clustered labels trained via an ANN.

In summary our classification accuracy is 28.94% for grid based labels and 39.22% for cluster based labels. The performance is lower than expected because ANN structure was very person dependant. While we could improve the results by allowing for person dependent tuning, this would not allow for proper comparison with other

classifiers that did generalise well. The classifier for the grid based classification scheme had adequate (better than chance) results in predicting an emotion (PPV = 25% to 32%) and is a useful tool for establishing if someone is not in a given emotion (NPV = 88% to 93%, α = 7% to 12%). States with a neutral Valence or Arousal generally performed better (PPV = 28% to 33%).

The classifier for the cluster based classification scheme had better results in predicting an emotion (PPV = 35% to 43%) and, like the grid labels, it is also a good tool for establishing if someone is not in a given emotion (NPV = 89% to 93%, α = 7% to 12%). Clusters 2, 7 and 8 stand out as being the easiest to predict (PPV = 43%, 42% and 42% respectively).

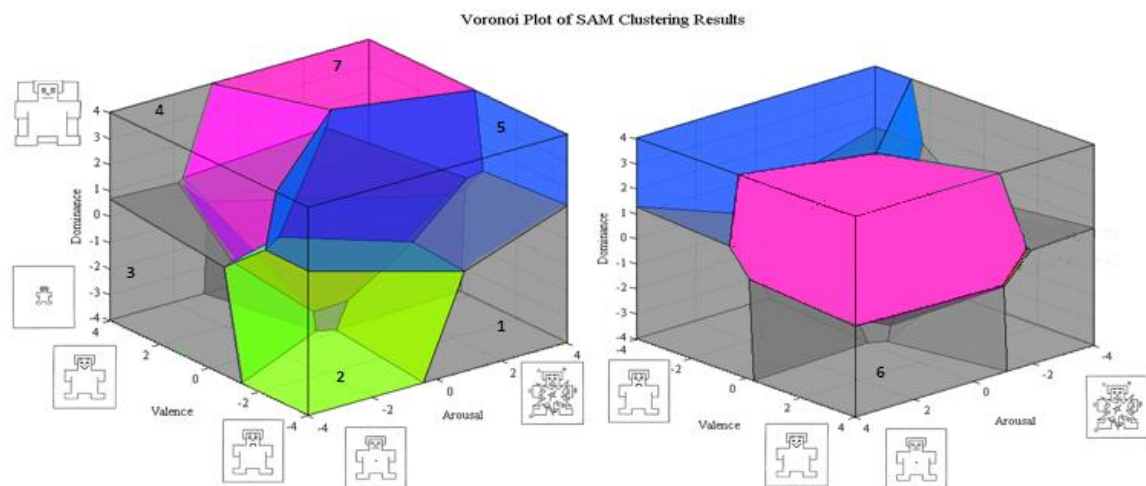

Figure 299: Clusters 2 (PPV = 43%), 5 (PPV = 42%) & 7 (PPV = 42%) Highlighted for clarification of ANN results.

11.6 k-NN Classifier

The k-NN classifier takes a sample point in the feature space and predicts its class by searching a set of known values for k nearest (known) samples. A vote is taken from the k -nearest samples to determine the classifier output. There are three classifier parameters we can adjust to tune the k-NN classifier:

- The value for k ;
- Whether the votes are weighted by their similarity to queried point;
- The measure used to determine how close (or similar) two points are.

k-NN classifiers can utilise various metrics to measure the closeness of the various feature space points. In this work we trialled several numerical distance metrics (discussed in more detail in chapter 2):

- Euclidean Distance;
- Canberra Distance;
- Chebychev Distance;
- Correlation Similarity;
- Cosine Similarity;
- Dice Similarity;
- Dynamic Time Warping Distance;
- Jaccard Similarity;
- Manhattan Distance;
- Max Product Similarity;
- Overlap Similarity.

The k-NN tuning investigation involved using values of k from 1 to 25, for every distance measure. Each of these experiments was run twice; with and without weighted voting enabled. The results of these runs are shown in Figure 300 and Figure 301 for grid and cluster labels respectively. Based on simple observation of these graphs we found Manhattan Distance to be the best metric for the grid based labels and Canberra Distance to be the best measure for the cluster based labels. Thus these two distance metrics are used classifiers 'measurement' parameter, leaving only k and the use of weighting to be resolved.

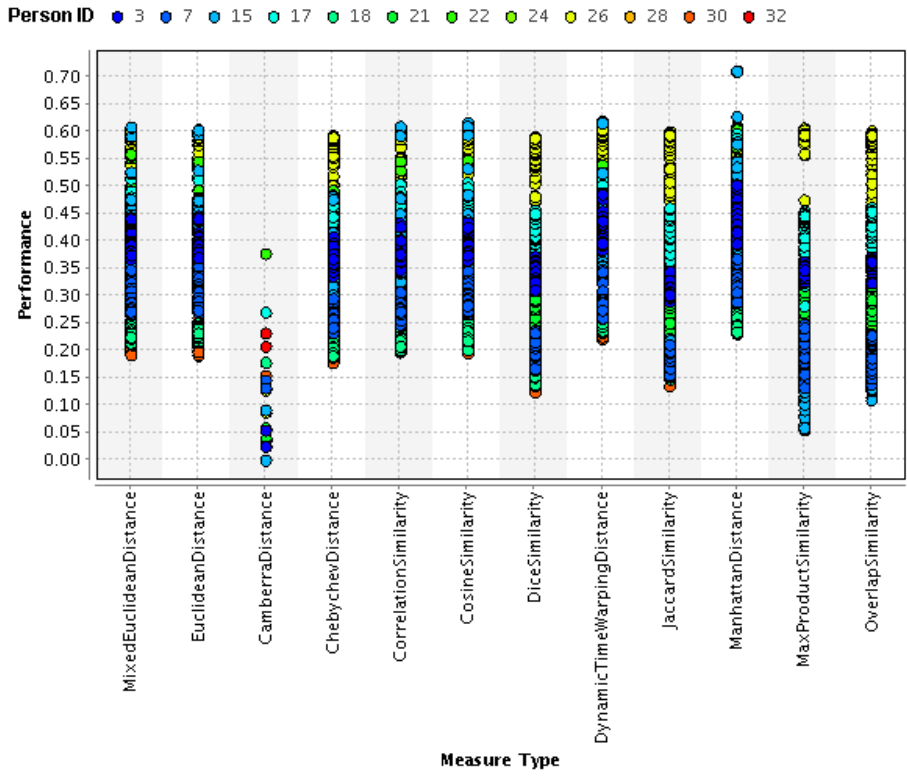

Figure 300: Plot of performance by distance measure, for grid labels. The Manhattan distance shows the best performance overall.

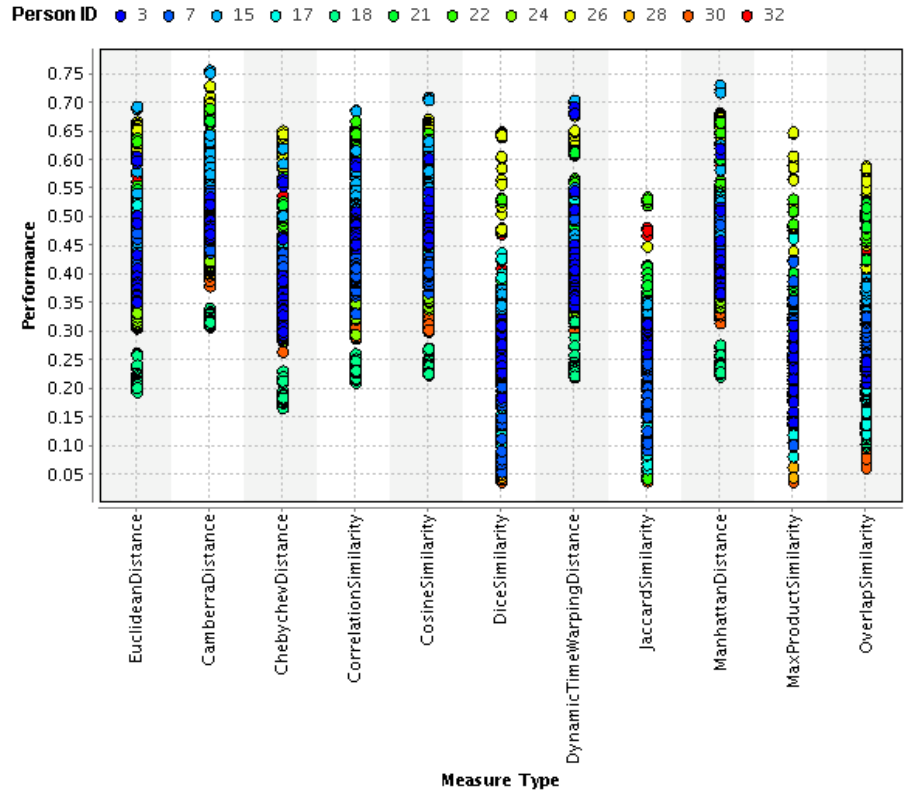

Figure 301: Plot of performance by distance measure, for grid labels. The Canberra distance shows the best performance overall.

Having established the best measures for each label type we now plot values for k for each of these cases in order to determine the optimal value for k , see Figure 302 and Figure 303. It is often the case that low values for k overfit the training data (Hastie, Tibshirani, & Friedman, 2009). These graphs show a sharp increase in the performance of both classifiers for values of k less than 4; which is most likely the result of such an over fitting. While different participants demonstrate various optimal values for k , we will use $k=4$ as an optimal value across participants.

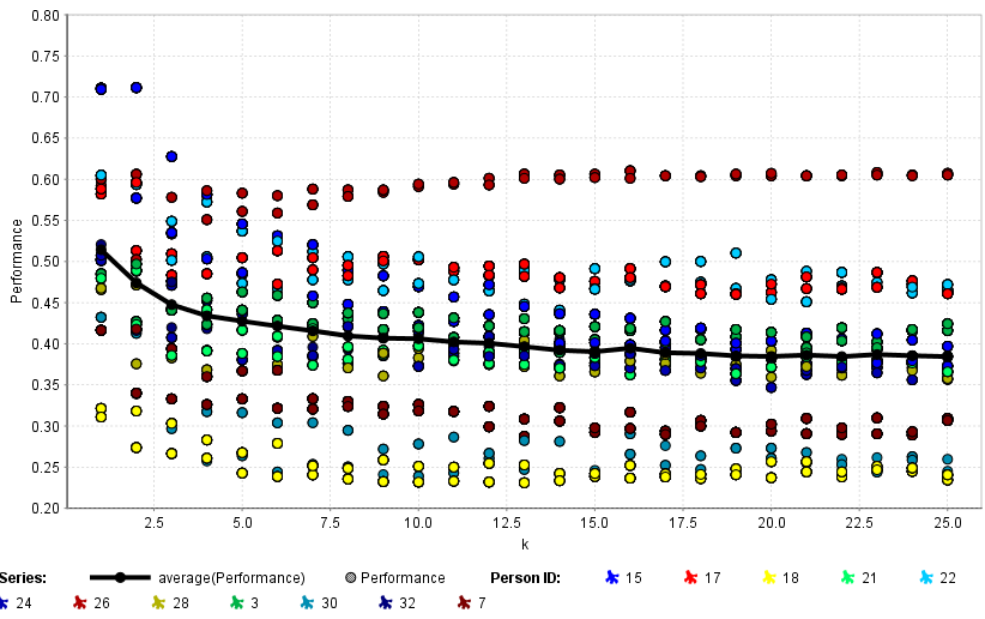

Figure 302: Grid, for Manhattan distance measure, comparing values of k . The black line is the average performance across all participants.

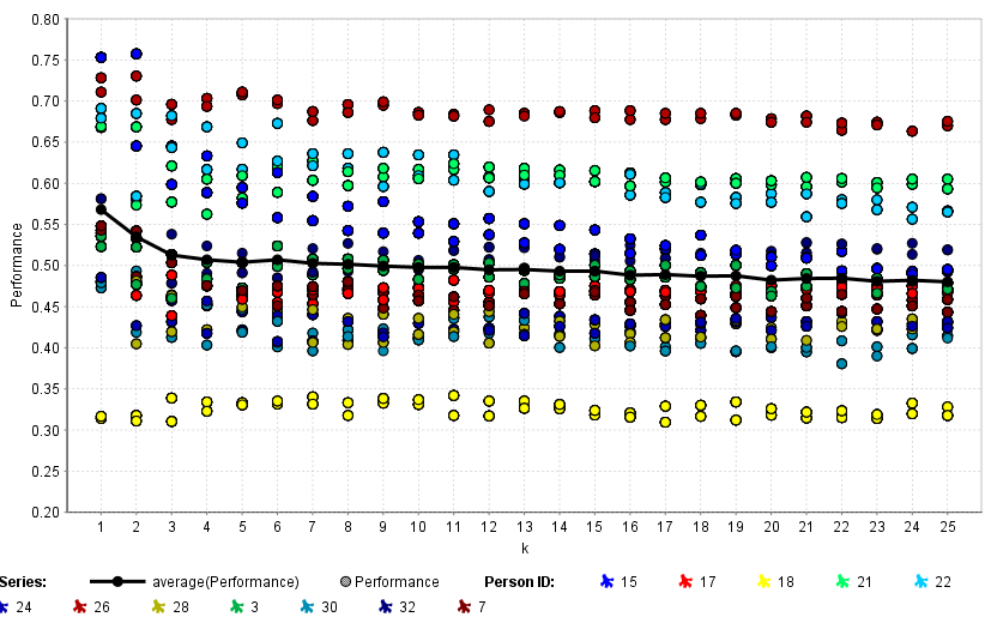

Figure 303: Cluster, for Canberra distance measure, comparing values of k . The black line is the average performance across all participants.

Having established both measure and k , we now investigate whether weighted voting is of use for the specified metrics at $k = 4$. We plotted performance for all cases with and without weighted voting and saw that in all cases weighted voting delivered an accuracy increase, generally between 2.5 to 5 percent.

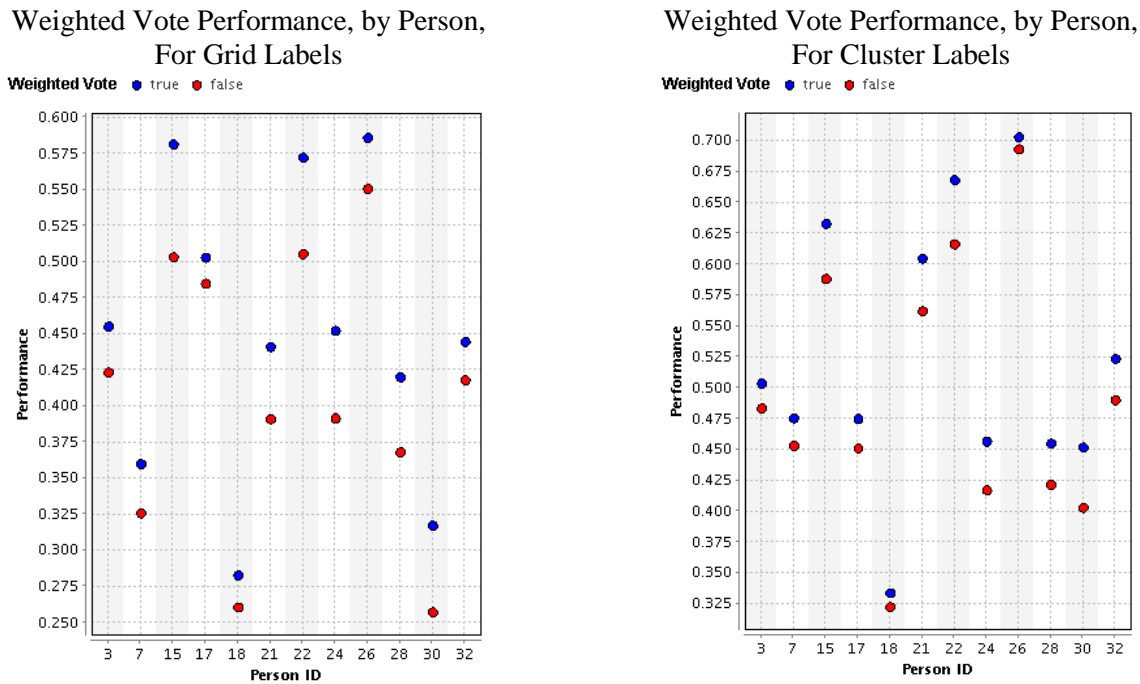

Figure 304: Comparison of weighted voting performance for grid and cluster labels at $k=4$.

To investigate the performance of the k -NN classifier on the entire population, we created two classifiers, configured according to our tuning results as follows:

1. For grid labels, Manhattan Distance, $k=4$, with weighted voting.
2. For cluster labels, Canberra Distance, $k=4$, with weighted voting.

The results of these experiments averaged around 46% for Grid based labels and 50% for Cluster based labels. This makes the naive k -NN classifier about 15% less accurate than the random forest classifier. However the k -NN classifier did perform well for two participants, as shown in Figure 305.

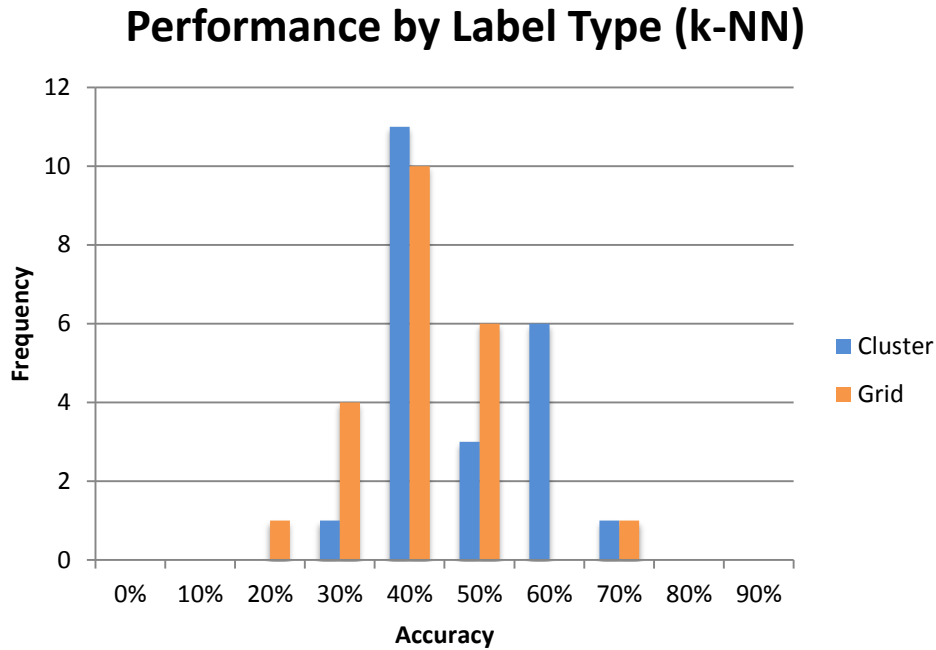

Figure 305: Performance of k-NN classifier.

Confusion matrices for both label schemes are shown in Figure 306 and Figure 307. The classifier for the grid based classification scheme had poor results in predicting an emotion (PPV = 34% to 53%) but is an excellent tool for establishing if someone is not in a given emotion (NPV = 89% to 98%, α = 2% to 10%). The states of being in neutral Valence with low or neutral Arousal; or being in positive Valence with high Arousal stand out as being the easiest to predict (PPV = 53%, 49% and 49% respectively). These results were significantly higher than chance guessing (11%).

The classifier for the cluster based classification scheme had improved results in predicting an emotion (PPV = 39% to 58%) and, like the grid labels, is also an excellent tool for establishing if someone is not in a given emotion (NPV = 86% to 96%, α = 5% to 12%). Cluster zero stands out as being the easiest to predict (PPV = 58%) and is shown in Figure 308.

		PREDICTION							α	β	TP	FN	FP	TN	
		CLUST0	CLUST1	CLUST2	CLUST3	CLUST4	CLUST5	CLUST6	CLUST7						
ACTUAL	CLUST0	3883	446	853	411	576	306	321	551	12%	47%	3883	3464	2866	20637
	CLUST1	408	1869	270	203	357	155	221	246	7%	50%	1869	1860	1904	25217
	CLUST2	665	266	2275	297	362	148	203	203	9%	49%	2275	2144	2421	24010
	CLUST3	343	152	312	1682	67	236	187	100	5%	45%	1682	1397	1488	26283
	CLUST4	500	381	435	120	2167	265	161	382	8%	51%	2167	2244	2112	24327
	CLUST5	250	156	116	218	228	1218	162	170	5%	52%	1218	1300	1410	26922
	CLUST6	238	220	221	148	144	153	900	141	5%	58%	900	1265	1385	27300
	CLUST7	462	283	214	91	378	147	130	1477	6%	54%	1477	1705	1793	25875
	PPV	58%	50%	48%	53%	51%	46%	39%	45%						
	NPV	86%	93%	92%	95%	92%	95%	96%	94%	Accuracy = 50.15%					

Key

Correct	Very Similar	Relevant	Unrelated	Opposing
---------	--------------	----------	-----------	----------

TP = True Positives, FN = False Negatives, FP = False Positives, TN = True Negatives
 PPV = Positive Predictive Value, NPV = Negative Predictive Value,
 α = False Positive Rate, β = False Negative Rate

Figure 306: Summary confusion matrix for clustered labels trained via a k-NN classifier.

		PREDICTION									α	β	TP	FN	FP	TN
		SAM9_1	SAM9_2	SAM9_3	SAM9_4	SAM9_5	SAM9_6	SAM9_7	SAM9_8	SAM9_9						
ACTUAL	SAM9_1	906	141	127	270	183	29	270	128	229	5%	60%	906	1377	1511	27790
	SAM9_2	141	1857	205	462	376	104	390	365	240	8%	55%	1857	2283	2218	25226
	SAM9_3	114	160	1008	120	207	58	271	109	188	5%	55%	1008	1227	1472	27877
	SAM9_4	321	480	141	2938	700	79	483	339	241	10%	49%	2938	2784	2628	23234
	SAM9_5	209	432	202	629	2463	77	385	450	227	10%	51%	2463	2611	2576	23934
	SAM9_6	22	94	53	86	76	298	40	50	53	2%	61%	298	474	576	30236
	SAM9_7	275	374	336	496	386	62	1906	318	204	9%	56%	1906	2451	2414	24813
	SAM9_8	165	321	157	297	400	59	305	1577	257	7%	55%	1577	1961	2041	26005
	SAM9_9	264	216	251	268	248	108	270	282	1556	6%	55%	1556	1907	1639	26482
	PPV	37%	46%	41%	53%	49%	34%	44%	44%	49%						
	NPV	95%	92%	96%	89%	90%	98%	91%	93%	93%	Accuracy = 45.94%					

Key

Correct	Very Similar	Relevant	Unrelated	Opposing
---------	--------------	----------	-----------	----------

TP = True Positives, FN = False Negatives, FP = False Positives, TN = True Negatives
 PPV = Positive Predictive Value, NPV = Negative Predictive Value,
 α = False Positive Rate, β = False Negative Rate

Figure 307: Summary confusion matrix for grid labels Trained via a k-NN classifier.

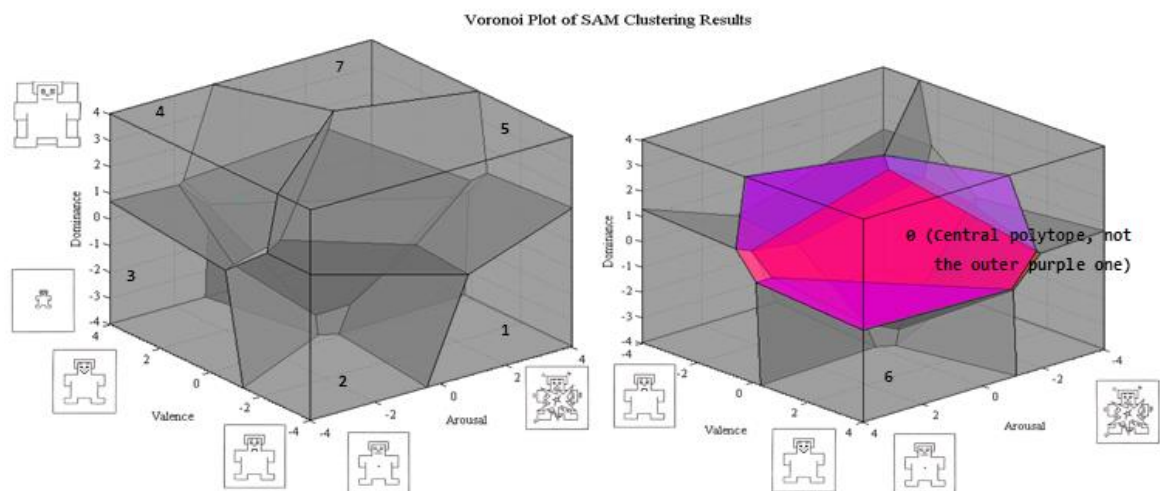

Figure 308: Clusters 5 (PPV = 54%) and 2 (PPV = 51%) highlighted for clarification of the naive Bayes classifier results.

11.7 Support Vector Machine Classifier

The Support Vector Machine (SVM) can be tuned for the up to three parameters in the kernel. This was achieved by taking a subset of 12 participants (to improve computational speed) and training multiple SVM classifiers for each of these participants.

The classifiers were trained using the recommendations of (Hsu et al., 2010). We examined four different kernels:

- Linear $K(x_i, x_j) = x_i^T \cdot x_j + c$
- Polynomial $K(x_i, x_j) = (\gamma \cdot x_i^T x_j + c)^d; \gamma > 0$
- Radial Basis Function (RBF) $K(x_i, x_j) = EXP(-\gamma ||x_i - x_j||^2); \gamma > 0$
- Sigmoid $K(x_i, x_j) = \tanh(\gamma \cdot x_i^T x_j + c)$

Where the values γ (gamma), c and d are kernel parameters which we will optimise.

The SVM implementation we used was *LibSVM* (Chang & Lin, 2011) and the tuning was performed separately for the 12 sample participants. We used an Evolutionary Algorithm (EA) to find appropriate values for γ and c and d where applicable, following a methodology prescribed by Frauke, & Christian 2005. In all cases the EA used a population of 20 and ran for 400 generations.

11.7.1. Linear Kernel

The Linear kernel is the simplest kernel function; it is composed of an inner product $x_i^T \cdot x_j$ plus an optional constant c . The LibSVM package we used was able to optimise c automatically, such that no tuning of the classifier was required. The cluster labelling system performed at 18% accuracy while the grid labels performed at 13% accuracy. These results are not much better than chance, showing that the linear kernel is not suitable for this task. Results of the training run are shown in Figure 309.

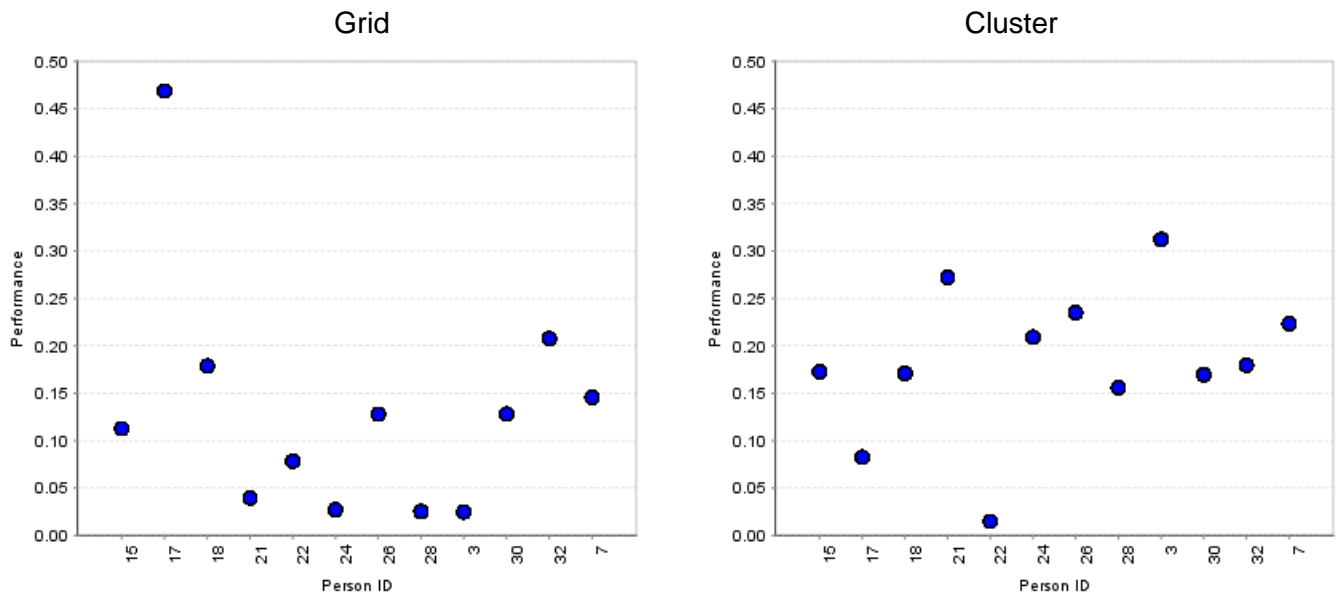

Figure 309: SVM, Linear kernel performance.

11.7.2. Polynomial Kernel

The Polynomial kernel is a non-stationary kernel which works best when the training data is normalised. It must be tuned for γ , the constant c and the polynomial degree d . In our work, on this problem, we found no noticeable effect on varying γ , c or d for the polynomial kernel. The cluster labelling system performed at 40% accuracy while the grid labels performed at 34% accuracy. Results of the training run are shown in Figure 310.

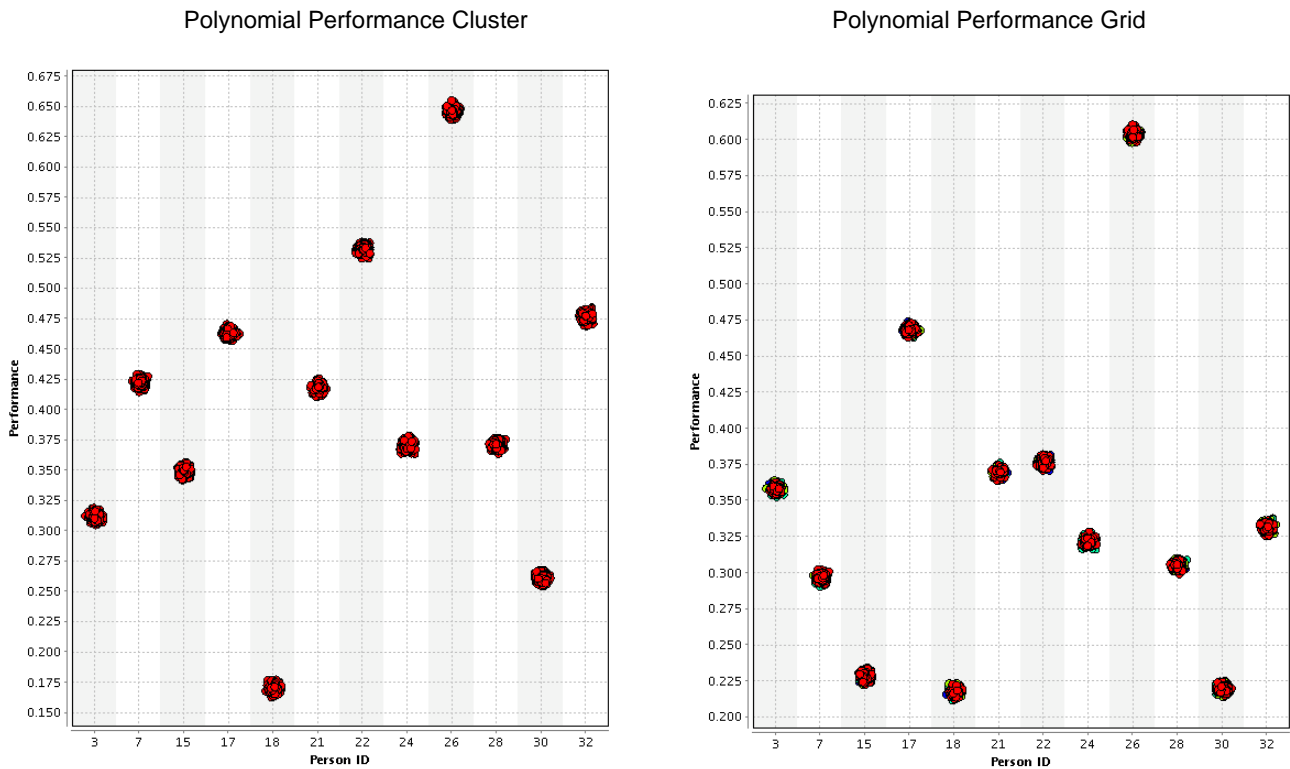
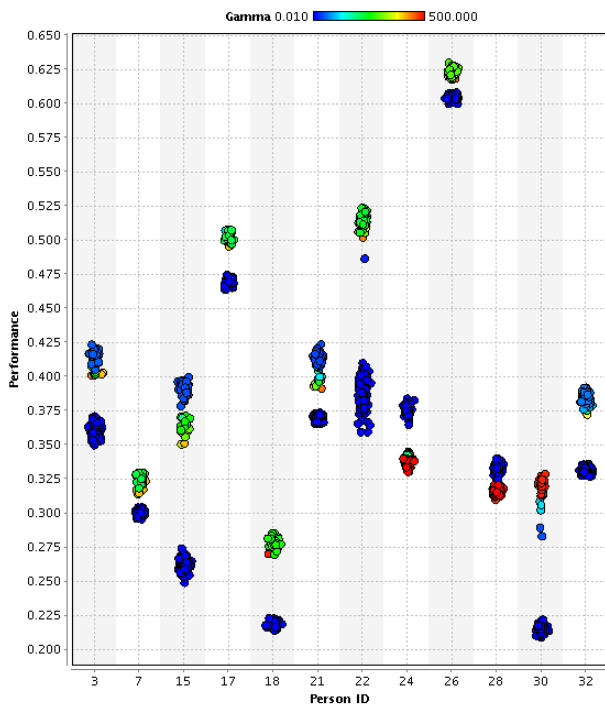

Figure 310: Polynomial kernel performance

11.7.3. Radial Basis Function (RBF) Kernel

The RBF is a popular method for creating a nonlinear SVM. Its usual kernel function is $K(x_i, x_j) = \text{EXP}(-\gamma ||x_i - x_j||^2)$; $\gamma > 0$; though some variants exist. A benefit of the RBF kernel is that we only need to optimise γ .

Grid Label Scheme: Performance by Person, Coloured by Gamma



Cluster Label Scheme: Performance by Person, Coloured by Gamma

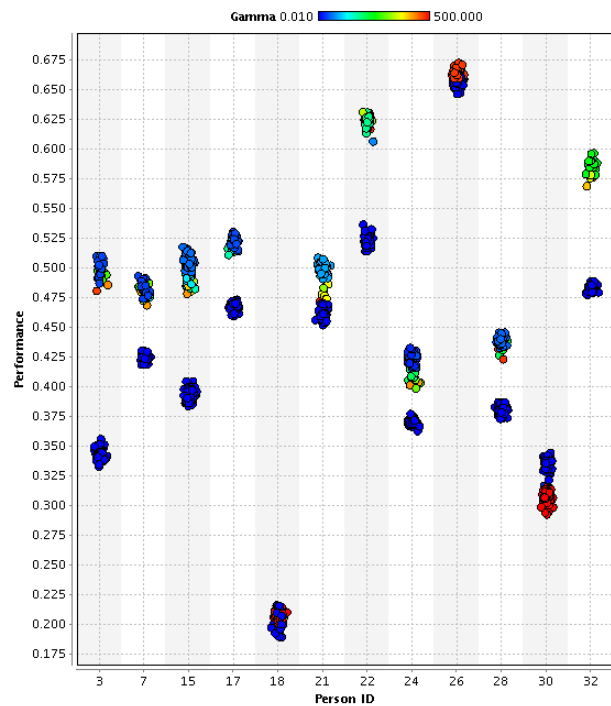
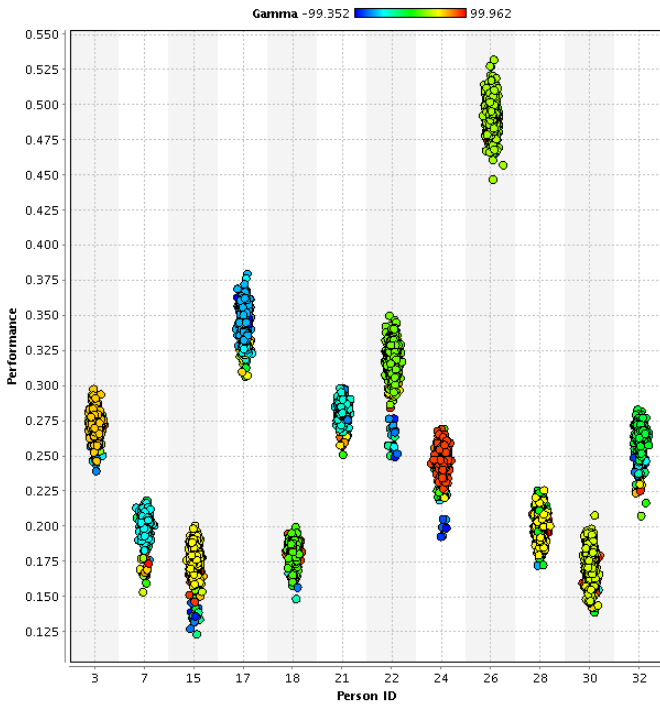

Figure 311: RBF kernel performance.

11.7.4. Sigmoid Kernel

The sigmoid kernel (H.-T. Lin & Lin, 2003) is also known as the *hyperbolic tangent kernel*. It uses the kernel function $K(x_i, x_j) = \tanh(\gamma \cdot x_i^T x_j + c)$ which provides two adjustable parameters, the slope γ and the intercept constant c . A common value for γ is $1/N$, where N is the data dimension. Our EA tuning averaged 40.24% performance accuracy for the cluster label scheme (see Figure 312) and 28.83% (see Figure 313) for the grid label scheme. The cluster approach to our labelling of the emotion state provided 11.41% more efficient.

A) SVM (Sigmoid) Performance by Person, Coloured by Gamma



B) SVM (Sigmoid) Performance by Person, Coloured by C

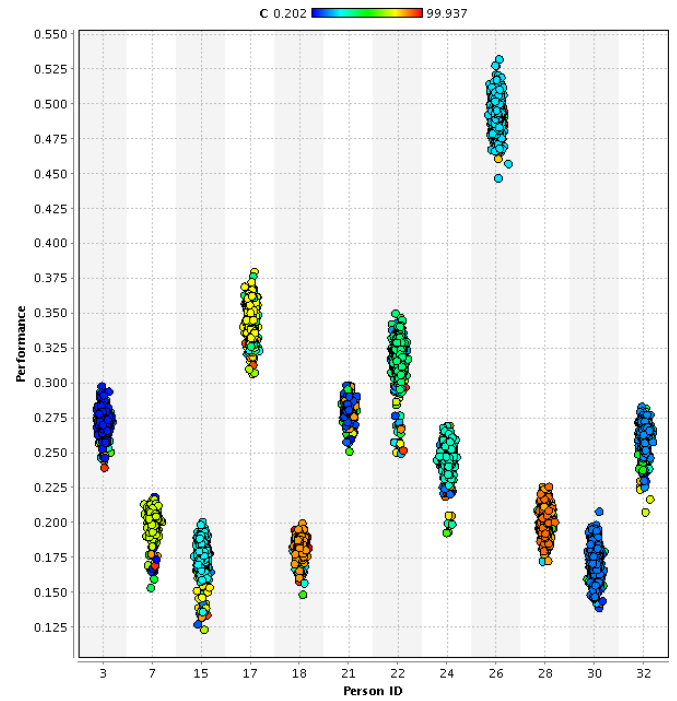

C) SVM (Sigmoid) Performance vs. Gamma, Coloured by Person

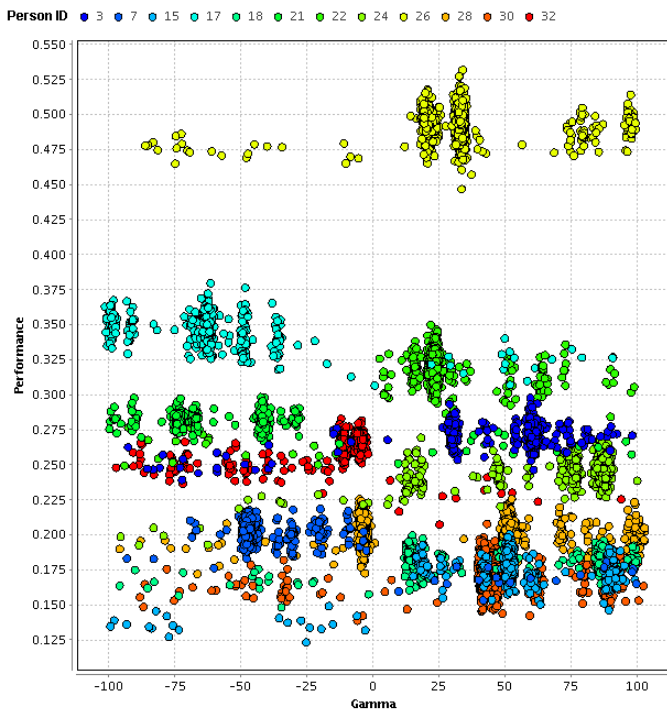

D) SVM (Sigmoid) Performance vs. C, Coloured by Person

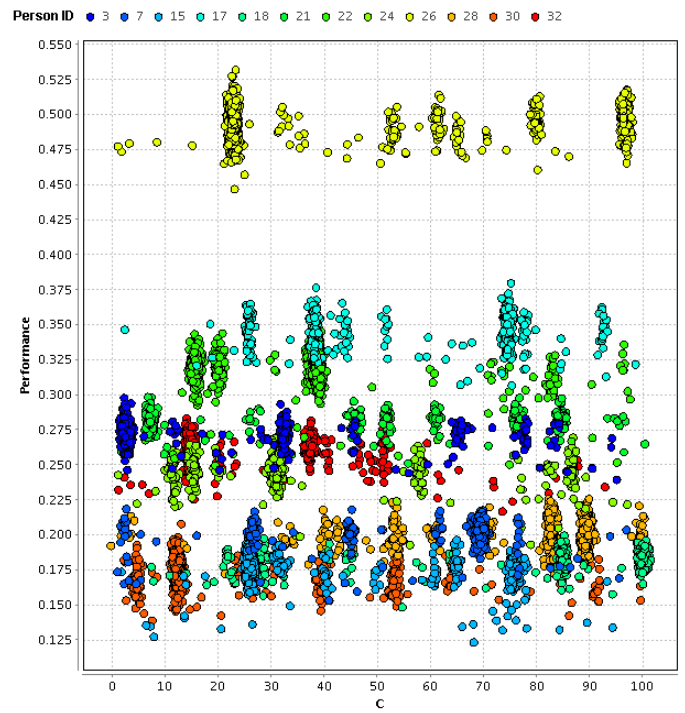
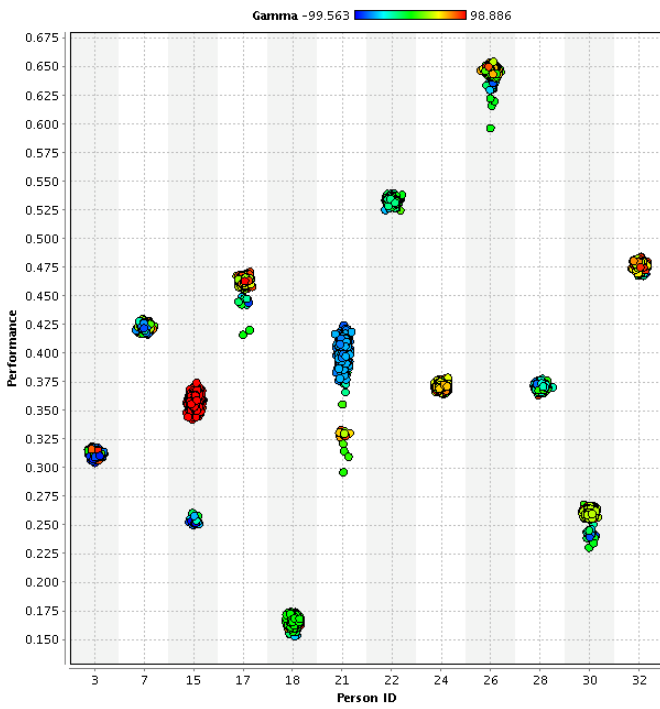
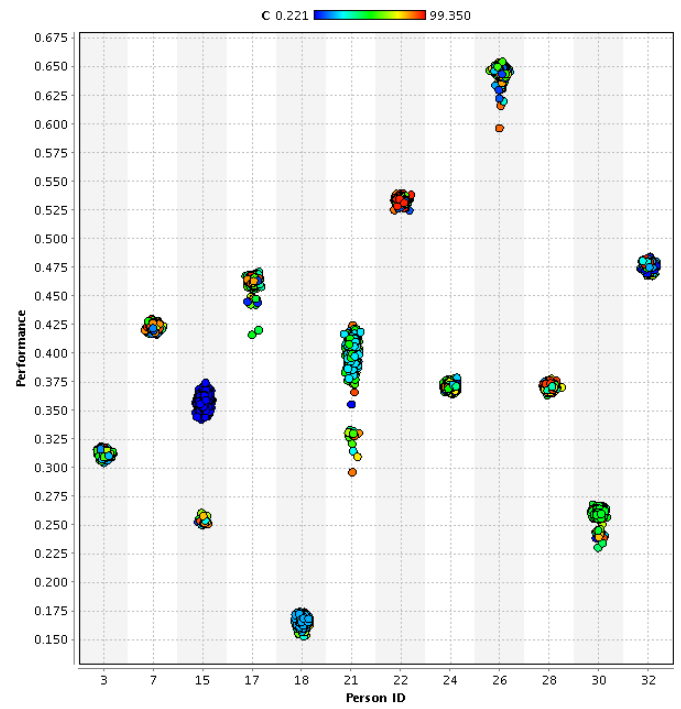

Figure 312: Sigmoid kernel SVM tuning for grid

A) SVM (Sigmoid) Performance by Person, Coloured by Gamma



B) SVM (Sigmoid) Performance by Person, Coloured by C



C) SVM (Sigmoid) Performance vs. Gamma, Coloured by Person

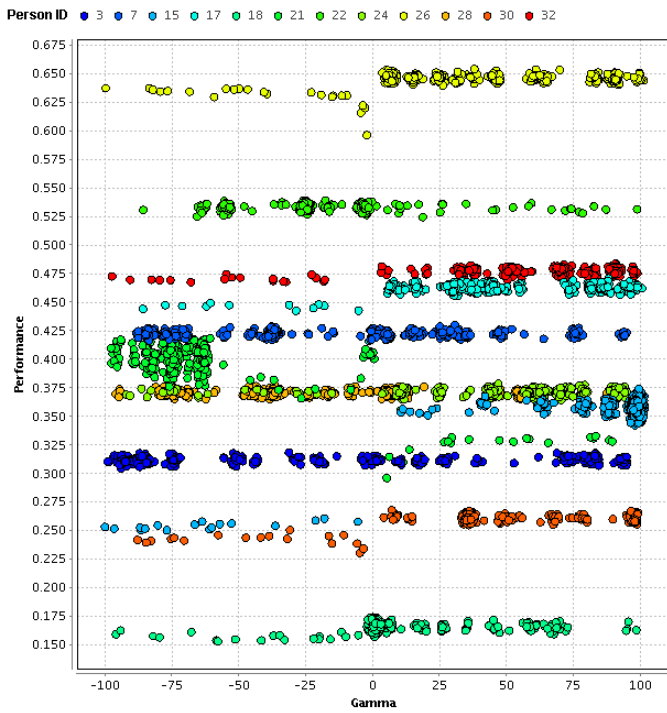

D) SVM (Sigmoid) Performance vs. C, Coloured by Person

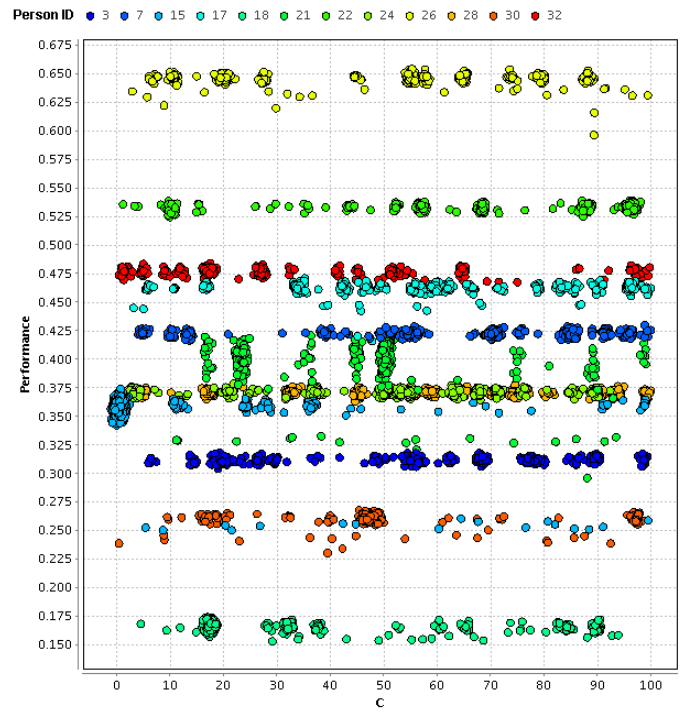

Figure 313: Sigmoid kernel SVM tuning for cluster

11.7.5. Comparison of SVM Kernels

The radial basis function kernel was the best performing kernel in the tuning phase of this experiment, providing an accuracy of 49%, approximately 9% better than any other kernel, as shown in Table 25. The performance of the SVM (using the radial basis function) was evaluated against all participants, as shown in Figure 314, where cluster labelling continued to perform well.

Table 25: Performance of different SVM kernels across participants used for tuning purposes.

Person ID	Sigmoid			Polynomial			RBF			Linear		
	Cluster	Grid	Δ	Cluster	Grid	Δ	Cluster	Grid	Δ	Cluster	Grid	Δ
3	31.2%	30.1%	1.1%	31.2%	35.9%	-4.6%	51.1%	41.9%	9.2%	31.2%	2.5%	28.7%
7	42.3%	21.8%	20.5%	42.3%	29.8%	12.6%	49.0%	33.0%	16.0%	22.4%	14.6%	7.8%
15	37.1%	19.9%	17.2%	35.0%	22.9%	12.1%	51.5%	40.0%	11.5%	17.3%	11.3%	6.0%
17	46.4%	37.8%	8.6%	46.4%	46.9%	-0.5%	52.7%	50.9%	1.8%	8.3%	46.9%	-38.6%
18	17.3%	19.9%	-2.6%	17.1%	21.8%	-4.8%	22.0%	28.5%	-6.5%	17.1%	17.9%	-0.8%
21	41.9%	29.8%	12.1%	41.9%	37.0%	4.8%	50.5%	42.0%	8.5%	27.2%	4.0%	23.2%
22	53.4%	34.9%	18.5%	53.3%	37.7%	15.5%	63.5%	52.4%	11.1%	1.5%	7.8%	-6.3%
24	37.2%	27.0%	10.2%	37.1%	32.3%	4.9%	43.3%	38.3%	5.0%	20.9%	2.7%	18.2%
26	64.7%	52.8%	11.9%	64.7%	60.4%	4.3%	66.9%	62.6%	4.3%	23.5%	12.8%	10.7%
28	37.2%	22.7%	14.5%	37.2%	30.6%	6.6%	44.5%	34.0%	10.5%	15.6%	2.5%	13.1%
30	26.4%	20.8%	5.6%	26.2%	22.0%	4.1%	34.2%	32.6%	1.6%	17.0%	12.8%	4.2%
32	47.8%	28.5%	19.3%	47.7%	33.2%	14.5%	59.6%	39.1%	20.5%	18.0%	20.8%	-2.8%
	40.2%	28.8%	11.4%	40.0%	34.2%	5.8%	49.1%	41.3%	7.8%	18.3%	13.1%	5.3%

Confusion matrices for both label schemes are shown in Figure 315 and Figure 316. The classifier for the grid based classification scheme had mixed results in predicting emotions (PPV = 11%, to 54%). Two of the grid labels, positions 1 and 6, were not correctly classified at a rate significantly higher than chance guessing (PPV = 11%). Another label, position 8 also performed poorly (PPV = 19%). With three out of nine labels lacking good PPV results we feel this solution is ultimately a failure. The NPV values were generally quite good, except grid position labels 4 and 5 which had NPV results 85% and 82% respectively. The remaining grid position labels were useful for establishing if someone is not in a given emotion (NPV = 90% to 99%, α = 2% to 10%).

Performance by Label Type (SVM)

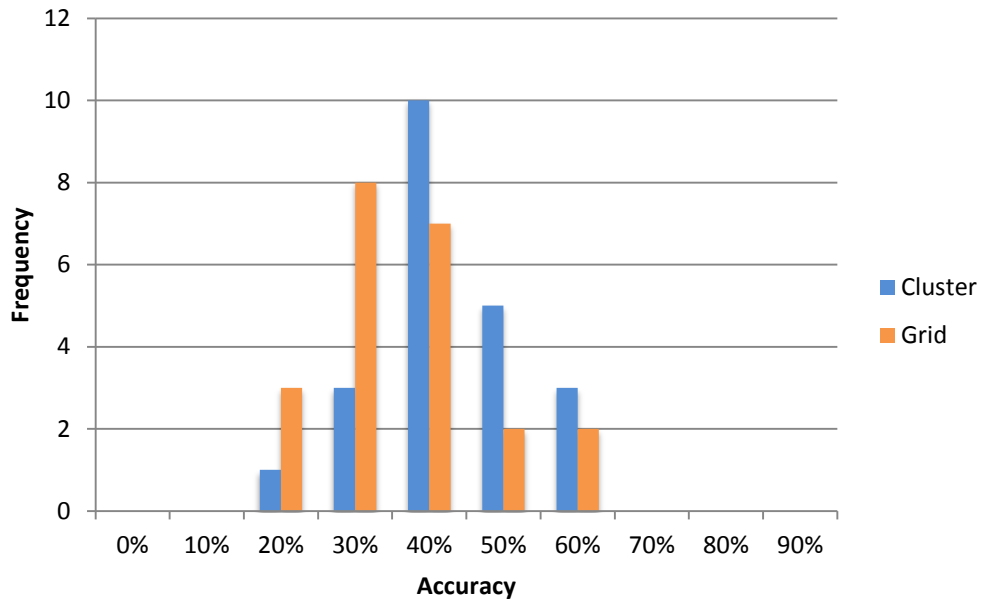

Figure 314: Performance of SVM classifier.

The classifier for the cluster based classification scheme also showed some issues with PPV for cluster 6 not being significantly higher than chance (PPV = 15%). The other labels performed reasonably (PPV = 35% to 65%). The results for establishing if someone is not in a given emotion were very mixed (NPV = 77% to 99%, α = 6% to 11%). Clusters 0, 1 and 3 stand out as being the easiest to predict (PPV = 65%, 52 and 52% respectively) and are shown in Figure 317.

		PREDICTION													
		CLUST0	CLUST1	CLUST2	CLUST3	CLUST4	CLUST5	CLUST6	CLUST7	α ,	β ,	TP,	FN,	FP,	TN
ACTUAL	CLUST0	4363	753	1499	592	984	534	454	696	11%	56%	4363	5512	2386	18589
	CLUST1	513	1948	170	157	637	196	350	736	7%	59%	1948	2759	1825	24318
	CLUST2	698	293	1659	464	211	125	549	221	11%	61%	1659	2561	3037	23593
	CLUST3	400	99	378	1662	5	321	94	45	5%	45%	1662	1342	1508	26338
	CLUST4	276	412	586	117	1912	290	156	185	9%	51%	1912	2022	2367	24549
	CLUST5	44	83	21	72	174	1002	275	221	6%	47%	1002	890	1626	27332
	CLUST6	20	6	26	9	6	14	348	13	6%	21%	348	94	1937	28471
	CLUST7	435	179	357	97	350	146	59	1153	8%	58%	1153	1623	2117	25957
PPV		65%	52%	35%	52%	45%	38%	15%	35%						
NPV		77%	90%	90%	95%	92%	97%	99%	94%	Accuracy = 45.53%					

Key

Correct Very Similar Relevant Unrelated Opposing

TP = True Positives, FN = False Negatives, FP = False Positives, TN = True Negatives

PPV = Positive Predictive Value, NPV = Negative Predictive Value,

α = False Positive Rate, β = False Negative Rate

Figure 315: Summary confusion matrix for clustered labels trained via a SVM classifier.

		PREDICTION														
		SAM9_1	SAM9_2	SAM9_3	SAM9_4	SAM9_5	SAM9_6	SAM9_7	SAM9_8	SAM9_9	α ,	β ,	TP,	FN,	FP,	TN
ACTUAL	SAM9_1	266	15	9	38	18	4	41	7	23	7%	37%	266	155	2151	29012
	SAM9_2	65	1241	259	144	224	27	293	366	343	10%	58%	1241	1721	2834	25788
	SAM9_3	47	231	1005	210	361	238	512	291	478	5%	70%	1005	2368	1475	26736
	SAM9_4	549	808	86	3024	1024	95	822	300	304	10%	57%	3024	3988	2542	22030
	SAM9_5	359	699	379	1158	2735	142	776	1193	188	10%	64%	2735	4894	2304	21651
	SAM9_6	2	5	1	6	3	96	0	3	0	2%	17%	96	20	778	30690
	SAM9_7	546	437	531	305	264	55	1539	237	300	10%	63%	1539	2675	2781	24589
	SAM9_8	27	179	33	119	147	54	142	691	11	10%	51%	691	712	2927	27254
	SAM9_9	556	460	177	562	263	163	195	530	1548	6%	65%	1548	2906	1647	25483
PPV		11%	30%	41%	54%	54%	11%	36%	19%	48%						
NPV		99%	94%	92%	85%	82%	99%	90%	97%	90%	Accuracy = 38.45%					

Key

Correct Very Similar Relevant Unrelated Opposing

TP = True Positives, FN = False Negatives, FP = False Positives, TN = True Negatives

PPV = Positive Predictive Value, NPV = Negative Predictive Value,

α = False Positive Rate, β = False Negative Rate

Figure 316: Summary confusion matrix for grid labels trained via a SVM classifier.

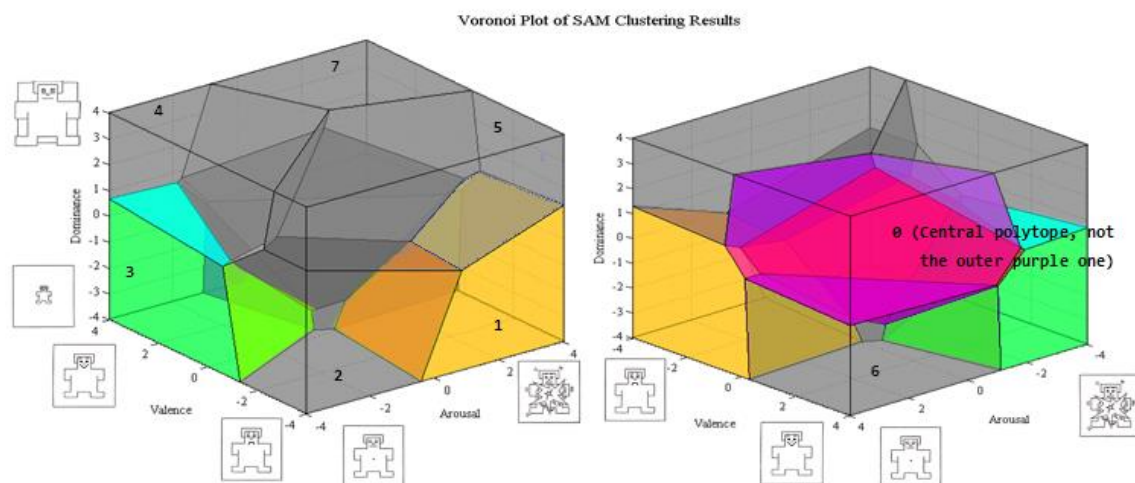

Figure 317: Clusters 0 (PPV = 65%), 1 (PPV = 52%) and 3 (PPV = 52%) highlighted for clarification of the SVM classifier results.

11.8 Selecting the Best Classifier

A full table of prediction accuracy results is shown in Table 26. The random forest classifier stood out in terms of its constantly high Positive Predictive Value (PPV Grid = 54% to 73%; Cluster = 57% to 70%) ratings across all classes, and strong Negative Predictive Value (NPV Grid = 93% to 98%; Cluster = 93% to 96%) ratings. This classifier offered 59.96% prediction accuracy for grid based labels and 64.43% for cluster based labels.

Table 26: Final performance figures for all participants across all tested classifiers. The best results are underlined.

ID	RF		NB		SVM (RBF)		k-NN		ANN	
	Cluster	Grid	Cluster	Grid	Cluster	Grid	Cluster	Grid	Cluster	Grid
3	<u>68.7</u>	<u>60.41</u>	62.13	39.59	50.52	40.99	50.79	46.03	52.16	20.98
4	<u>60.23</u>	<u>55.14</u>	39.12	23.00	40.05	33.29	44.48	46.7	29.51	24.14
5	<u>61.68</u>	<u>53.49</u>	29.02	19.59	45.35	32.54	49.91	51.53	28.86	21.50
6	<u>49.67</u>	<u>57.54</u>	38.67	53.32	32.76	29.54	42.43	36.92	34.15	22.19
7	<u>62.91</u>	<u>61.12</u>	49.35	31.89	48.65	31.92	47.57	37.39	37.89	28.62
15	<u>72.4</u>	<u>61.3</u>	55.20	37.93	49.46	38.75	62.19	56.78	50.40	34.05
16	<u>78.23</u>	<u>79.23</u>	62.13	57.17	68.40	62.22	65.71	72.09	62.57	58.80
17	<u>62.68</u>	<u>53.19</u>	37.89	34.84	52.24	50.08	46.91	50.62	34.08	37.43
18	59.88	<u>47.09</u>	<u>63.00</u>	40.88	20.71	28.05	32.59	29.54	33.25	20.05
20	<u>58.43</u>	<u>42.29</u>	37.57	13.44	32.34	23.65	44.41	33.5	34.14	18.86
21	<u>76.84</u>	<u>58.23</u>	60.61	46.65	49.97	41.42	61.61	43.77	57.56	29.42
22	<u>76.41</u>	<u>75.71</u>	69.18	56.71	62.42	52.08	65.69	54.45	45.67	37.98
24	<u>67.39</u>	<u>59.05</u>	42.17	50.79	42.47	37.76	45.96	44.47	38.26	29.52
25	<u>52.03</u>	65.83	39.44	<u>74.00</u>	41.17	34.53	44.67	47.81	32.10	34.00
26	<u>75.73</u>	<u>64.81</u>	69.58	49.36	66.35	62.23	70.67	59.31	48.87	26.79
28	<u>64.42</u>	<u>62.81</u>	56.50	54.98	46.75	33.74	44.8	42.6	47.36	34.43
29	<u>58.86</u>	62.64	42.43	<u>66.00</u>	47.04	40.94	43.3	47.21	29.29	29.55
30	<u>59.6</u>	66.03	41.49	<u>67.34</u>	32.88	31.75	43.96	31.84	35.84	24.79
31	<u>69.66</u>	<u>60.2</u>	59.43	22.00	53.63	43.01	60.44	46.19	43.21	30.60
32	<u>60.04</u>	<u>62.99</u>	34.10	51.04	58.59	44.13	52.31	44.84	33.49	28.56
33	<u>79.18</u>	<u>68.94</u>	47.81	21.72	55.13	41.19	63.04	54.9	46.02	32.50
34	<u>66.7</u>	<u>53.57</u>	58.49	30.56	45.12	43.39	51.44	47.01	37.60	28.08

All classifiers produced results that are acceptable and broadly applicable to many human computer interaction applications. Figure 318 shows the classifier performance results graphically, and highlights why the random forest classifier is a good choice in that its worst case performance never drops below 50% prediction accuracy.

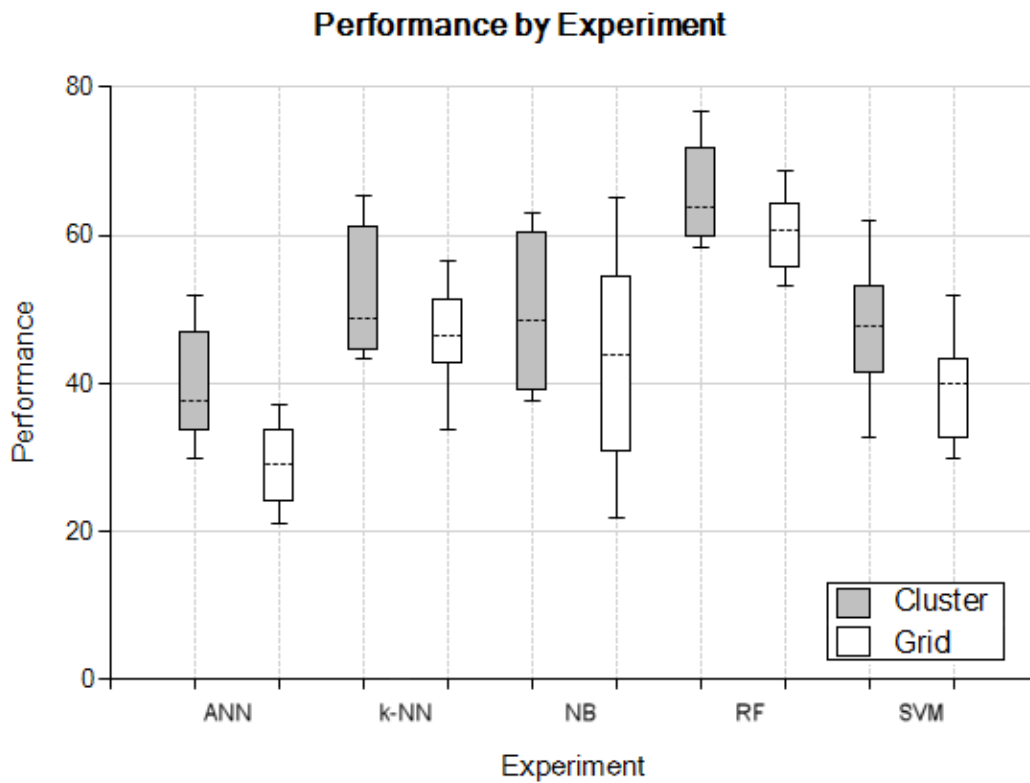

Figure 318: Performance distributions by classification task. Results are in pairs (cluster and grid labels) for each classifier. The cluster results are in grey, while the grid results are in white.

11.9 Conclusion

This chapter was created with the goal of answering the following four questions:

1. Of the candidate classifiers, which best performs this task?
2. Which features should be used for classification purposes?
3. How does the performance of classifiers vary for our different types of class labels?
4. How does the performance of classifiers vary across participants?

The candidate classifier which best performed the classification task was the random forest classifier. It provided a constantly high Positive Predictive Value (PPV Grid = 54% to 73%; Cluster = 57% to 70%), and a strong Negative Predictive Value (NPV Grid = 93% to 98%; Cluster = 93% to 96%). Overall the classifier offered 59.96% prediction accuracy for grid based labels and 64.43% for cluster based labels.

We found a set of features which were suitable for classification purposes. A separate feature set was used for Grid and Cluster based labels which used 21 and 11 features respectively. Both sets used ECG, EMG and GSR based features, however the feature set for Grid labels used respiration and temperature data as well. The coverage of features used, strongly correlated with what we were expecting given the information available in the literature reviews (Chapters 3 and 4).

While both labels were considered worthwhile, we found the Cluster based labels to be generally superior in terms of performance and features used. Our findings were that cluster based labels performed the strongest most frequently; being the best labelling scheme for about 70% of participants and being of equal value for about 10% of participants.

As covered in the literature review, the performance of emotion classifiers can be a very person specific task, as was the case in this work. With only a few exceptions the RF classifier was the best choice for each participant and the ANN classifier the worst, as shown in Figure 319.

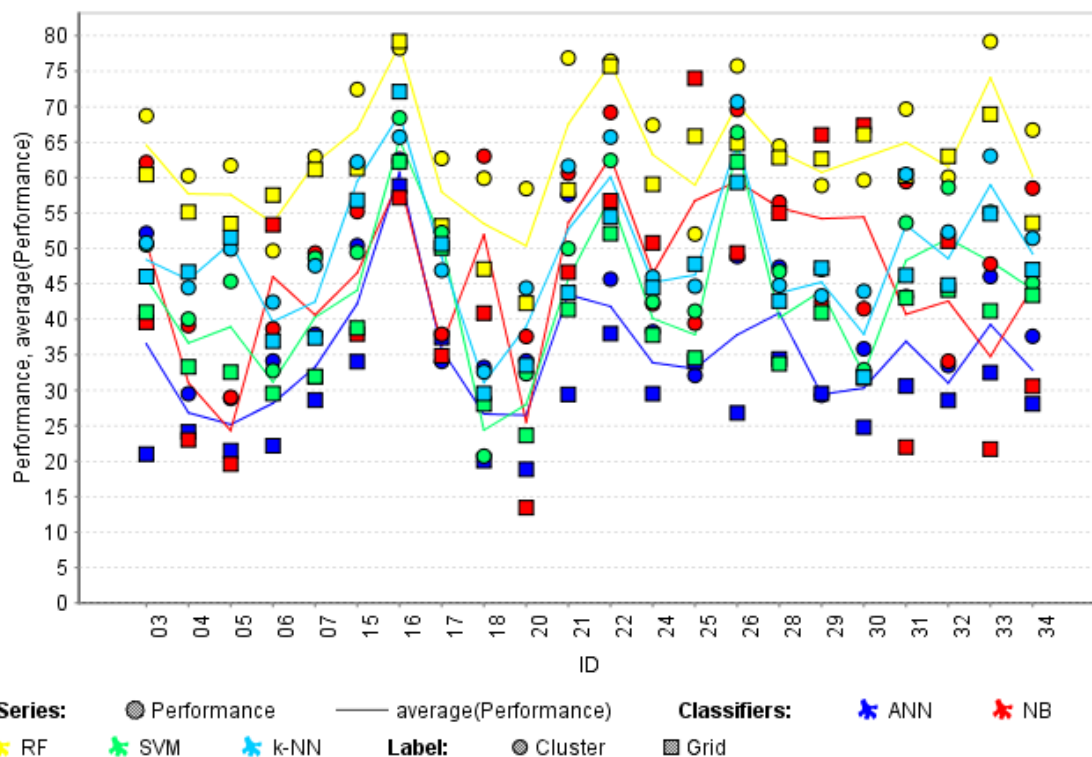

Figure 319: Performance (prediction accuracy) by participant. Results coloured by classifier with average performances indicated by the lines. Squares show results for Grid labels and circles Cluster labels.

While most classifiers show strong correlation in participant specific performance, the naïve Bayes classifier showed a relative preference for participants 6, 18, 25, 28, 29 and 30 while performing relatively poorly for participant 5. We were unable to determine the cause of this effect, and cannot make any significant speculation on this without a larger data set.

11.9.1. Comparison with other works

At the beginning of this chapter we identified several works with which this thesis may be comparable. These works used similar amounts of weakly induced emotional states and they were conducted on a reasonable amount of participants (at least 10).

These requirements gave us the studies to which this portion of the work is most applicable; namely:

- Nasoz et al., (Nasoz, Alvarez, Lisetti, & Finkelstien, 2003)
 - 24 participants, 6 emotional states, 69% accuracy;
- Takahashi (Takahashi, 2004)
 - 12 participants, 6 emotional states, 42% accuracy;
- Lisetti & Nasoz (Lisetti & Nasoz, 2004)
 - 29 participants, 6 emotional states, 84% accuracy.

Our work faces a task more difficult than that of these studies as we are attempting to differentiate between 8 and 9 emotional states; however, despite this, our results appear to be in the middle range of the performances obtained by the other available studies. In this respect, the 59.96% prediction accuracy for grid based labels and 64.43% prediction accuracy for cluster labels that we have achieved is on par with existing accuracy. The main achievement of this portion of this work is expanding the amount of emotional states that can be readily distinguished. It is also important to note that the cluster based labels performed well. This is important because these emotional labels are formed with use of the Dominance feature, which is often discarded when working with SAM results (Surakka & Anttonen, 2005), (Feldman, 1995), (Lewis et al., 2007) & (Kulic & Croft, 2007).

12.0 Conclusion

“When I am working on a problem, I never think about beauty but when I have finished, if the solution is not beautiful, I know it is wrong.”

- Buckminster Fuller (1895- 1983)

In working towards meeting our research goals, we have made contributions in a number of areas. In this work we conducted an experiment in Physiological Pattern Recognition (PPR) using six different physiological recordings, namely the: Electrocardiogram (ECG), Blood Volume Pulse (BVP), Galvanic Skin Response (GSR), Facial Electromyography (EMG) for the corrugator muscle, Skin temperature and Respiratory rate. In this experiment, 33 participants were shown 32 IAPS slides in order to create 'weakly induced emotions'; recordings of the participants' physiological state were taken as well as a self report of their emotional state using our customised Self Assessment Manikin (SAM) hardware. The collected data was processed using a set of signal processing and feature extraction techniques. The extracted features were analysed and then a set of classification experiments were conducted.

Our work is targeted towards resolving issues related to enabling electronic devices recognise human emotions relevant to computing tasks. With this in mind our research goals were:

1. Can the PPR experimental procedure be improved?
2. Can the analysis of PPR data be improved?
 - Will an application of various classification algorithms assist in improving results?
 - Can we discover new signal features that will improve classification results?
 - Can improvements in signal pre-processing techniques (cleaning, normalising, and correction) produce better classification results?
3. Can we create a PPR system that in some way also predicts the Dominance factor of the emotion being examined?

An important aspect of this work is an attempt to improve on previous works by applying better equipment, higher frequency recordings and improved signal processing with a wider set of features which are less affected by noise. We are also trying to create an emotion classification system that is more useful for electronic devices in terms of the number of emotions identifiable and the representation of the Dominance axis (of emotional space).

12.1 Contributions

In this section we review the major contributions this work has made to the field. We carried out two separate reviews of current literature. One review was of Emotion and PPR from a neurological, physiological and psychological basis. The second is an exhaustive look at facial muscles from the perspective of PPR using EMG. This review of facial muscles identified the importance of the Corrugator Supercilii in emotion recognition experiments.

In the following material, we cover our contributions to the setup of PPR experiments including a novel hardware SAM device. Followed by our creation of a formal method for selecting IAPS stimulus was proposed which will help resolve issues of selecting slides when many factors must be considered. We then outline contributions made to processing and feature selection from physiological signals, followed by our method of labelling emotions for classification.

12.1.1. Review of Physiological & Neurological Processes of Emotion

The nature of emotion was studied in chapter 3, where we examined emotion from both neurophysiological and a neuropsychological points of view. We explored various methods of working with emotion, in terms of stimulating, observing and representing emotion. We adopted various tools and methodologies for the purpose of this work, including:

- The International Affective Picture System (IAPS) (Lang, Bradley, & Cuthbert, 1997) as a method and resource for stimulating emotion;
- A dimensional view of emotions (Osgood, Suci, & Tanenbaum, 1957) expressed by three axis Valence, Arousal and Dominance;
- The Self Assessment Manikin (SAM) (Bradley & Lang, 1994) to obtain a self report of the emotions people were feeling.

The chapter provides a useful, up-to-date review of affective sciences subject matter from a PPR perspective. Only recently have similar collections of information been published (with loose ties to PPR) e.g. Davidson, Sherer, & Goldsmith 2009. However our approach is organised biologically and focussed on PPR relevant issues.

12.1.2. **Facial Muscles**

The field of facial muscle electromyography for PPR was examined in depth to produce a very extensive survey of the facial muscles from a PPR standpoint. This was concluded with a set of trials using posed facial expressions, which highlighted the usefulness of Corrugator Supercilii muscle in PPR tasks.

We showed that the Corrugator Supercilii:

- Was significant in its correlation to emotional state;
- Was not involved in facial displays meant to mask emotion;
- Produced unique and identifiable signals for expressions of frowning, pain, desperation and effort.
- Was not subject to the same level of conscious control as other facial muscles.

In addition to providing support for the use of the Corrugator Supercilii in affective computing; our contribution to facial muscle electromyography is significant because we did a full review (every muscle) from a PPR perspective. There is no similar review available (from a PPR perspective). We also published a ‘reference’ set of EMG recordings that show major claims made in previous works can be reproduced. This is significant, because all results were reproduced on one piece of hardware and presented in a common scale and format. This makes the chapter a valuable resource for directly comparing electromyography across different facial muscles.

12.1.3. **SAM**

One of our innovations (Creemers & Hingston, 2010) was a hardware implementation of the Self Assessment Manikin (SAM). Used correctly this device allows the user to provide feedback in a manner that minimises muscular action likely to introduce artefacts into the physiological signals being recorded. This device (shown in Figure 320) was produced after investigating existing devices and two of our own novel devices. We found our hardware device was an optimal solution for:

- Reducing EMG interference in the ECG induced by muscle action and various other usability issues;
- Simplicity of use;

- Minimising unwanted emotional impact on the user;
- Ease of synchronisation with physiological recordings made during the experiment.

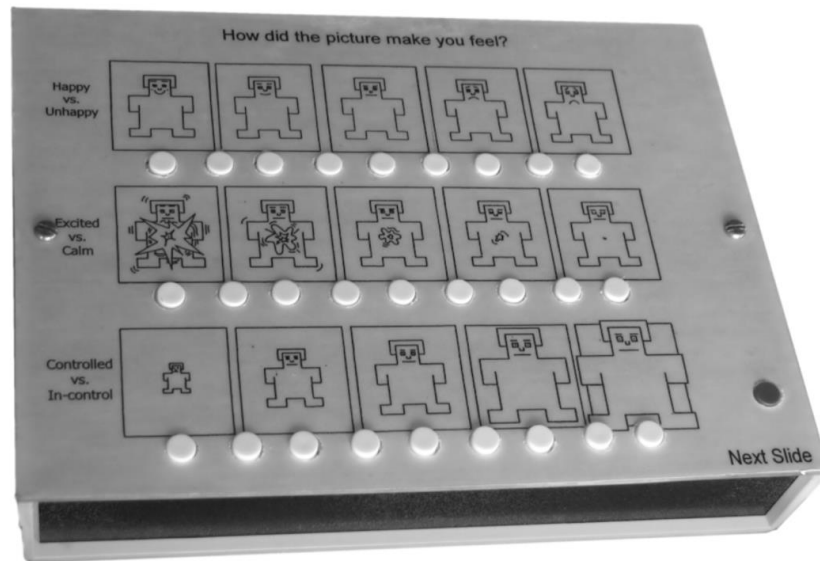

Figure 320: The hardware Self Assessment Manikin (SAM) device developed.

12.1.4. Stimulus Selection

We employed a novel, evolutionary method to select stimulus slides from the International Affective Picture System (IAPS) (Lang, Bradley, & Cuthbert, 1997). This algorithm had to balance a large variety of requirements based on information available from previous studies. These requirements for the slideshow we created were to:

- Stimulate a broad section of the Arousal / Valence / Dominance emotional space;
- Utilise slides that have been evaluated with low standard deviation in previous experiments (i.e. the outcome is predictable);
- Use around 30 slides as an ideal show length;
- Prefer the use of slides that have shown consistent SAM ratings across multiple studies;
- Where possible use slides that produce a similar response in male and female participants;
- Avoid slides with an obvious cultural bias;

- Avoid slides which are overly graphic, sexual or instructive so as to comply with Western Australian laws;
- Slides should appear overly dated (70's hair styles, old model cars, etc.).

After the experiment, we established that for the most part our participants reacted to the stimulus in a manner predicted by previous works. In this respect our selection was successful. We found some slides which did not gain the reactions expected from previous studies and found that these slides were all of similar theme(s). We proposed that the differences we discovered were due to the Australian cultural biases of our participants. This is both an expected and normal outcome for studies not conducted in America and the variances observed correlate with the results obtained by Massavelli (2010). In this regard we have established a formalised method for slide selection and contributed to the understanding of Australian cultural biases.

This portion of the work is a significant contribution because, as noted in section 6.4, there exists little in the way of formal methods for stimulus selection in related works. With many researchers still using informal techniques to select stimuli, our technique has the potential to be a 'milestone' in this area.

12.1.5. **Signal Processing**

In the signal processing phase of this work the ECG signal was examined extensively. Several algorithms to de-noise the signal were investigated and a wavelet approach was found to be optimal. A real-time median filter was built for baseline correction of the ECG signal as this technique does not affect signal morphology, and this is important towards our goals of accurate feature extraction. Median filtering was also the only portion of the work not, initially, applicable to real time systems. Creating a real-time version of the algorithm will assist future PPR efforts.

Several algorithms for labelling the ECG signal were examined with a wavelet decomposition based approach by Chesnokov, Nerukh and Glen (2006) being found optimal. Typical results on our data are shown in Figure 191. Lastly a method to make all measurements of the ECG invariant to heart rate was created.

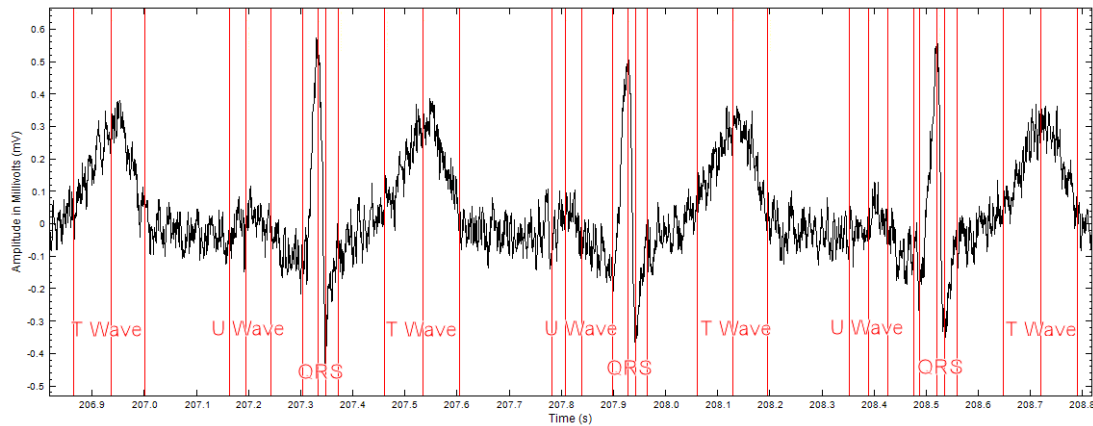

Figure 321: ECG Annotations against raw ECG signal.

12.1.6. Feature Extraction

We set about conducting a feature extraction task on the physiological data we acquired, this included the extraction of amplitude, spectral and morphological based features. We concentrated on the ECG and EMG signals as they are both complex and information rich. Some of our feature extraction techniques were novel, others were an investigation into the applicability of existing “generic” and medical techniques to the field of PPR. In all over 4000 features were extracted from the dataset and subjected to a feature selection task.

Exploring all these features assists the nature of PPR research, as many researchers either use:

- Established medical features (which may, or may not, extend to correlating with emotional state);
- A simple feature set, as implementing the algorithms involved (especially ECG feature detection and some EMG features) often exceeds practical software development time for such projects.

The EMG signal was responsible for most of the features extracted as intervals between various points in ECG morphology, from both an inter and intra beat perspective, created many possible features.

Sixteen different EMG feature extraction techniques were examined as part of this work; these features provided information in both the time and frequency domain.

This broad application of existing, medical, EMG feature extraction techniques to the field of PPR may assist future works in choosing appropriate metrics.

We also created several novel metrics for measuring the cyclic respiration and blood volume pulse signals. The novel respiration curve metric discussed in 9.4 showed some correlation with Dominance ratings. This is an important finding because Dominance is traditionally one of the more difficult ratings to find correlations with and our research goal was to improve PPR classification in terms of observed dominance. Further work is needed to statistically quantify the relationship between the respiration curve metric and Dominance results. Specifically an experiment designed with Dominance as a control variable would be needed.

12.1.7. Labelling Emotions

We created two sets of emotion labels for classification purposes which were applicable to the SAM feedback we recorded. One was based on a grid covering the Arousal / Valence emotional space. The second was derived from k-means clustering of our SAM ratings. These two labelling systems are shown in Figure 322. The labelling system resulted in nine and eight labels respectively. These labelling systems evaluated well under classification tasks, but importantly the clustering based labels allow for classification of emotional state with Dominance being represented. To date many researchers discard Dominance information as it easily confounds the classification process. We also found it was not possible to extend the grid system into this space, as this produced 27 states, a target not achievable to our classification systems.

The grid system offers a straightforward interpretation of the emotion space with gives at an immense practical advantage, in terms of using it in a computer interface. However the clustering approach offers:

- Increased accuracy;
- A decreased number of features required for the classifier;
- Encapsulation of the Dominance dimension.

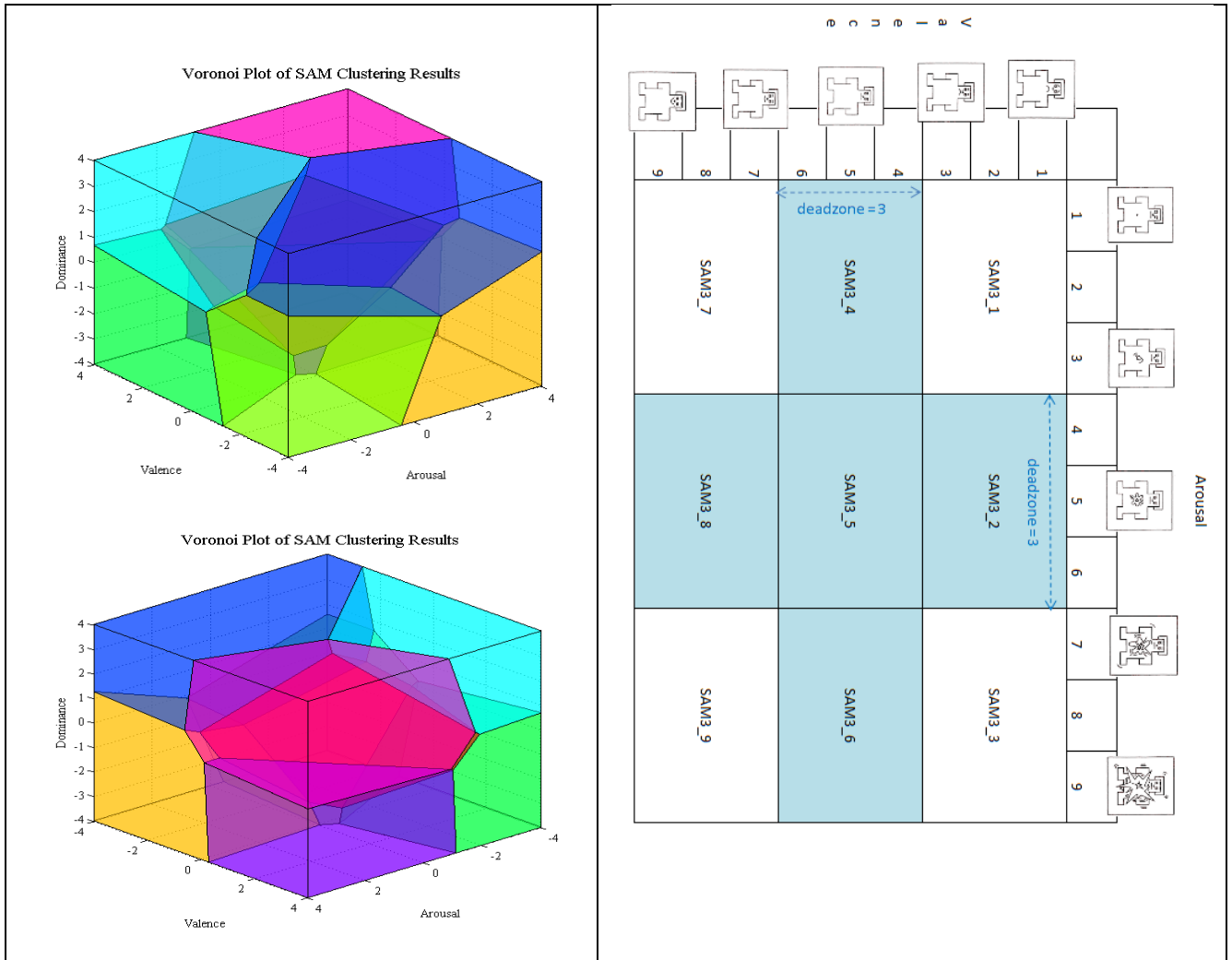

Figure 322: Emotion labelling systems. Voronoi plots of the our clustering Labels (Left) are shown from two rotations and the rating axes have been adjusted from the range [1 to 9] to the range [-4 to 4] so that 0 is neutral. The grid labels (Right) show the Valence/Arousal emotional space divided into nine different labels.

12.1.8. Classification Performance

Our work was successful in being able to differentiate between eight (cluster based) and nine (grid based) emotional states; with 64% and 60% prediction accuracy respectively. This expands the number of states that can be readily distinguished via PPR techniques while still delivering accuracy on par with existing studies which typically use two to six states.

Significantly, this was achieved on ‘weakly’ elicited emotions with Dominance being represented in the classification output. This result is directly applicable to human

computer interaction in terms of the type of emotion studied and the nature of the classification results.

Additionally we investigated five different classifiers in terms of performance for the task of detecting (weak) emotion states from physiological data. We found an advantage in using the random forest classifier over the naïve Bayes classifier, artificial neural network, k nearest neighbour classifier and support vector machine.

12.2 Future Work and Final Thoughts

When this work began the “tablet device” was still finding a home, iPads, Galaxy Tabs and the like were not around and a laptop was still a luxury. It would be interesting to investigate what physiological signals can be gleaned from hand contact with these tablets and attempt classification on just those signals.

We have focused on supervised learning in this work. There may be some merit to attempting an unsupervised learning approach to the problem,

Additionally there is no attempt made to use our data in another researchers classification framework, or use other researchers data in our framework. We suggest this may be a very useful exercise; in the extent to which it is allowed by restrictions on the data.

There is still much work needed in person independent emotion detection. We feel our ECG signal extraction techniques would help in this area as they improve on making data collected person and time independent.

A lack of person independent PPR systems may not be the technical hurdle we once envisioned. Maybe modern cloud storage would allow for person dependent classification profiles to be stored and retrieved by diverse PPR enabled consumer electronic devices.

An emerging world of Affective devices should be approached with some caution. Tools which evaluate our emotional state should be used for improving the human-device interaction. To put these tools to work as diviners of peoples personality would both be unfounded and morally wrong.

It is the author's hope that the results from this work are not used to create devices which attempt to probe a person's personality/feelings in a manner that is an invasion of privacy. Our feelings are just that. They are personal and we have evolved an array of innate abilities to (largely) choose how much of our feelings we communicate to others.

It is the author's view that our cars should not inform our insurance companies how frequently we are stressed at the wheel. Likewise our telephones should not report to the government that we are scared or being secretive. Our televisions should not glean which brands we respond to the most and potential employers should not attempt to use devices that audit our feelings, likes and dislikes. Already there are some negative affective technologies appearing and that is... worrying.

In proceeding forward with these technologies, the author advocates that scientists and engineers alike, should bear in mind two articles from the "Universal Declaration of Human Rights" (UN General Assembly, 1948)

"No one shall be subjected to arbitrary interference with his privacy, family, home or correspondence, nor to attacks upon his honour and reputation. Everyone has the right to the protection of the law against such interference or attacks." (Article 12)

"Everyone has the right to freedom of opinion and expression; this right includes freedom to hold opinions without interference and to seek, receive and impart information and ideas through any media and regardless of frontiers." (Article 19)

13.0 Glossary

Afferent	Carrying towards (inwards). Especially from the body to the brain.
Alaris	Derived from the Latin word ala (wing) used anatomically to describe something that flanks an organ.
Anguli	(Anatomy) plural of angulus; an angle, corner, or apex.
ANN	Artificial Neural Network
Anterior	Towards the front (see Figure 323)
Arousal	Emotional Factor; level of excitement
Autonomic	Concerning the involuntary nervous system
Biocybernetic	Concerning the application of cybernetics to biological science
Bio-impedance	Response of a living organism to an electric current
Buccinator	Facial muscle of the jaw (see section 4.3)
Caninus	Facial muscle of the jaw (see section 4.3)
Circumplex	Concerning a model organised in a radial fashion.
Confusion Matrix	A matrix used for the visualization of classifier performance
Corrugator Supercilii	Facial muscle used in eye expression (see section 4.4)
Cortex	The outer layer of an organ (antonym of Medulla)
Depressor	A muscle used to pull down a part of the body.
Depressor Anguli Oris	Facial muscle of the jaw (see section 4.3)
Dermatological	Relating to the skin.
Diastolic	When the heart refills with blood
Dichotomous	Divided into two branches
Distal	Away from the body (see Figure 323)
Diurnal	Daytime
Dominance	Emotional Factor; Level of control.
Dorsal	Relating to the upper side (see Figure 323)
Dot Product	A real, scalar, number which is the product of two vectors

ECG (EKG)	Electro Cardio Graph, or in German Elektrokardiogramm. A recording of the electrical activity of the heart.
Efferent	Carrying away (outwards). Especially from the brain to the body
Electrocardiogram	Measurement of the electrical activity of the heart
Electromyography	Measurement of the electrical activity of muscles
F0	Fundamental Frequency
FFT	Fast Fourier Transform
Fischer Projection	A method for projecting a 3D structure onto a 2D Plane
Frontalis	Facial muscle used in eye expression (see section 4.4)
Fuzzy C-means-Clustering	A clustering algorithm which allows one piece of data to belong to multiple clusters
GSR	Galvanic Skin Response
Homeostasis	Property of a system that regulates itself to remain stable.
IAPS	International Affective Picture System
Inferior	Below (see Figure 323)
Inferioris	(Anatomy) Below (antonym of Superioris)
Insula	Part of the brain, in the cerebral cortex
KNN	K-Nearest Neighbours
Labii	Of the lip (Latin)
Lateral	Away from the midline (see Figure 323)
Levator	A muscle used to pull up a part of the body.
Levator Anguli Oris	Facial muscle of the jaw (see section 4.3)
Levator Labii Superioris	Facial muscle of the jaw (see section 4.3)
Linear Discriminant Analysis (LDA)	A type of classifier.
Medial	Towards the midline (see Figure 323)
Medulla	The inner region of an organ (antonym of Cortex)
Medulla Oblongata	The lowermost portion (stem) of the vertebrate brain
Mentalis	Facial muscle of the jaw (see section 4.3)
Midline	Vertical axis of the body (see Figure 323)
Mimetic	(Anatomy) Of the face
Nasalis	In reference to anatomy of the nose, From the Latin for

	"nose".
Nasalis Alaris	Facial muscle of the nose (see section 4.5)
Nasalis Transversa	Facial muscle of the nose (see section 4.5)
Oblongata	Elongated in one direction
Oculi	Round (eyelike) opening
Opto-isolator	Device which transfers an signal optically (to separate electrical systems)
Orbicularis	(anatomical) Circular; often used in naming sphincter muscles.
Orbicularis Oculi	Facial muscle used in eye expression (see section 4.4)
Orbicularis Oris	Facial muscle of the jaw (see section 4.3)
Oris	(anatomical) Of the mouth
Palmer	The palm of the hand (or direction of the palm) (see Figure 320)
Platysma	Facial muscle of the jaw (see section 4.3)
Posterior	Towards the back (see Figure 323)
PPR	Physiological Pattern Recognition
Procerus	Facial muscle used in eye expression (see section 4.4)
Proximal	Towards the body (see Figure 323)
Pseudo-Gibbs	Similar to the ringing artefacts caused by the Gibbs phenomenon
QRS Complex	A portion of the ECG signal
QT Interval	A portion of the ECG signal
Quadratus	(anatomy) Quadrilateral in shape.
Quadratus Labii Inferioris	Facial muscle of the jaw (see section 4.3)
Quadratus Labii Superioris	Facial muscle of the jaw (see section 4.3)
Restylane	An injectable filler for sub dermal facial tissues
Risorius	Facial muscle of the jaw (see section 4.3)
ROC Curve	Receiver Operating Characteristic (ROC). Used to plot the performance of a binary classifier against its discrimination threshold.

Semantic	Relating to the different meanings of words
Sentograph	A two-dimensional pressure sensitive touch transducer
Somatovisceral	Of the nerves connecting the spine to the organs.
Somatovisceral	Nerve pathways connecting the spinal cord to internal organs
Spectrogram	Spectral density plotted against time.
Supercilii	(Latin) from superus (above) and cilium (eyelash)
Superior	Above (see Figure 323)
Superioris	(Anatomy) Above (antonym of Inferioris)
Systolic	When the heart is contracting.
Thermoregulatory	(Anatomical) Relating to how the body regulates its internal temperature.
Transversa	(Latin) roughly to lie across and furrow.
Triangularis	(Latin) Triangular corner
Valence	Emotional factor; positive or negative Feeling.
Wavelet	Brief oscillation, starting and ending at zero amplitude.
Zygomatic(us)	Cheekbone
Zygomaticus Major	Facial muscle of the jaw (see section 4.3)
Zygomaticus Minor	Facial muscle of the jaw (see section 4.3)

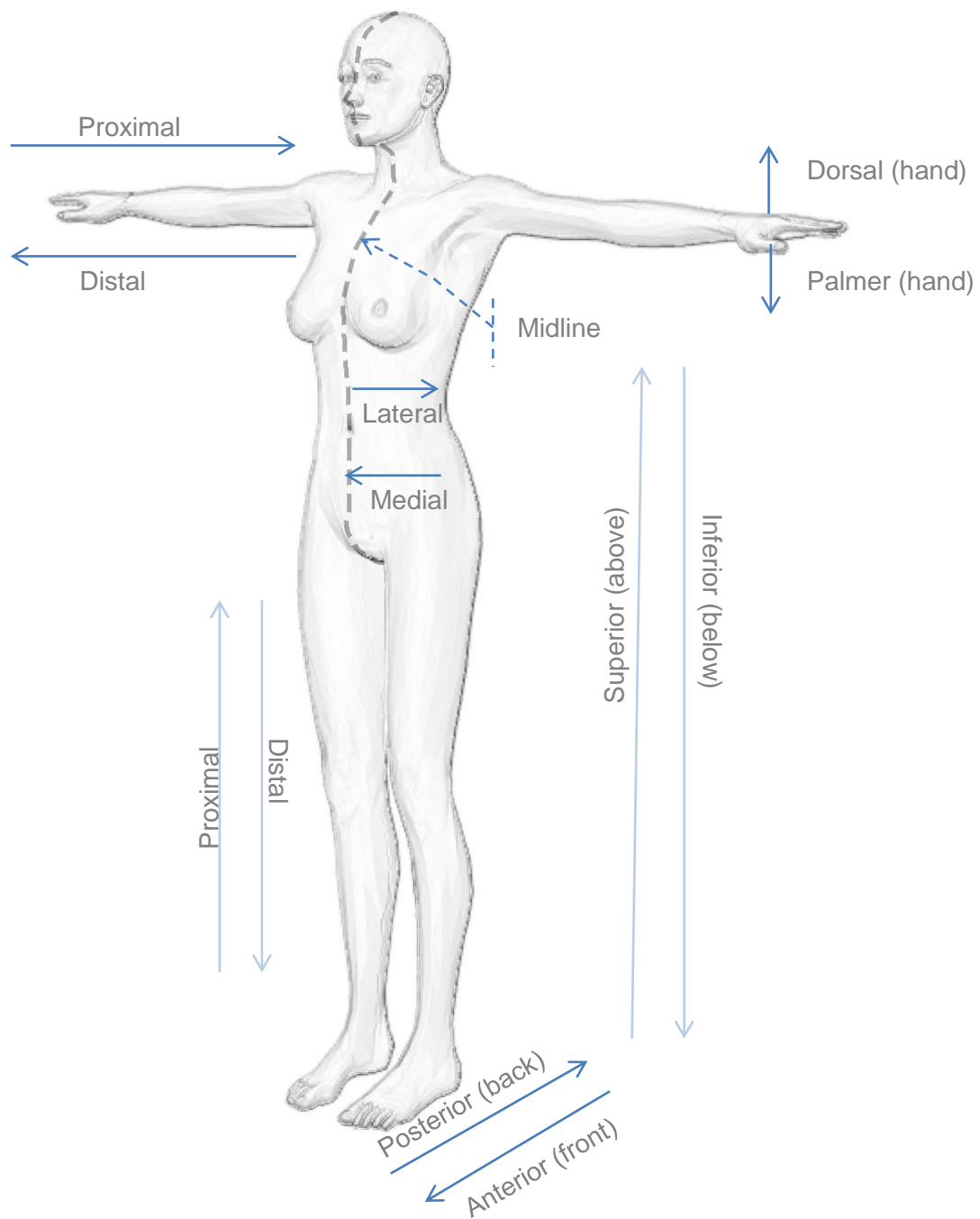

Figure 323: Diagram of human anatomical terminology

14.0 Appendix

14.1 Stimulus Slides

This section of the appendix shows a very low detail, obscured and greyscaled version of the IAPS stimulus slides¹ used in this study. The images have been deliberately “damaged” so as to prevent the content “leaking” to the public/internet.

FIGURE REMOVED TO COMPLY WITH
TERMS OF USE OF THE IAPS DATA SET.

Figure 324: IAPS slide used in this study (continued next page)

¹ THIS PAGE IS NOT TO BE COPIED OR INCLUDED IN ELECTRONIC DISTRIBUTION AS THE IAPS LICENCING DOES NOT PERMIT THIS. THIS PAGE IS NOT TO BE REPRODUCED.

Stimulus slides continued¹.

FIGURE REMOVED TO COMPLY WITH
TERMS OF USE OF THE IAPS DATA SET.

Fi

¹ THIS PAGE IS NOT TO BE COPIED OR INCLUDED IN ELECTRONIC DISTRIBUTION AS THE IAPS LICENCING DOES NOT PERMIT THIS. THIS PAGE IS NOT TO BE REPRODUCED.

Stimulus slides continued¹.

FIGURE REMOVED TO COMPLY WITH
TERMS OF USE OF THE IAPS DATA SET.

¹ THIS PAGE IS NOT TO BE COPIED OR INCLUDED IN ELECTRONIC DISTRIBUTION AS THE IAPS LICENCING DOES NOT PERMIT THIS. THIS PAGE IS NOT TO BE REPRODUCED.

14.2 SAM Evaluations User Reliability Charts

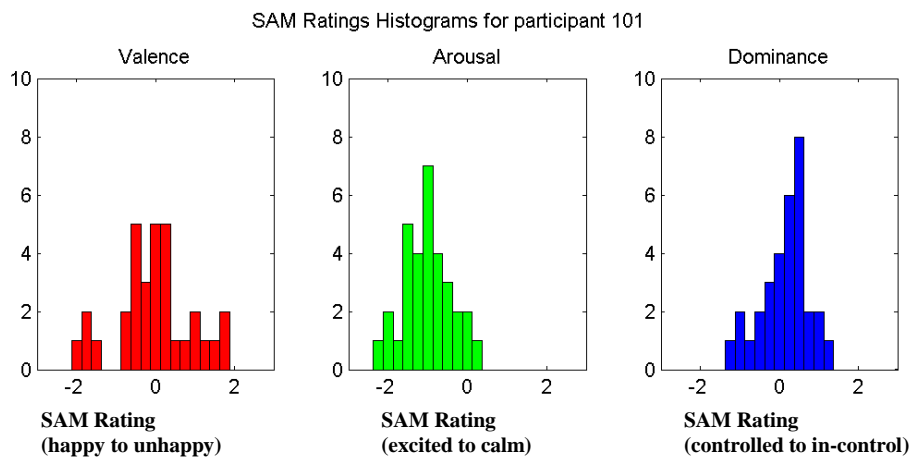

Figure 327: SAM frequency histogram for participant 1, day 1

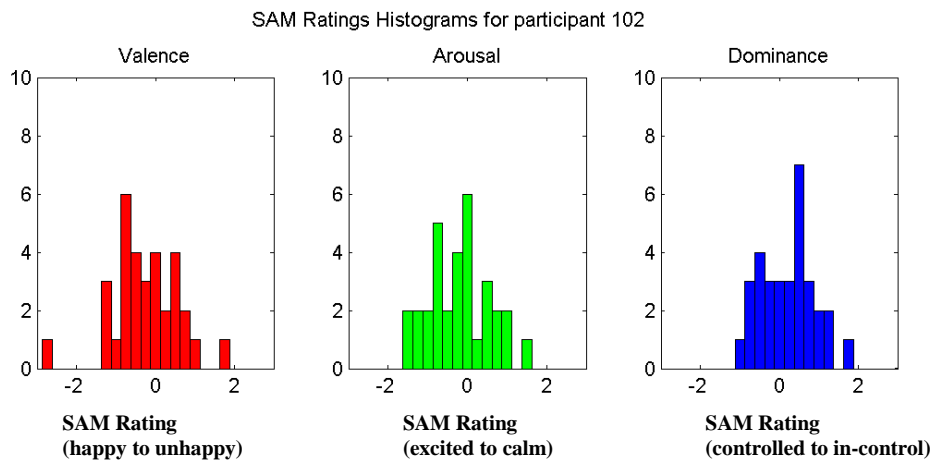

Figure 328: SAM frequency histogram for participant 2, day 1

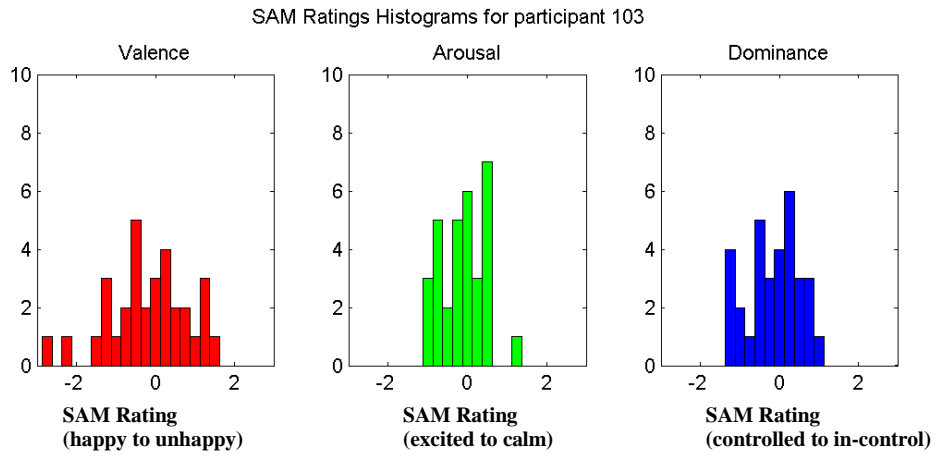

Figure 329: SAM frequency histogram for participant 3, day 1

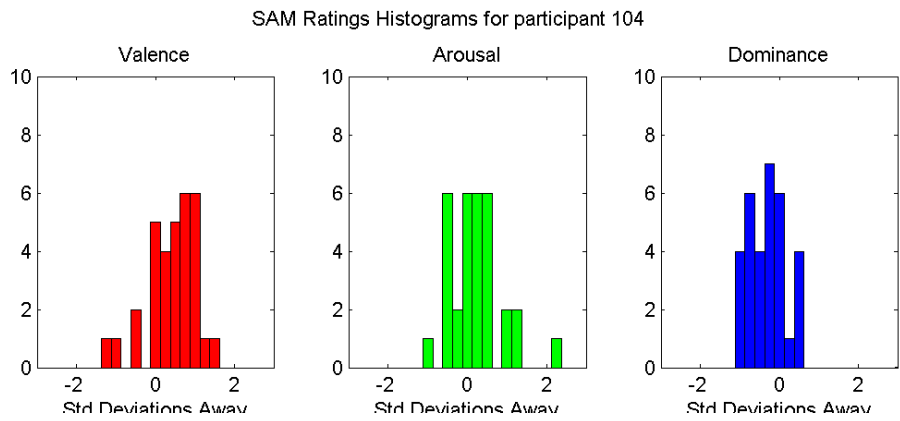

Figure 330: SAM frequency histogram for participant 4, day 1

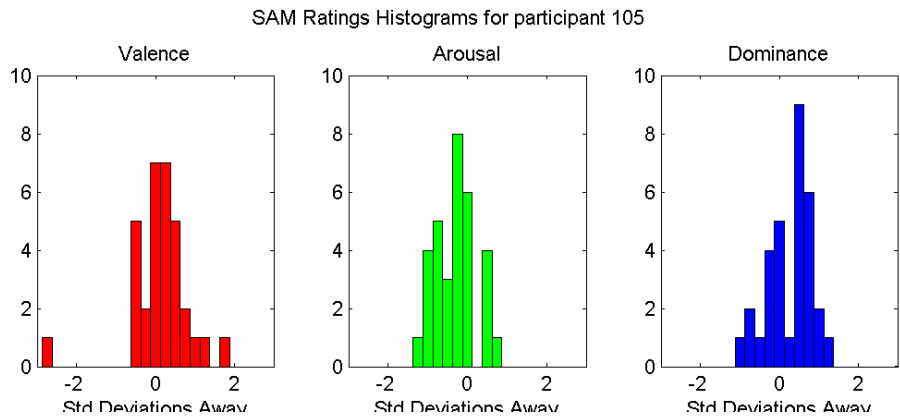

Figure 331: SAM frequency histogram for participant 5, day 1

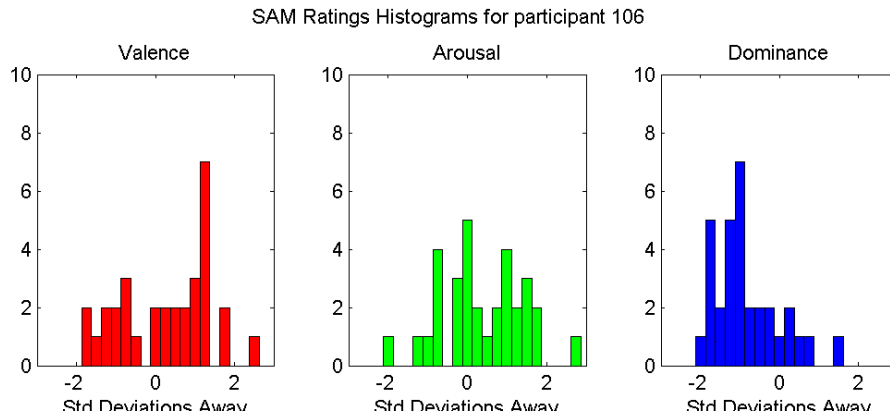

Figure 332: SAM frequency histogram for participant 6, day 1

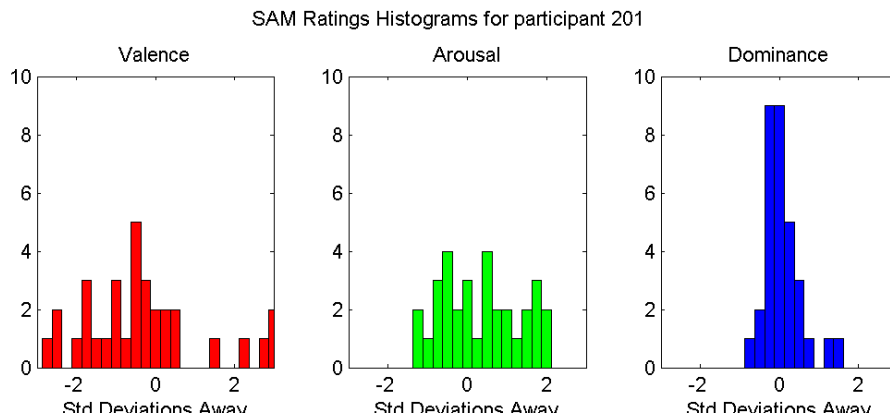

Figure 333: SAM frequency histogram for participant 1, day 2

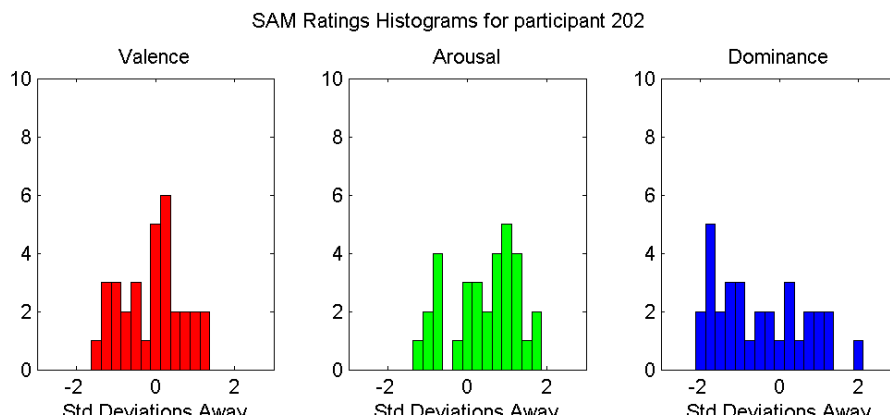

Figure 334: SAM frequency histogram for participant 2, day 2

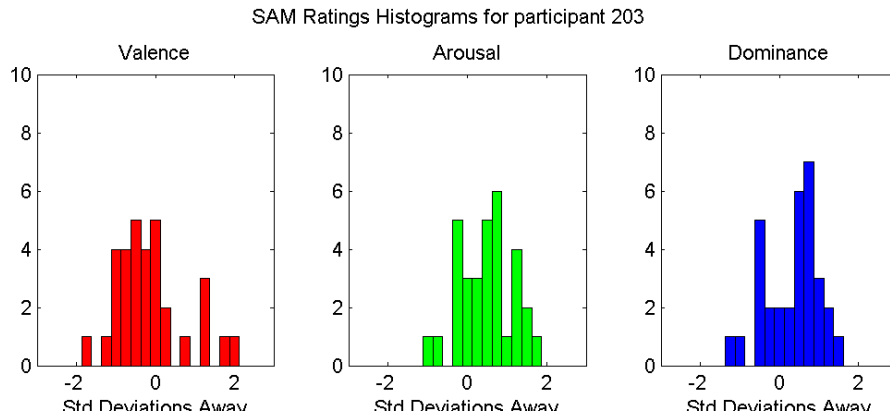

Figure 335: SAM frequency histogram for participant 3, day 2

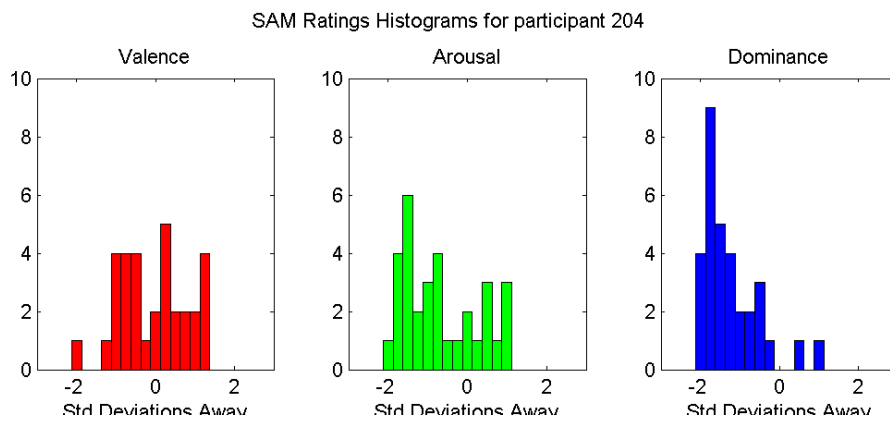

Figure 336: SAM frequency histogram for participant 4, day 2

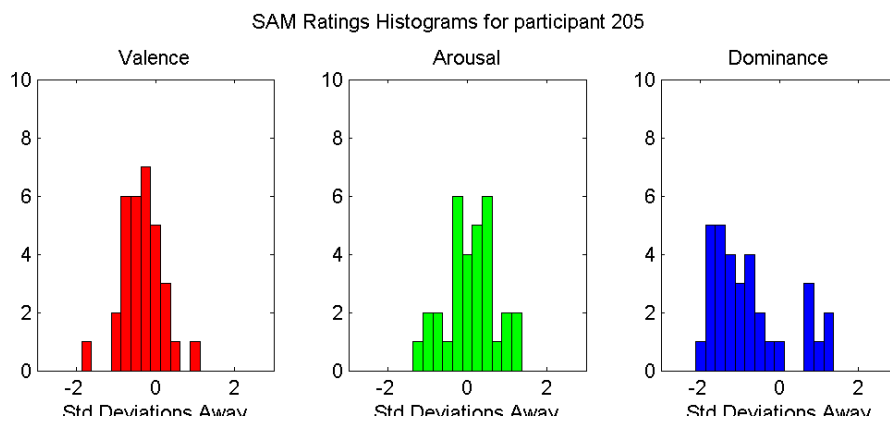

Figure 337: SAM frequency histogram for participant 5, day 2

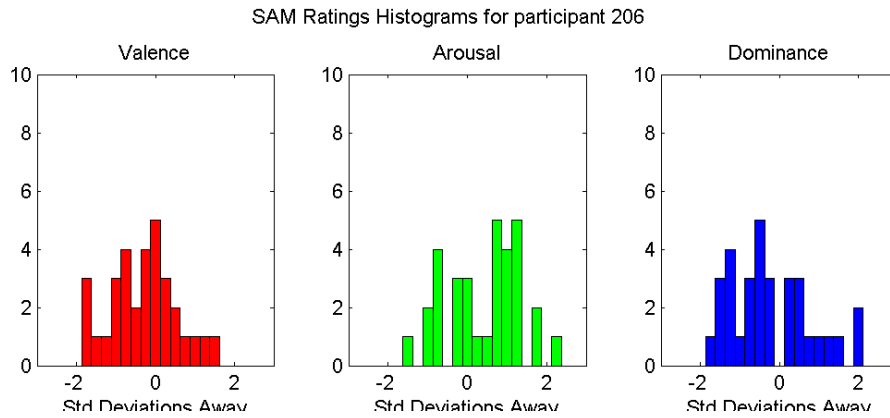

Figure 338: SAM frequency histogram for participant 6, day 2

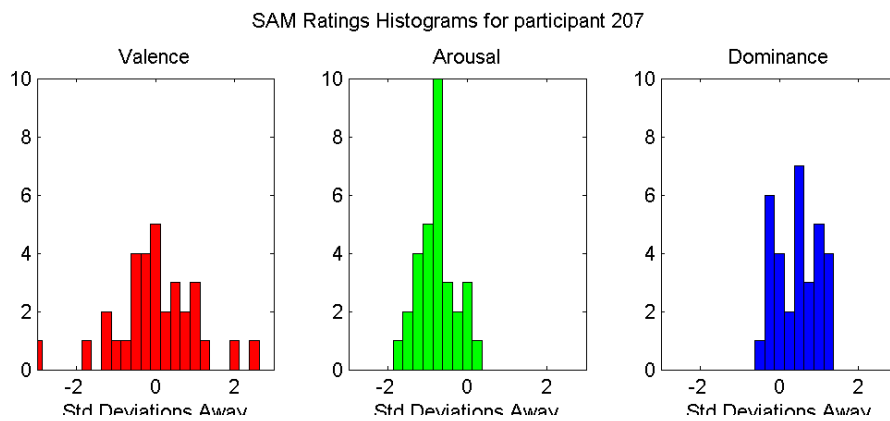

Figure 339: SAM frequency histogram for participant 7, day 2

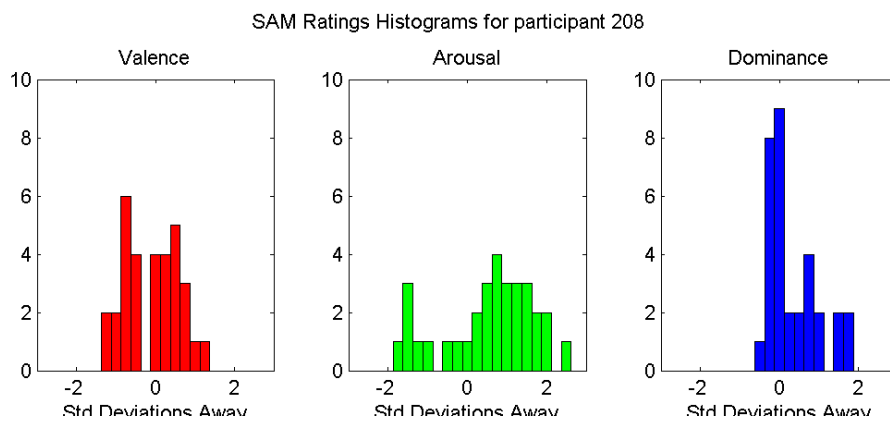

Figure 340: SAM frequency histogram for participant 8, day 2

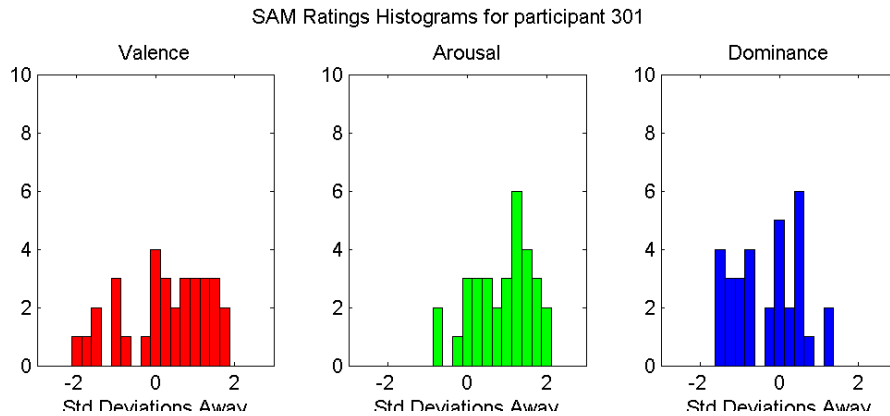

Figure 341: SAM frequency histogram for (female) participant 1, day 3

The lack of meaningful distribution for participant 301 in Figure 47 stems from this participant being 1 of only 5 females in the study. See Table 3 issue 2 for more information.

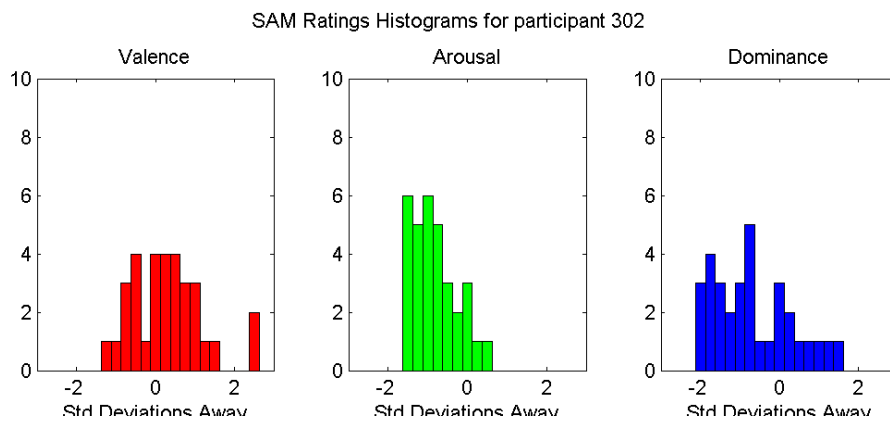

Figure 342: SAM frequency histogram for participant 2, day 3

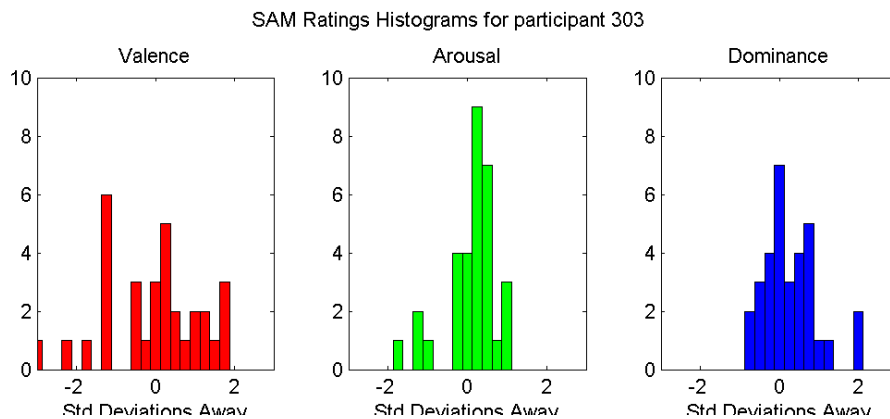

Figure 343: SAM frequency histogram for participant 3, day 3

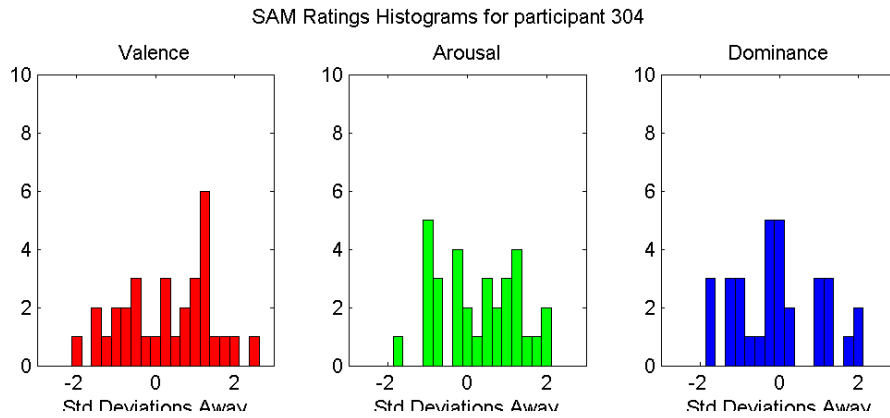

Figure 344: SAM frequency histogram for participant 4, day 3

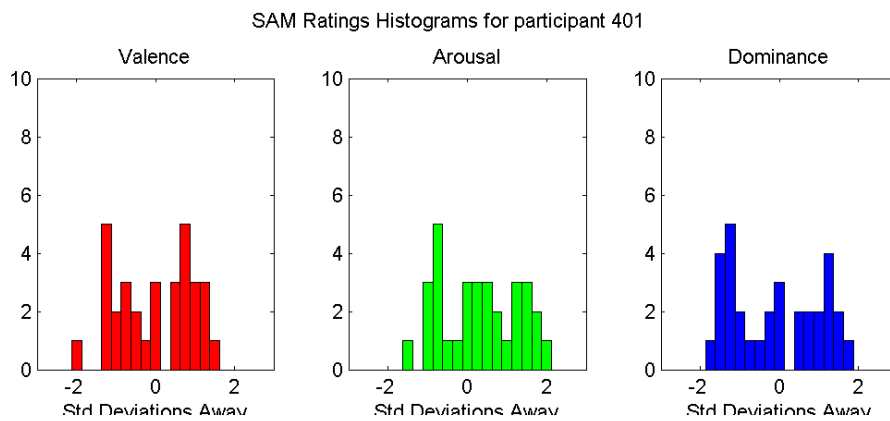

Figure 345: SAM frequency histogram for participant 1, day 4

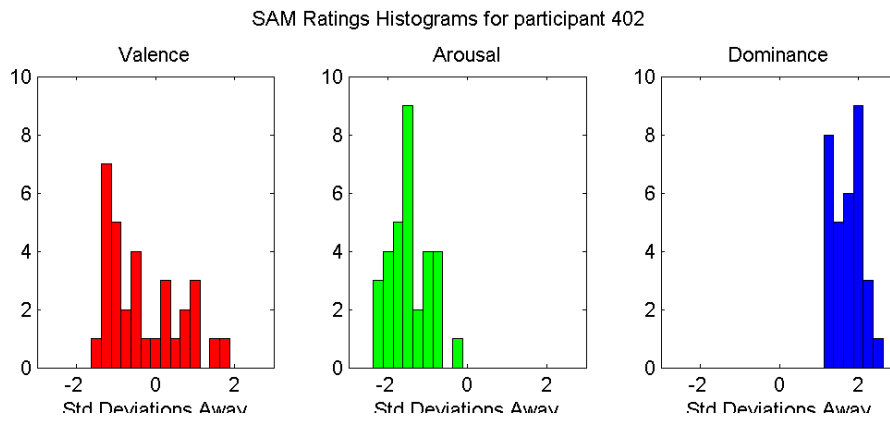

Figure 346: SAM frequency histogram for participant 2, day 4

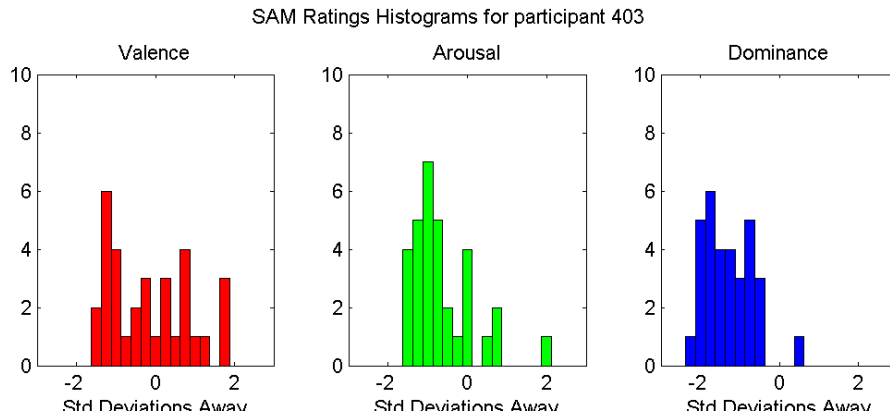

Figure 347: SAM frequency histogram for participant 3, day 4

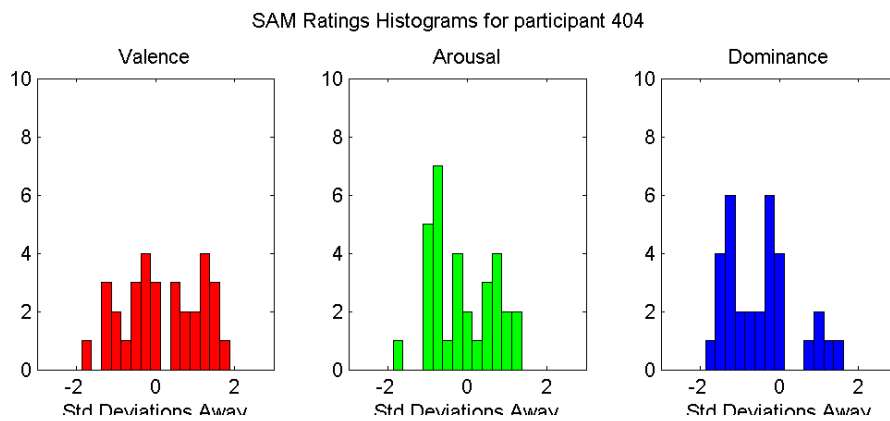

Figure 348: SAM frequency histogram for participant 4, day 4

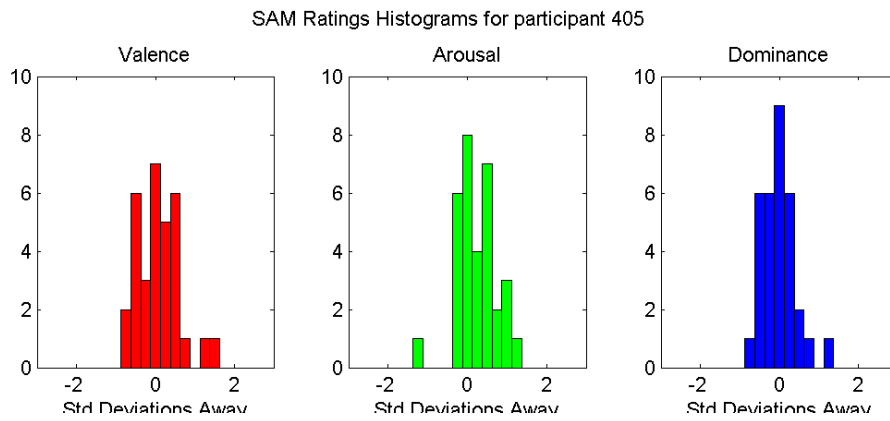

Figure 349: SAM frequency histogram for participant 5, day 4

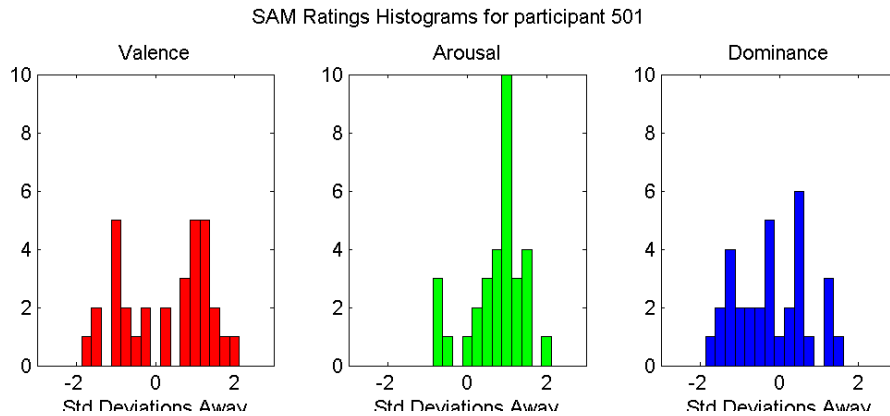

Figure 350: SAM frequency histogram for (female) participant 1, day 5

The lack of meaningful distribution for participant 501 in Figure 56 stems from this participant being 1 of only 5 females in the study. See Table 3 issue 2 for more information.

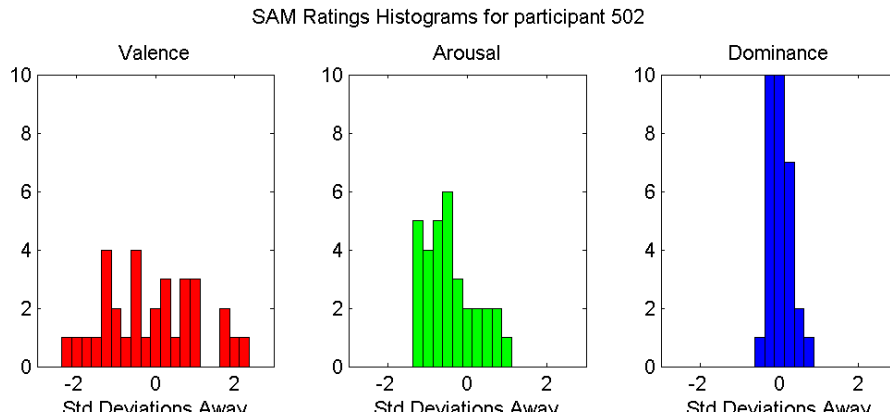

Figure 351: SAM frequency histogram for participant 2, day 5

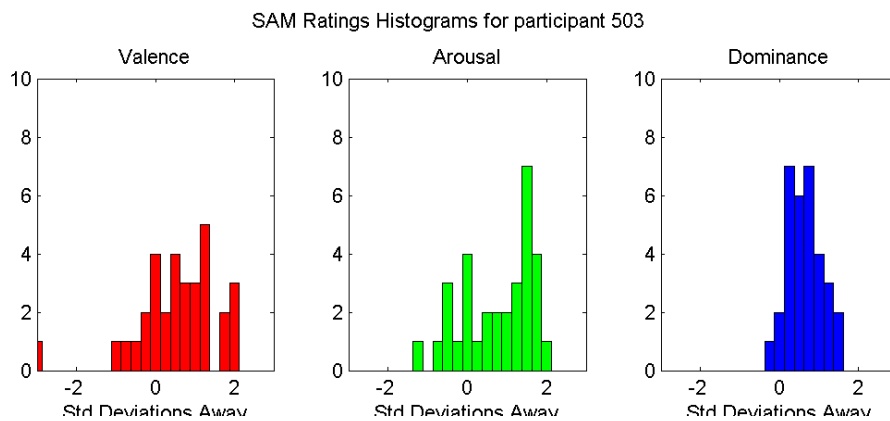

Figure 352: SAM frequency histogram for participant 3, day 5

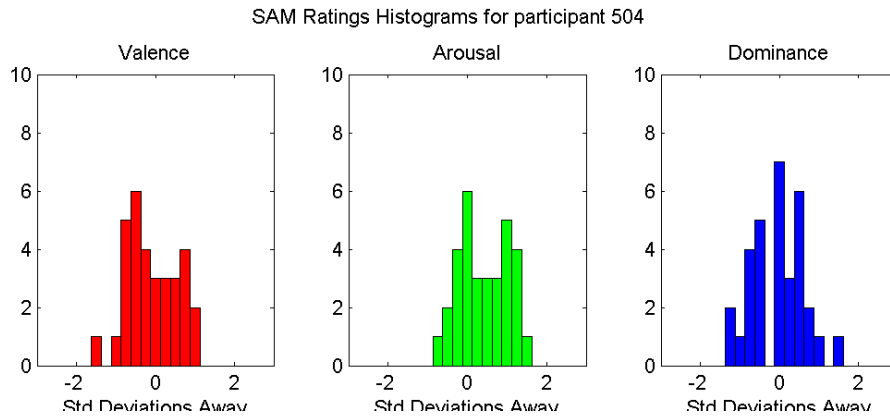

Figure 353: SAM frequency histogram for participant 4, day 5

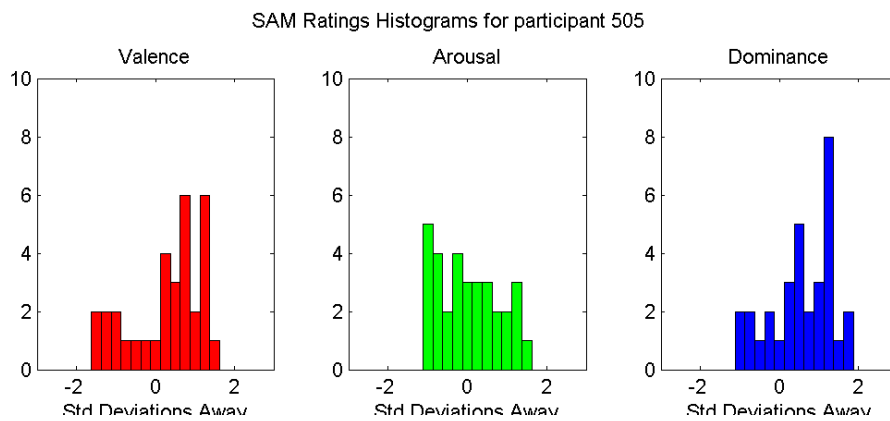

Figure 354: SAM frequency histogram for (female) participant 5, day 5

The lack of meaningful distribution for participant 505 in Figure 60 stems from this participant being 1 of only 5 females in the study. See Table 3 issue 2 for more information.

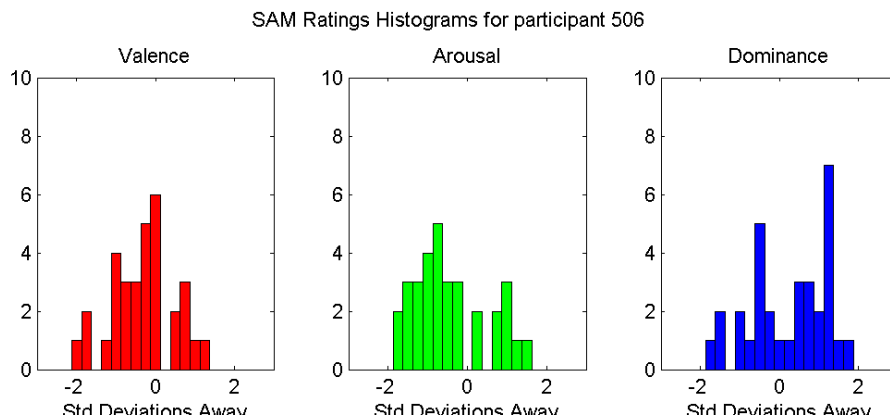

Figure 355: SAM frequency histogram for (female) participant 6, day 5

The lack of meaningful distribution for participant 506 in Figure 61 stems from this participant being 1 of only 5 females in the study. See Table 3 issue 2 for more information.

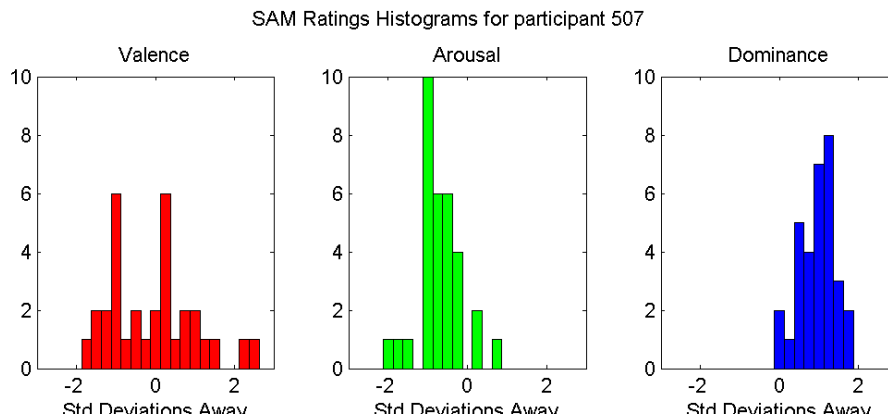

Figure 356: SAM frequency histogram for (female) participant 7, day 5

The lack of meaningful distribution for participant 507 in Figure 62 stems from this participant being 1 of only 5 females in the study. See Table 3 issue 2 for more information.

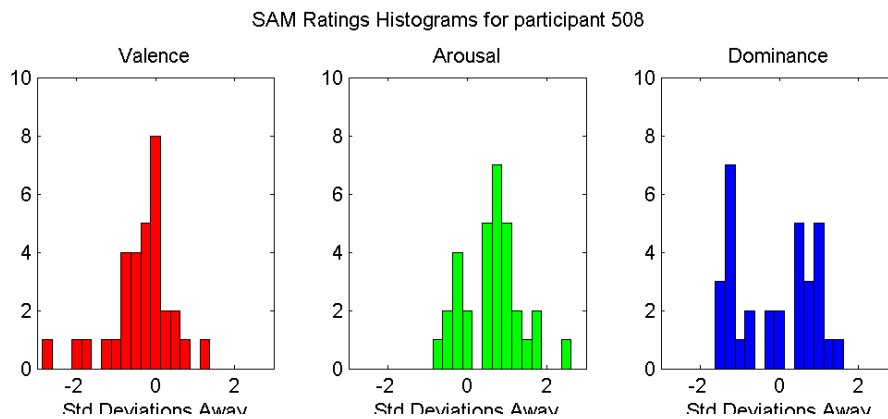

Figure 357: SAM frequency histogram for participant 8, day 5

The Dominance histogram in Figure 63 shows that participant 508 may have used the Dominance scale backwards. See Table 3 problem 1 for more information.

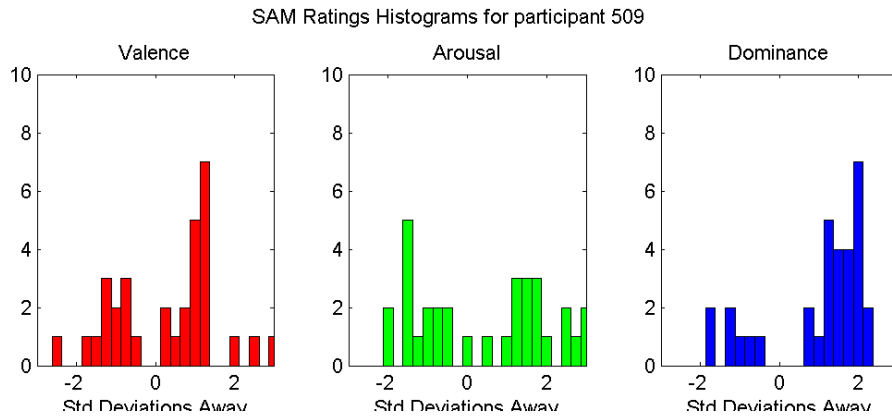

Figure 358: SAM frequency histogram for participant 9, day 5

The Valence, Arousal and Dominance for participant 509 (see Figure 64) are very poorly distributed. The results are suspect and will not be given much weight in the training process. See Table 3 problem 3 for more information.

14.3 IAPS Slide Scatter Plots

This appendix holds comparison graphs of our SAM ratings and those of reference studies. Responses that were chosen by more than one participant, in our study, are labelled x2, x3 and so on. Male responses are in blue, female in red; some slides were only shown to one gender so will lack a colour. A rectangle of matching colour is drawn to represent the area around the mean bounded by one standard deviation. The areas of one standard deviation about the mean from previous studies (P. Lang et al., 2001) are shown in grey.

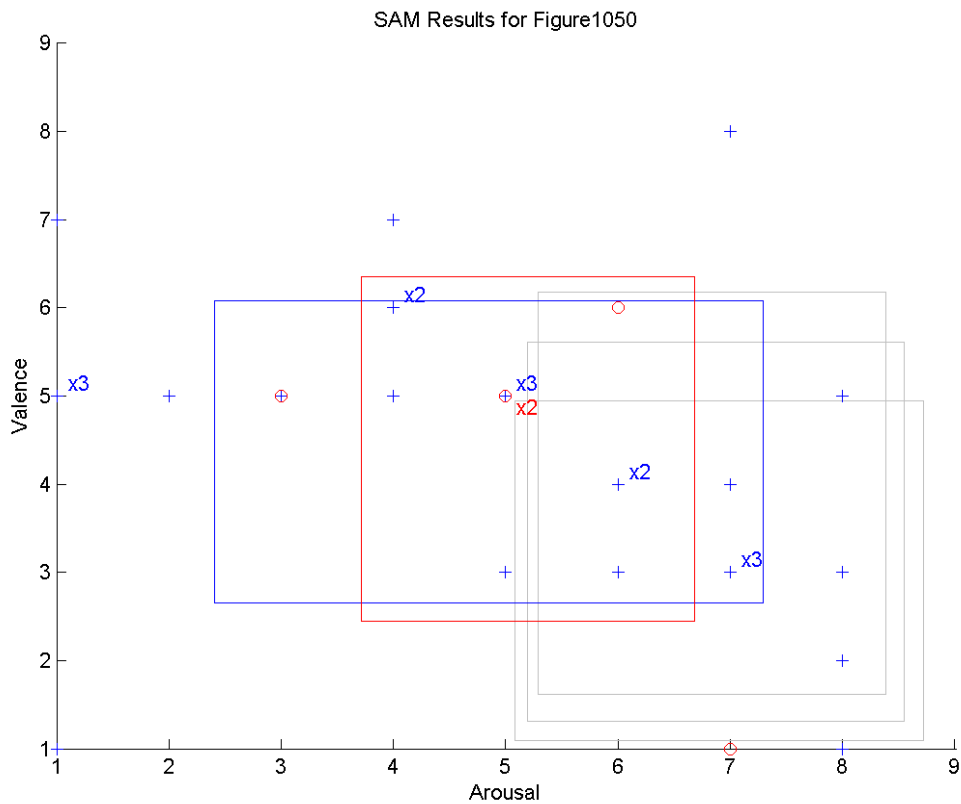

Figure 359: A plot of Arousal vs. Valence scores for slide 1050 (Snake), reference studies in grey.

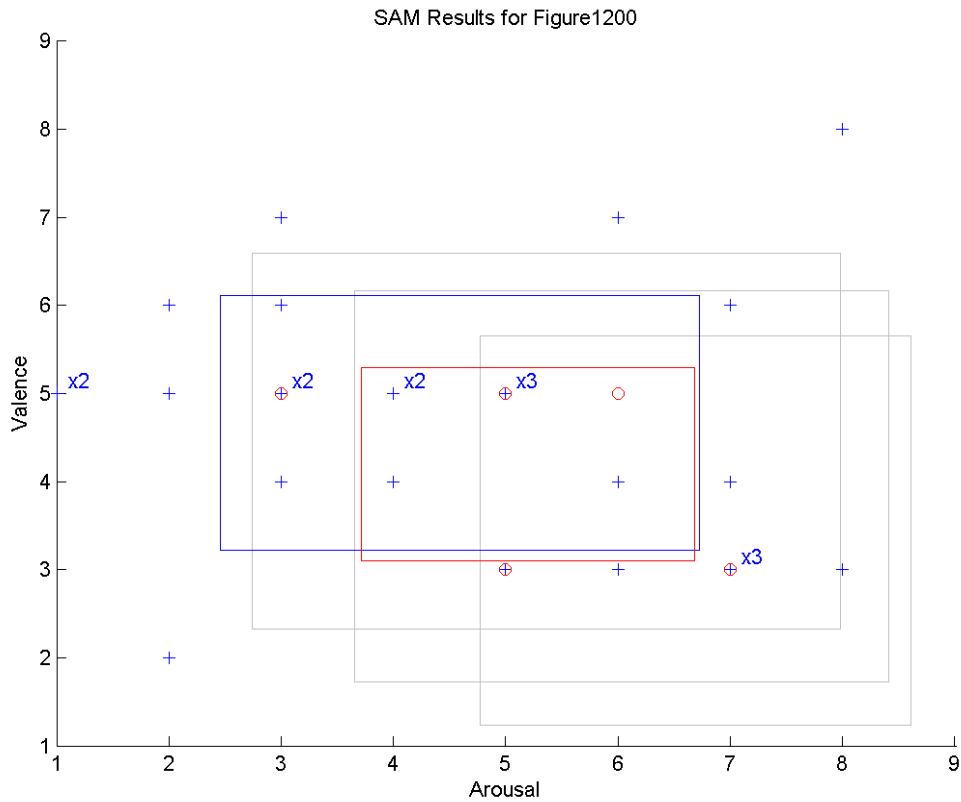

Figure 360: A plot of Arousal vs. Valence scores for slide 1200 (Big Hairy Spider), reference studies in grey.

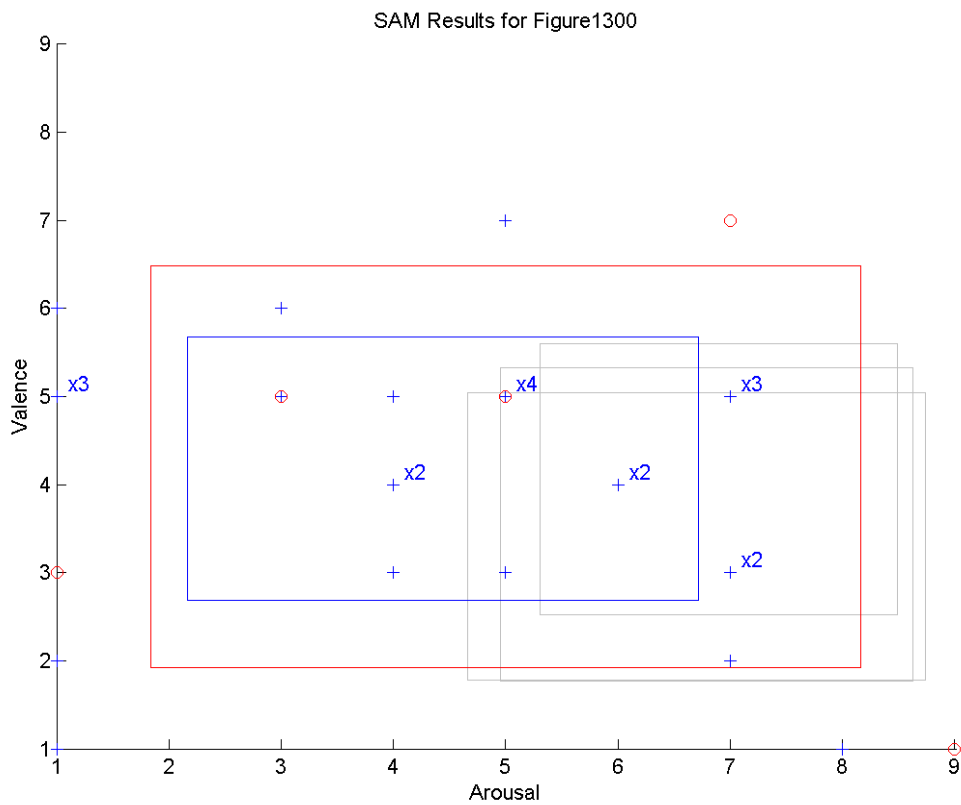

Figure 361: A plot of Arousal vs. Valence scores for slide 1300 (Angry Dog), reference studies in grey.

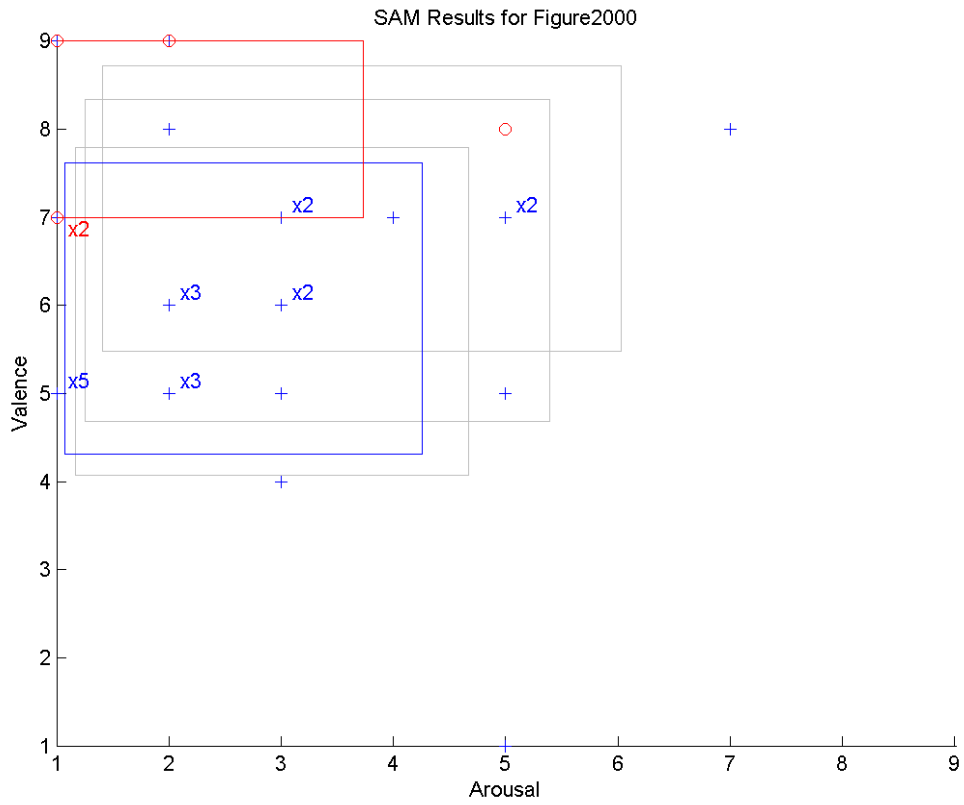

Figure 362: A plot of Arousal vs. Valence scores for slide 2000 (Smiling Male Face).

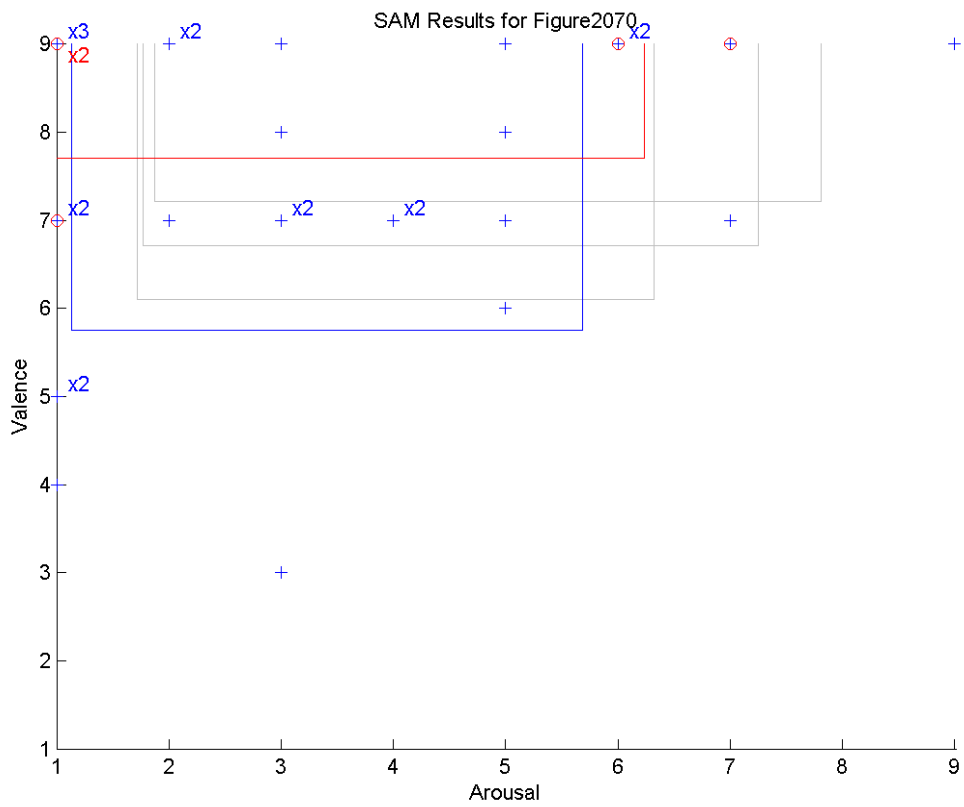

Figure 363: A plot of Arousal vs. Valence scores for slide 2070 (Human Baby).

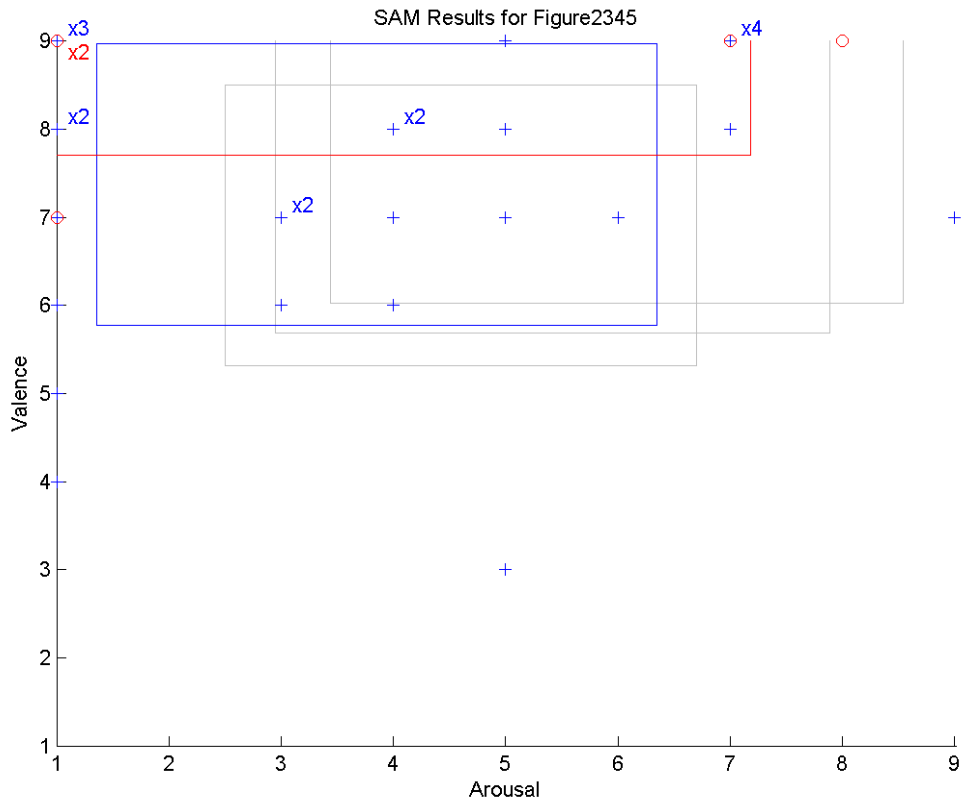

Figure 364: A plot of Arousal vs. Valence scores for slide 2345 (Kids playing).

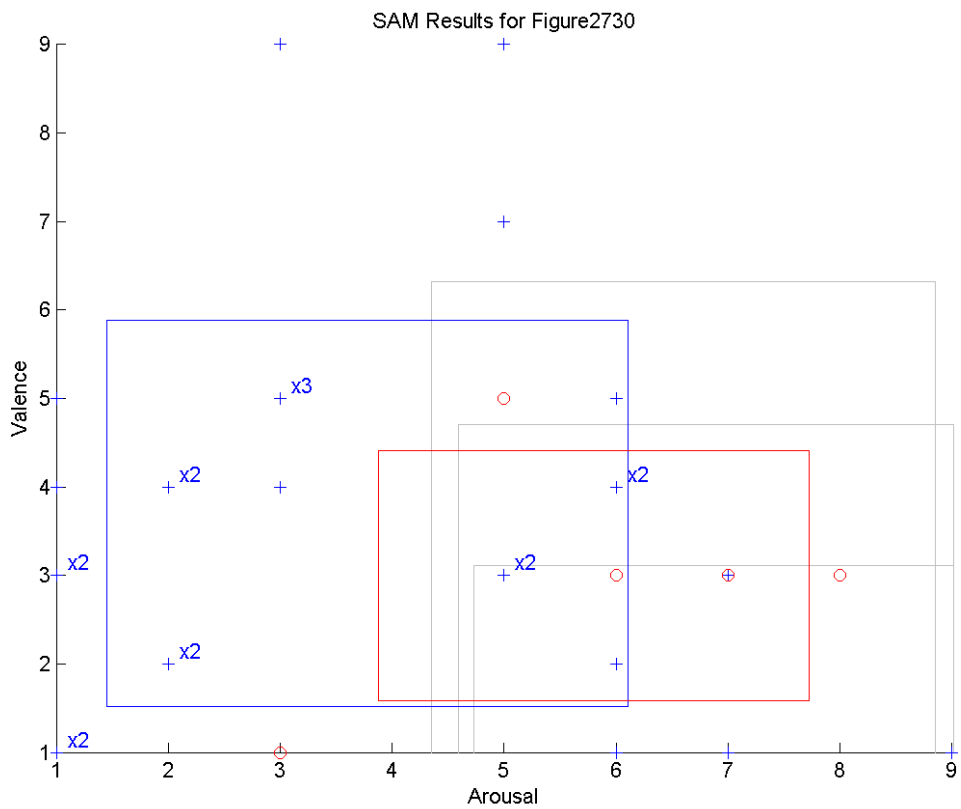

Figure 365: A plot of Arousal vs. Valence scores for slide 2730 (Boy with bison).

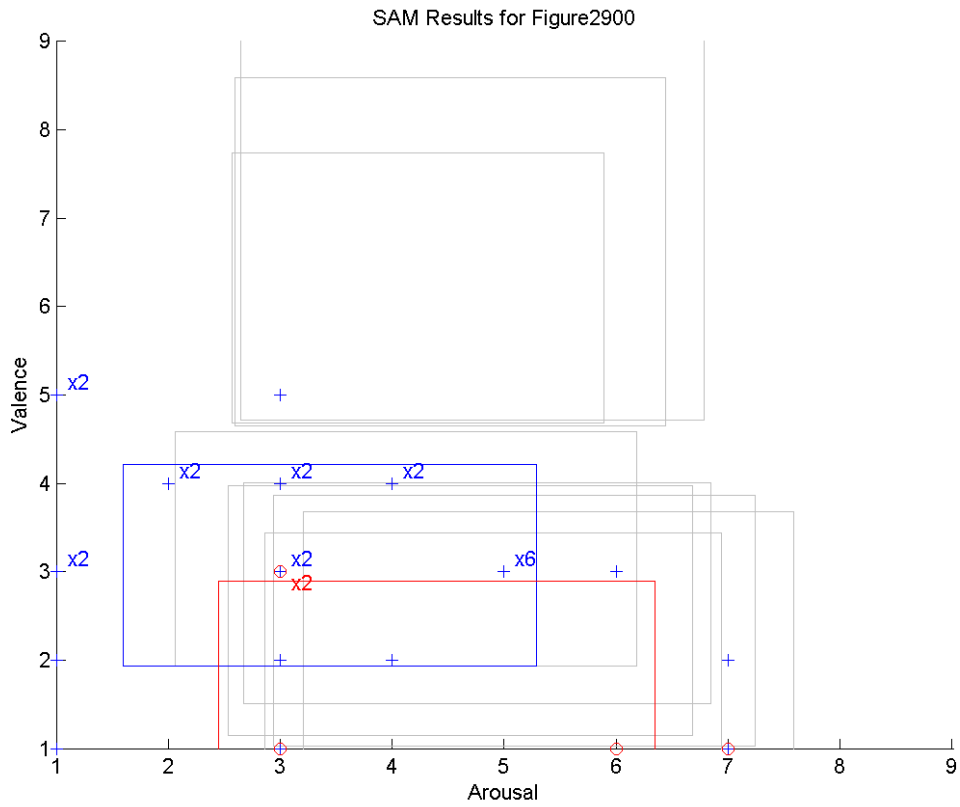

Figure 366: A plot of Arousal vs. Valence scores for slide 2900 (Boy Crying).

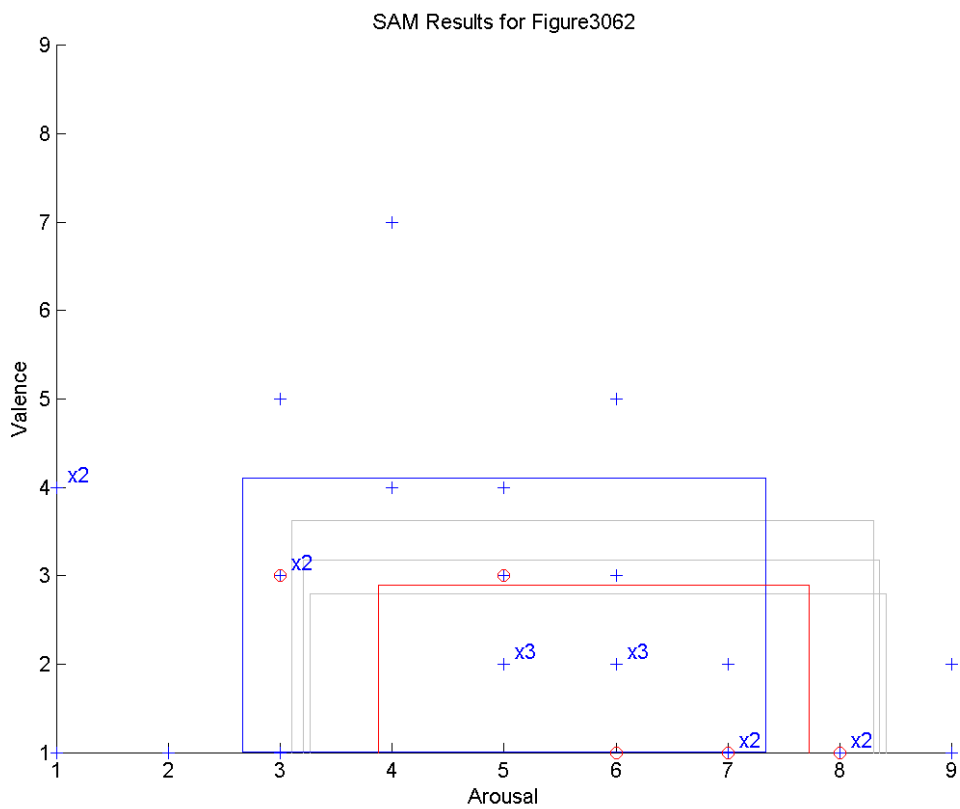

Figure 367: A plot of Arousal vs. Valence scores for slide 3062 (Abortion).

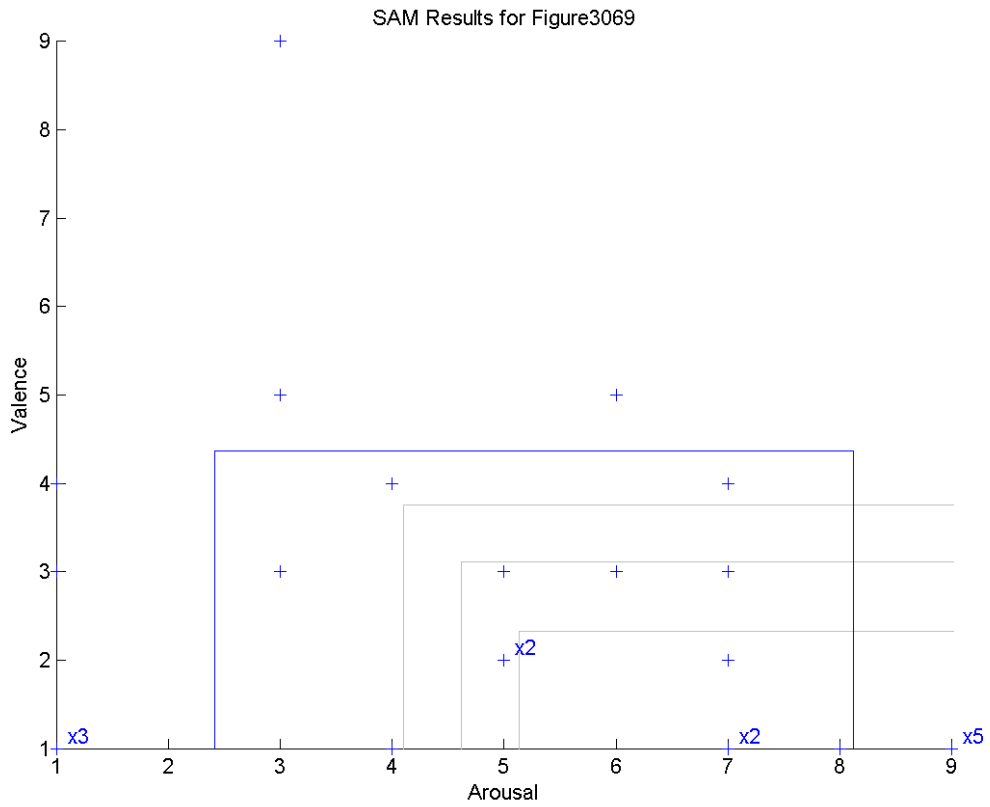

Figure 368: A plot of Arousal vs. Valence scores for slide 3069 (Girl [½ head blown away]).

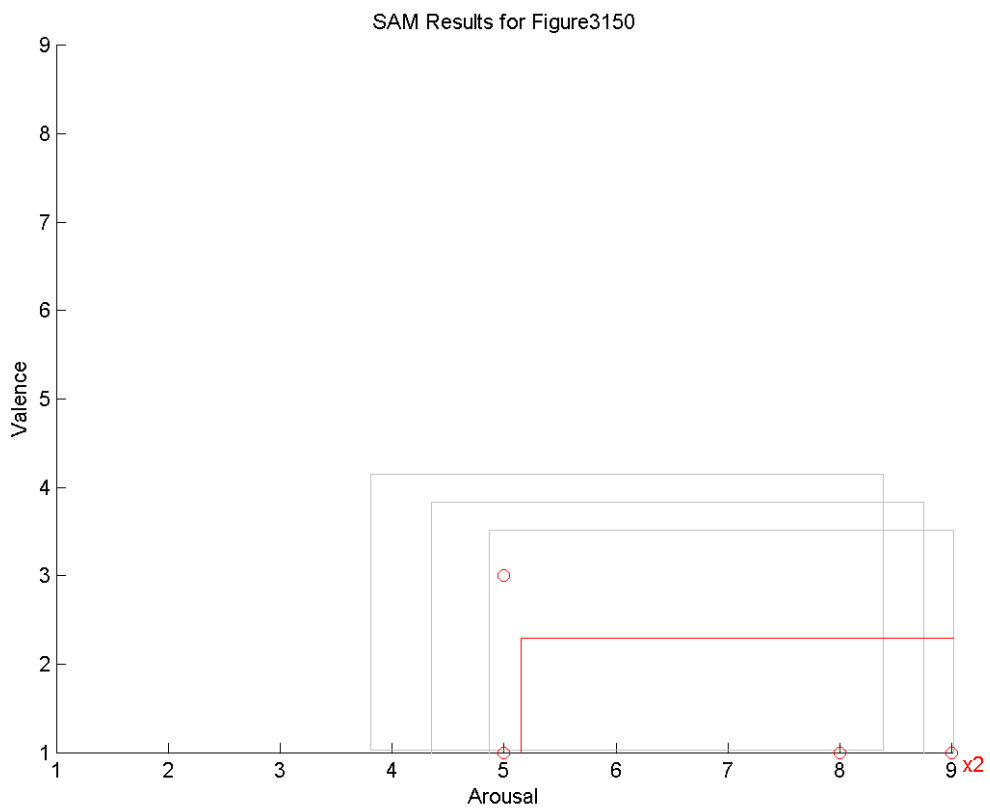

Figure 369: A plot of Arousal vs. Valence scores for slide 3150 (Hand Cut up).

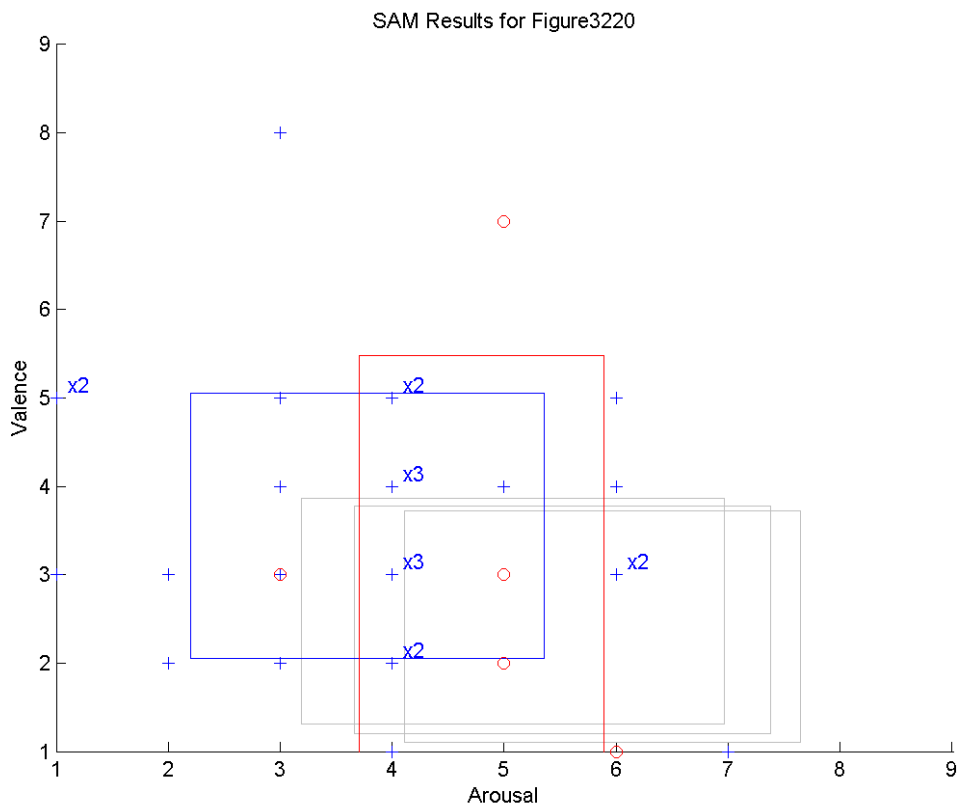

Figure 370: A plot of Arousal vs. Valence scores for slide 3220 (Male Hospital Patient).

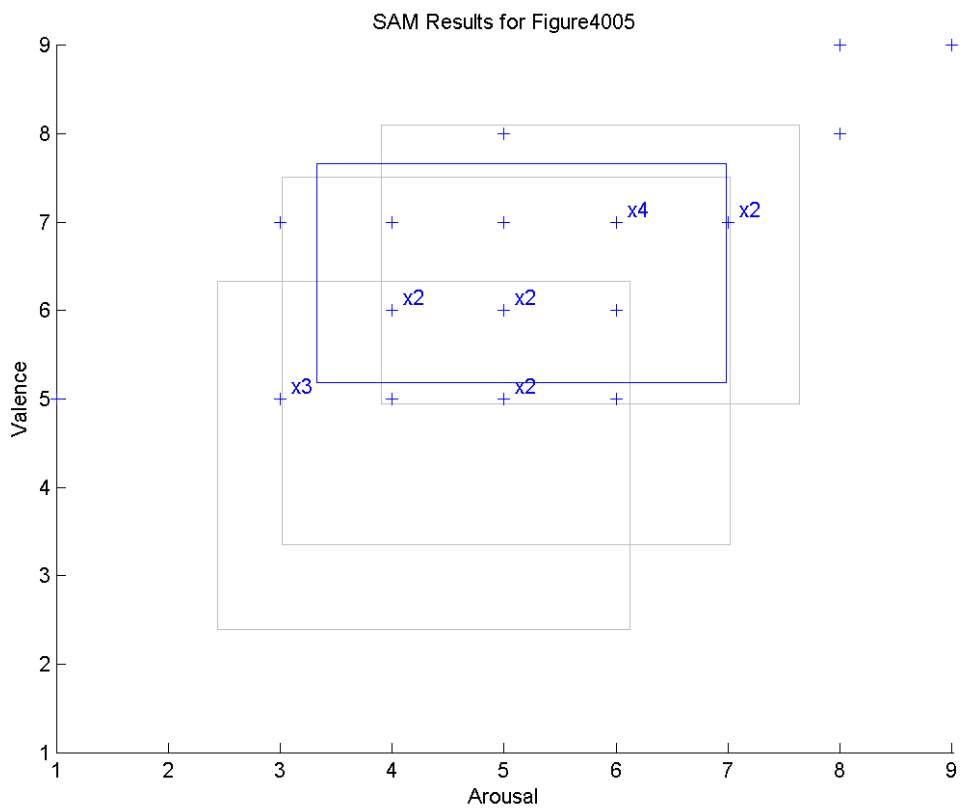

Figure 371: A plot of Arousal vs. Valence scores for slide 4005 (Female Nude [discreet]).

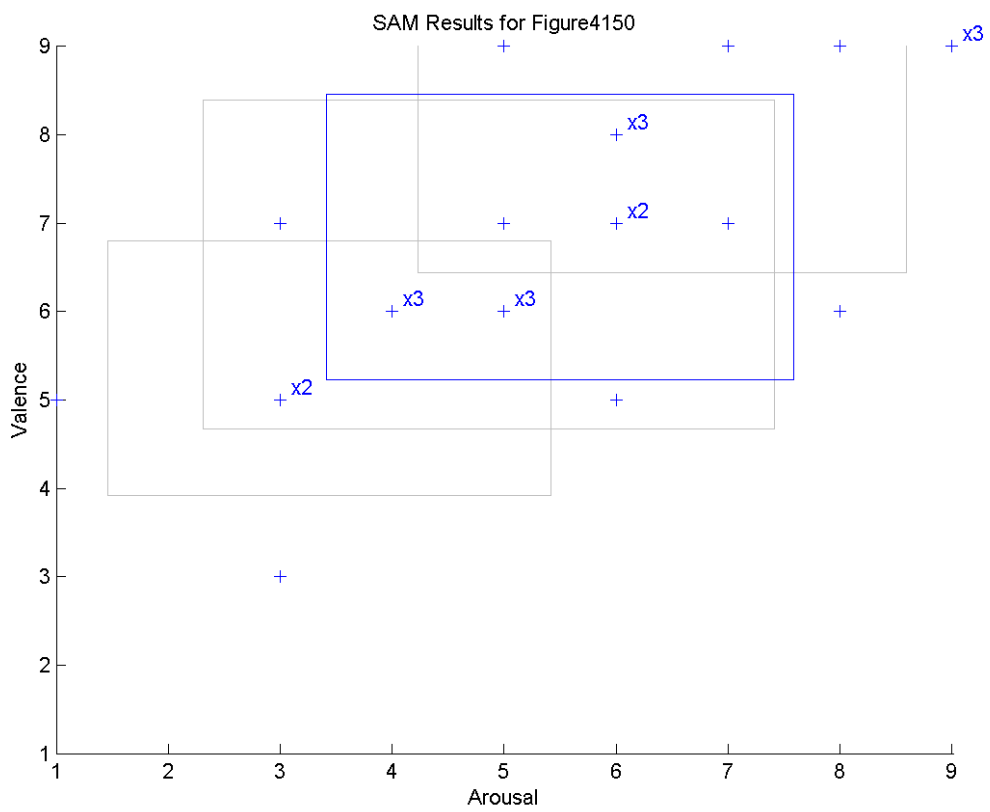

Figure 372: A plot of Arousal vs. Valence scores for slide 4150 (Female bikini).

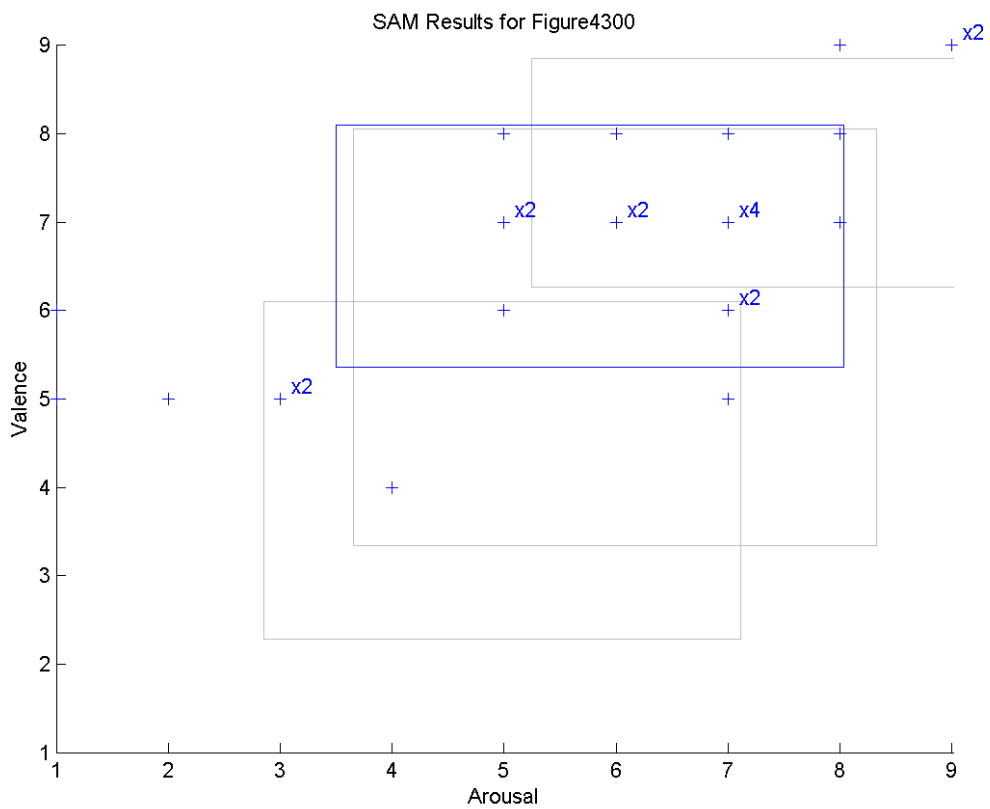

Figure 373: A plot of Arousal vs. Valence scores for slide 4300 (Female [pornographic]).

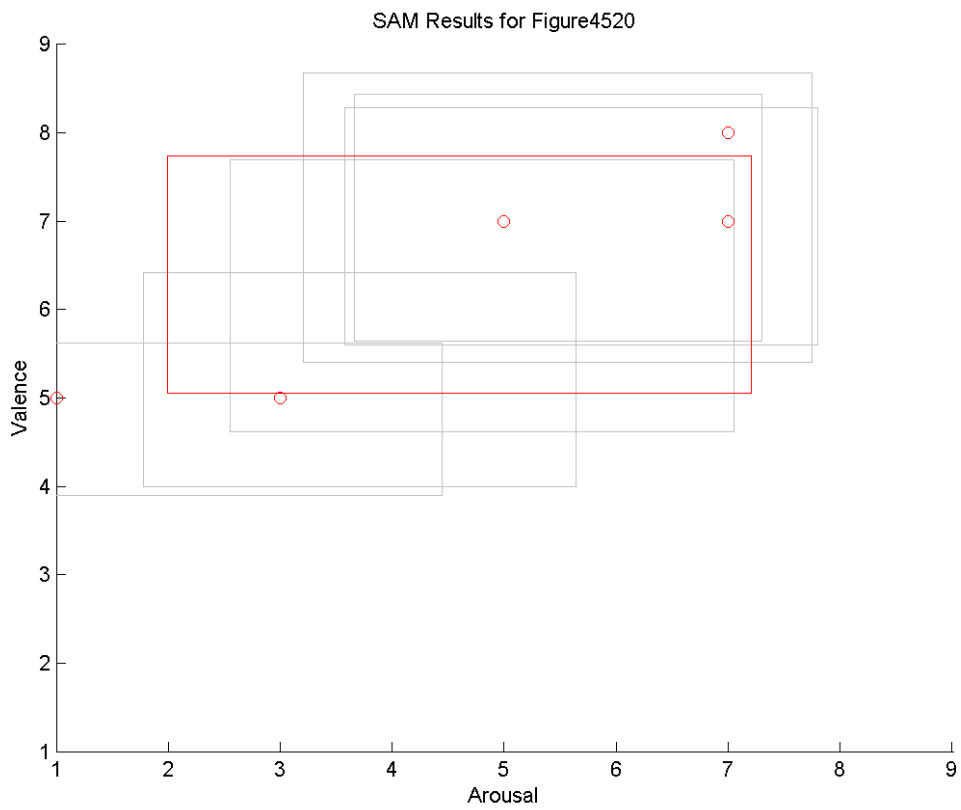

Figure 374: A plot of Arousal vs. Valence scores for slide 4520 (Male Nude [discreet]).

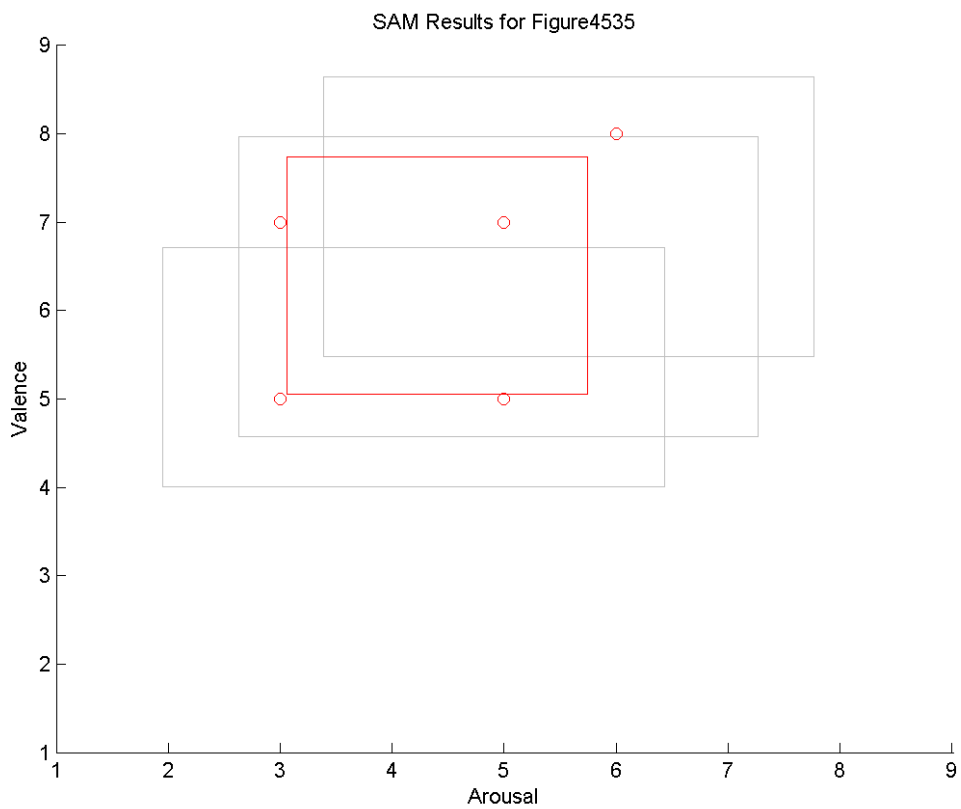

Figure 375: A plot of Arousal vs. Valence scores for slide 4535 (Male Lifting Weights).

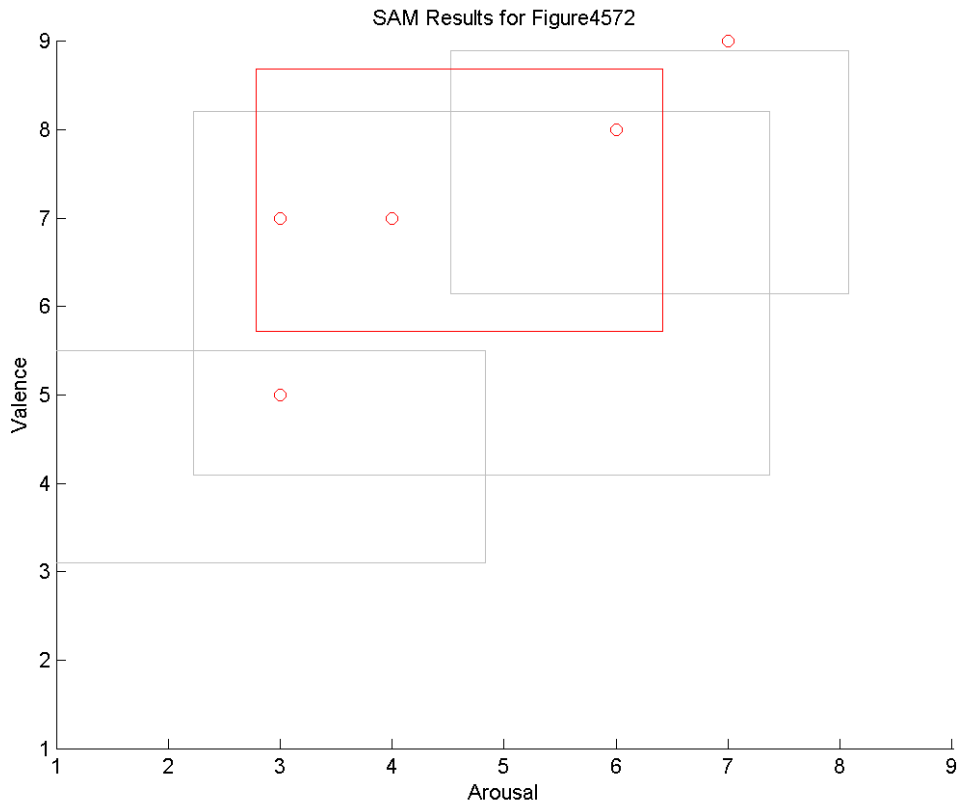

Figure 376: A plot of Arousal vs. Valence scores for slide 4572 (Handsome Fireman).

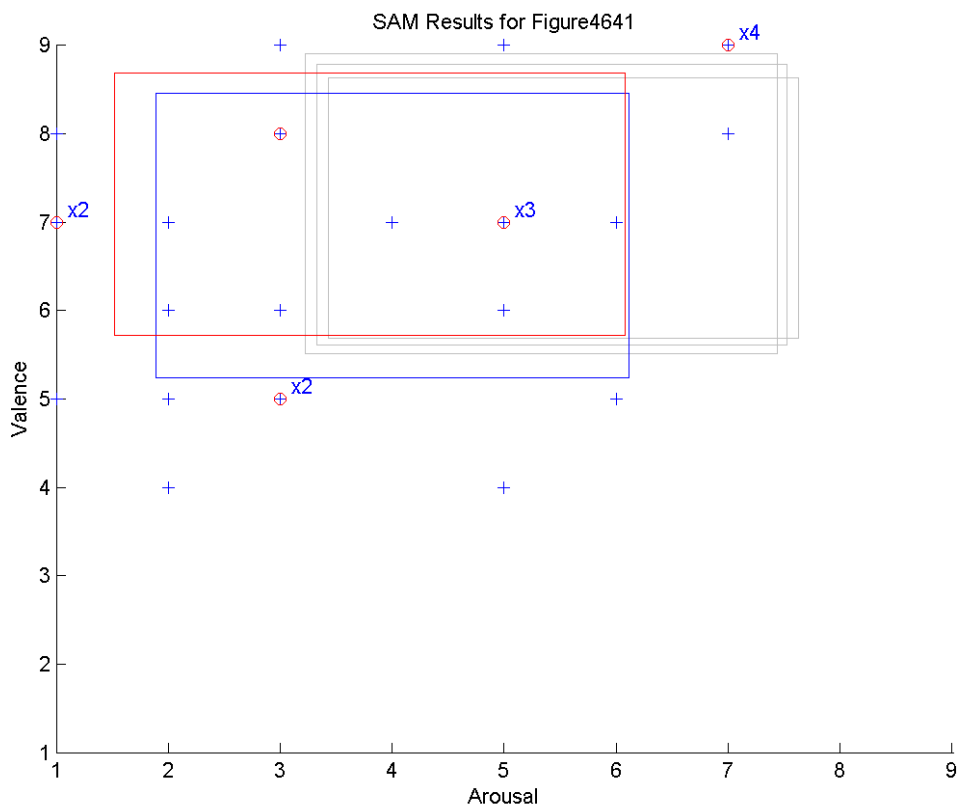

Figure 377: A plot of Arousal vs. Valence scores for slide 4641 (Couple at beach).

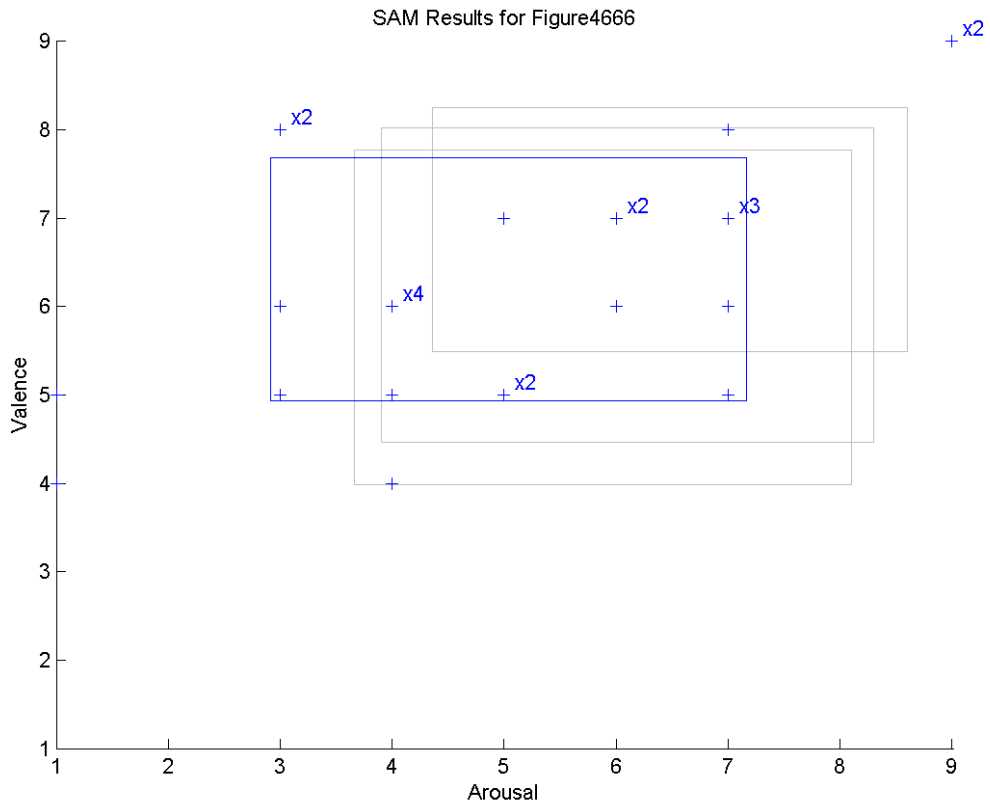

Figure 378: A plot of Arousal vs. Valence scores for slide 4666 (Couple in bed [not discreet]).

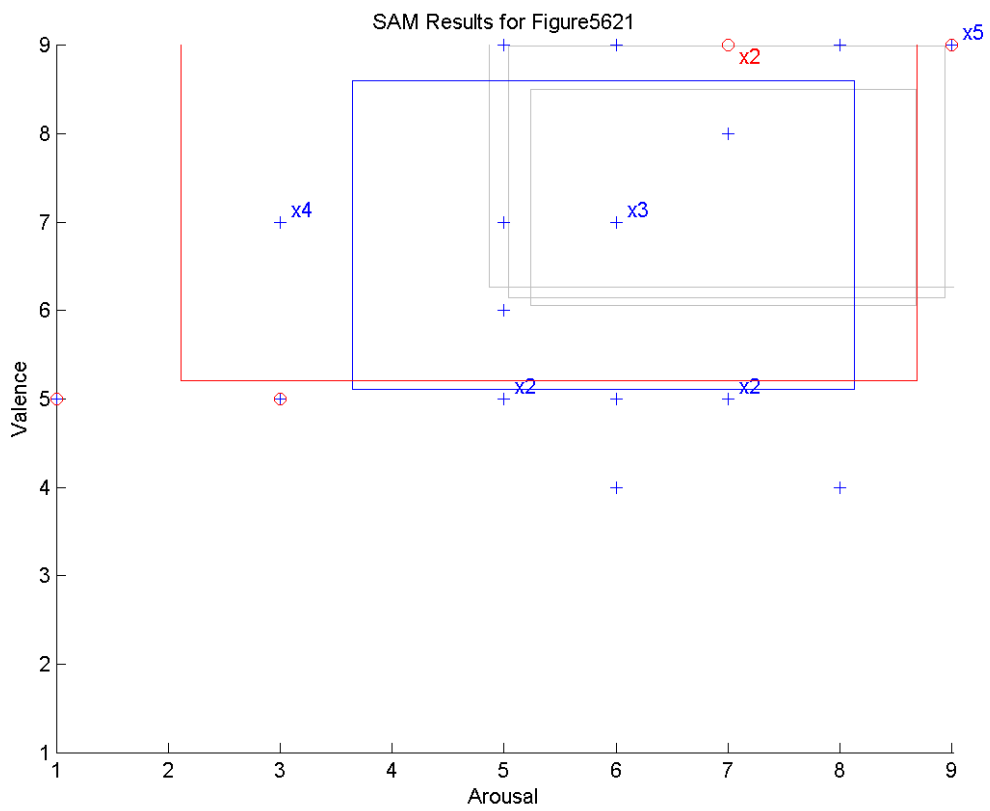

Figure 379: A plot of Arousal vs. Valence scores for slide 5621 (Skydiving formation).

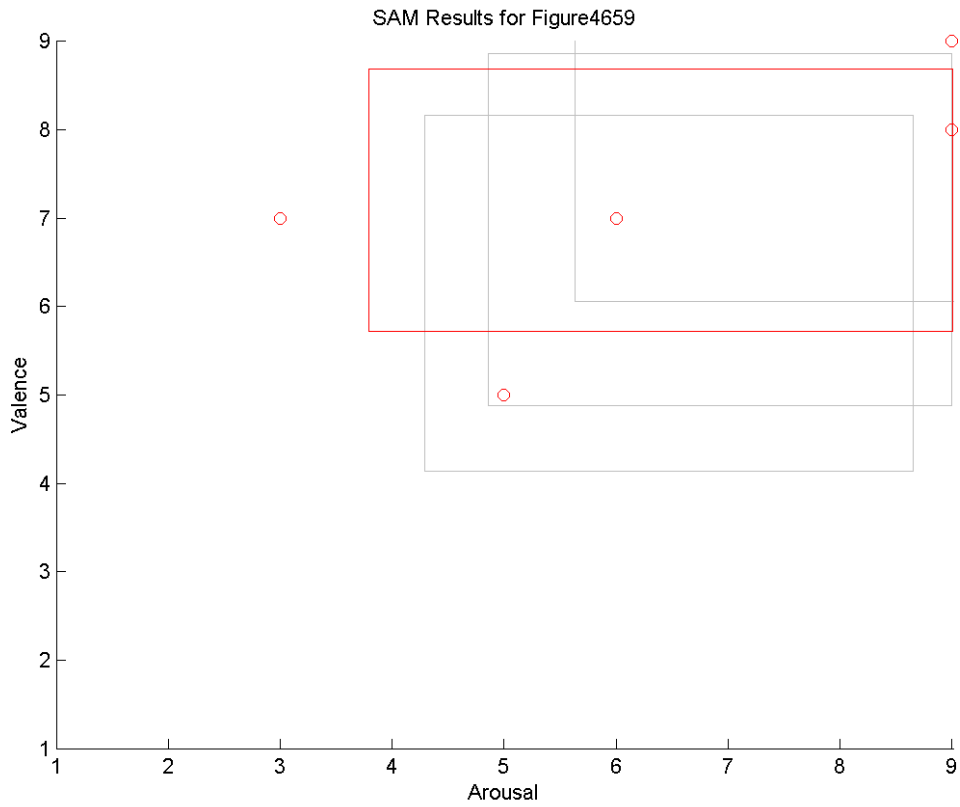

Figure 380: A plot of Arousal vs. Valence scores for slide 4659 (Couple Sex [discreet]).

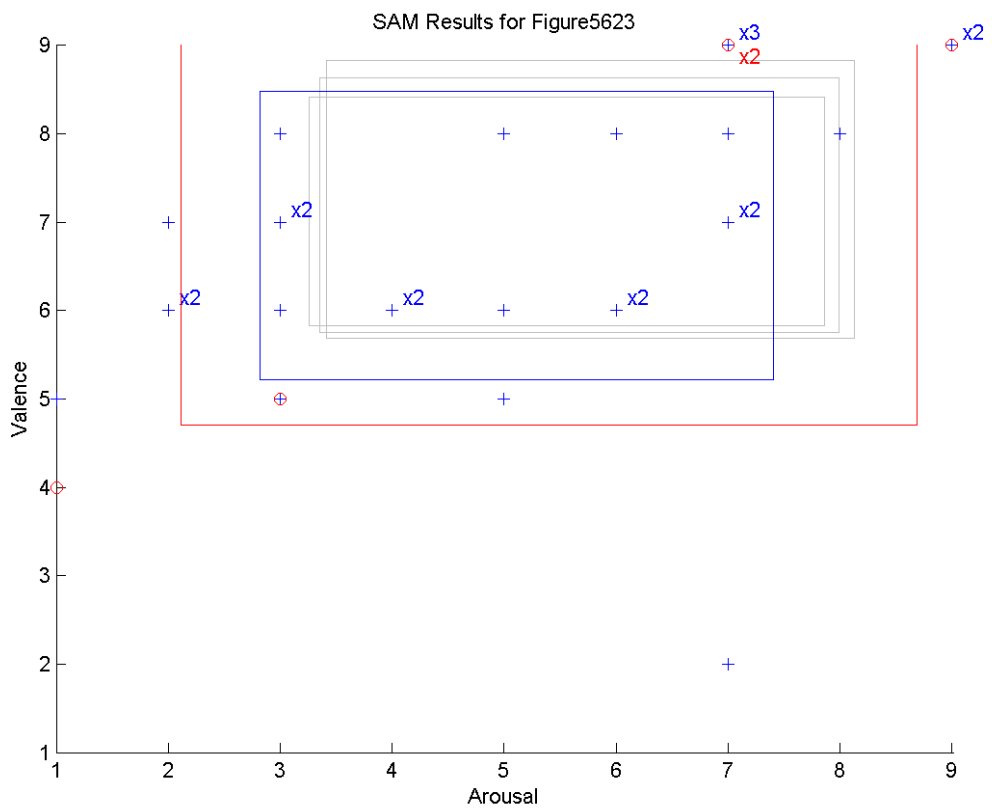

Figure 381: A plot of Arousal vs. Valence scores for slide 5623 (Extreme windsurfing).

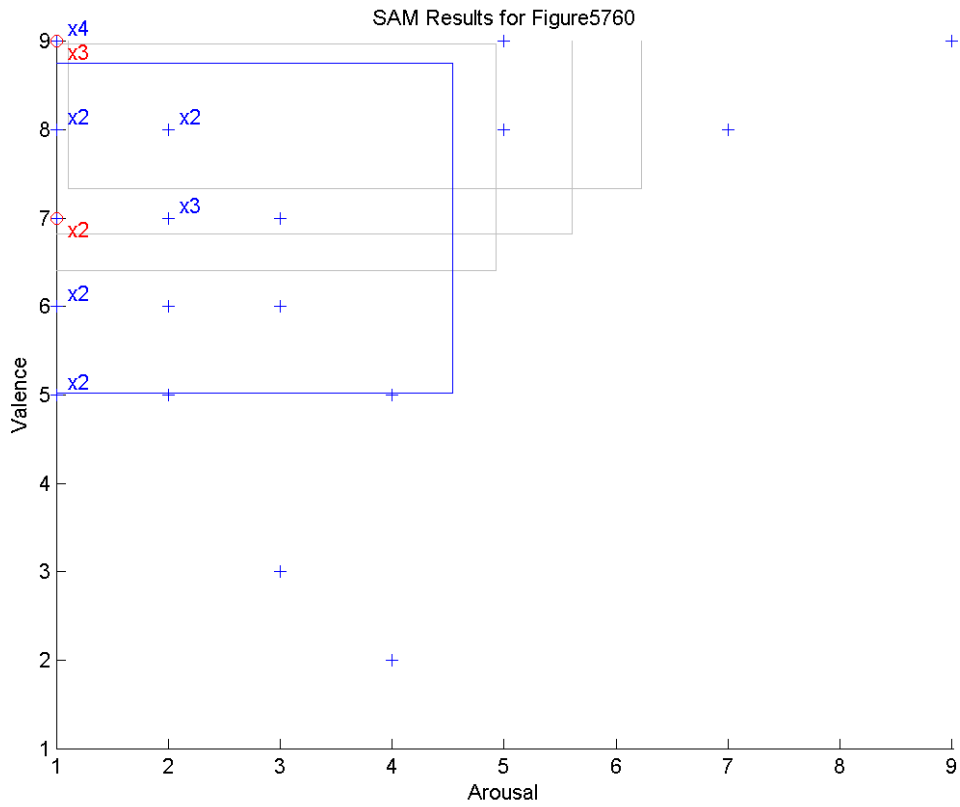

Figure 382: A plot of Arousal vs. Valence scores for slide 5760 (Flower Garden). All female Arousal = 1.

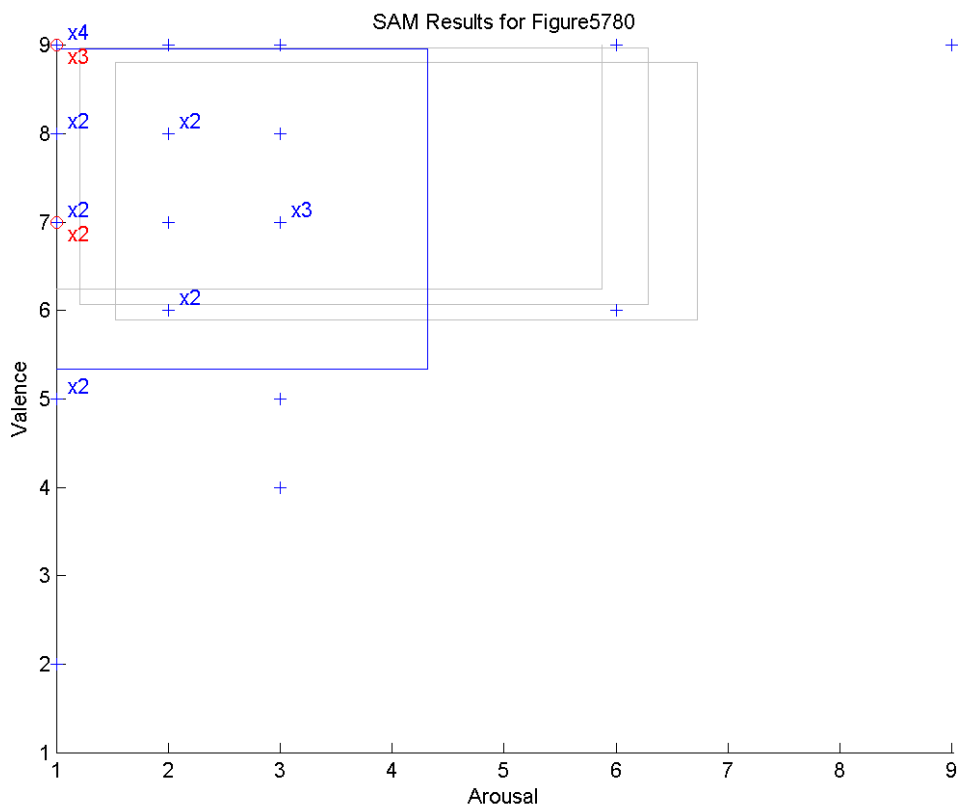

Figure 383: A plot of Arousal vs. Valence scores for slide 5780 (River). All female Arousal = 1.

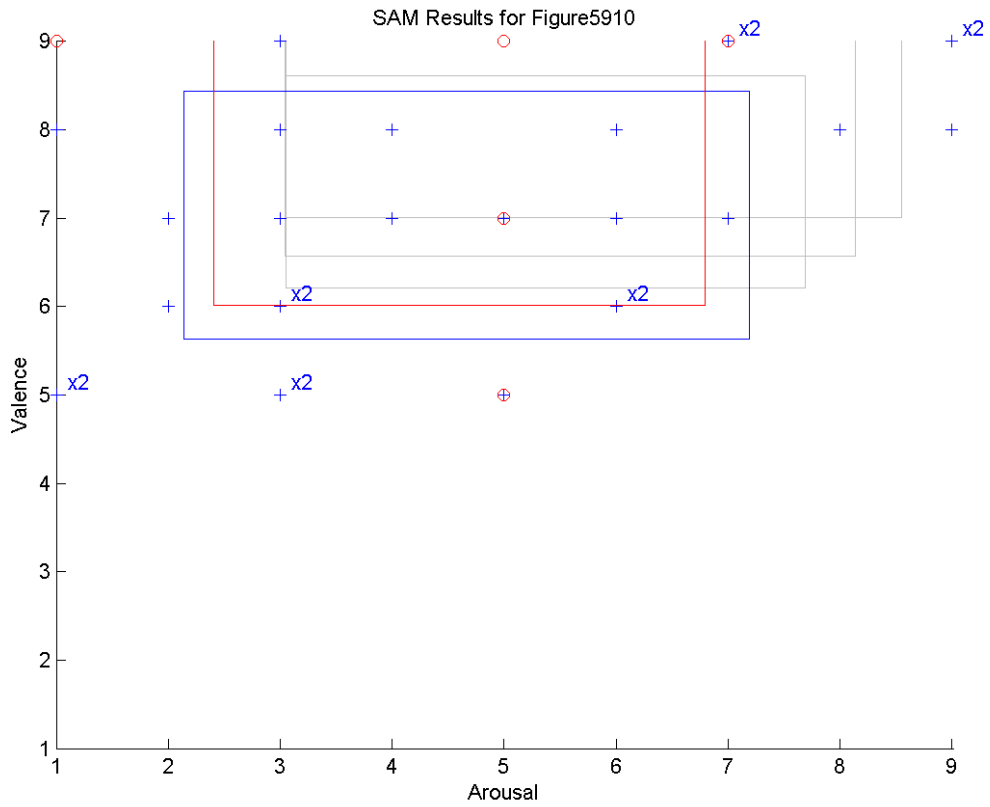

Figure 384: A plot of Arousal vs. Valence scores for slide 5910 (Fireworks [over city]).

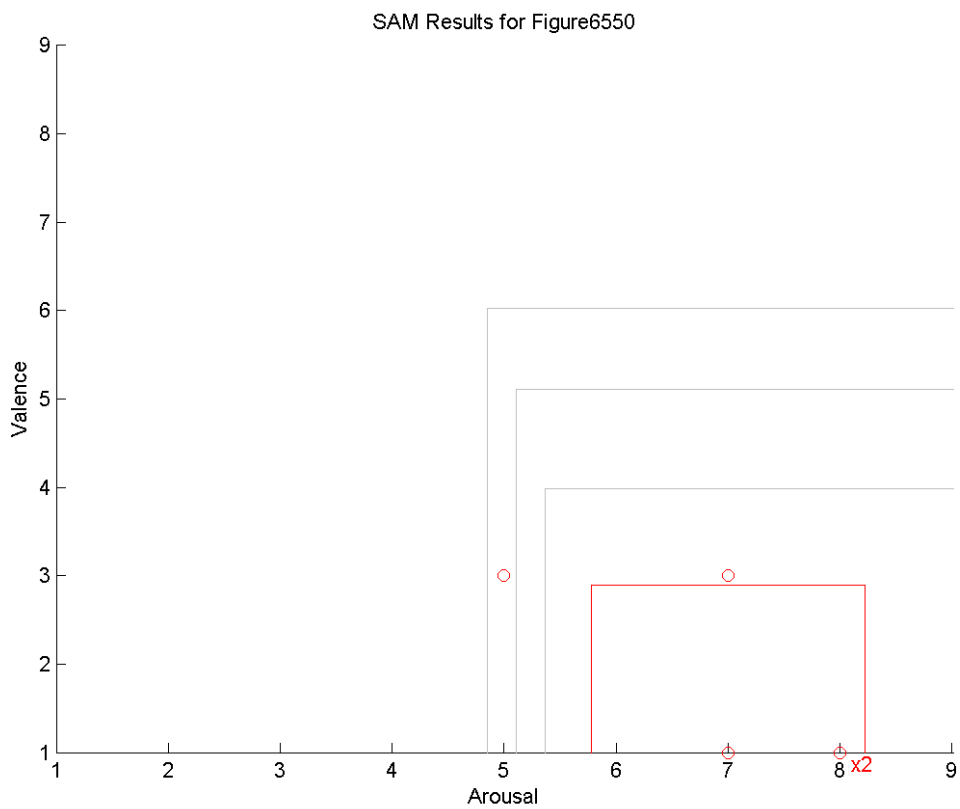

Figure 385: A plot of Arousal vs. Valence scores for slide 6550 (Violent Scene).

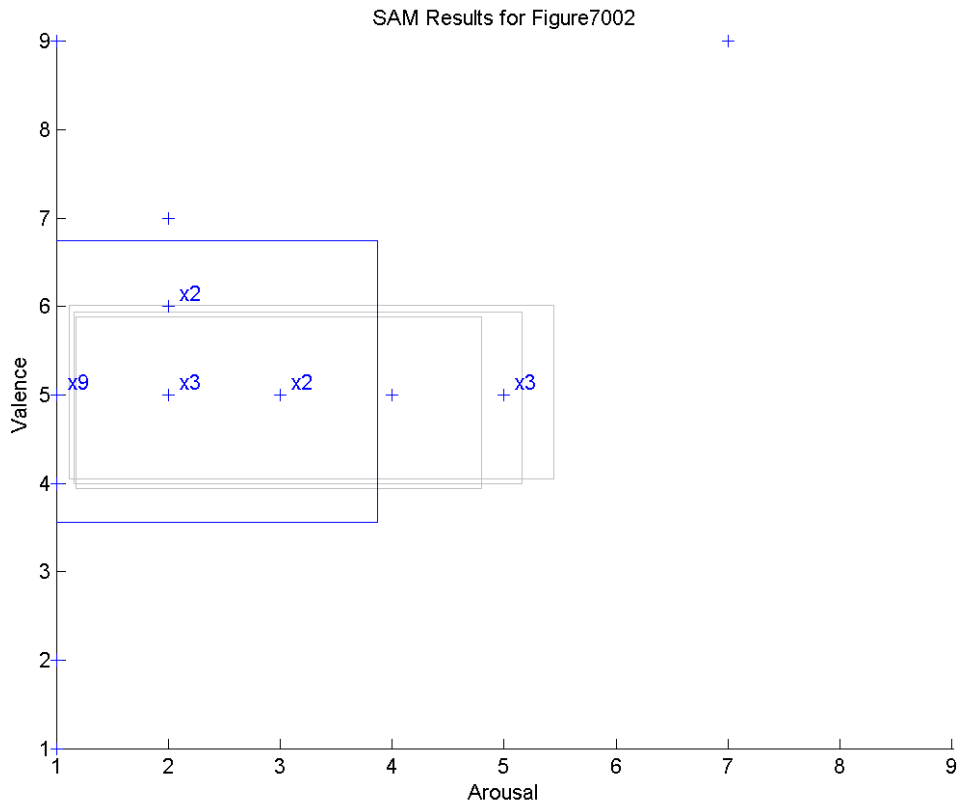

Figure 386: A plot of Arousal vs. Valence scores for slide 7002 (Towel).

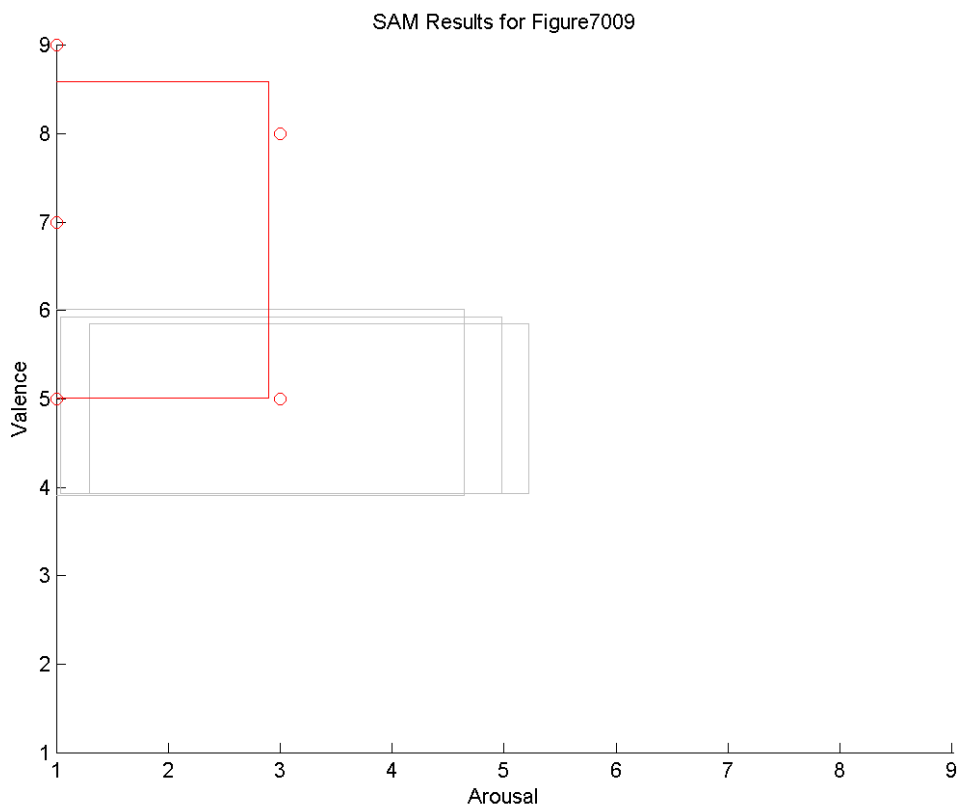

Figure 387: A plot of Arousal vs. Valence scores for slide 7009 (Mug).

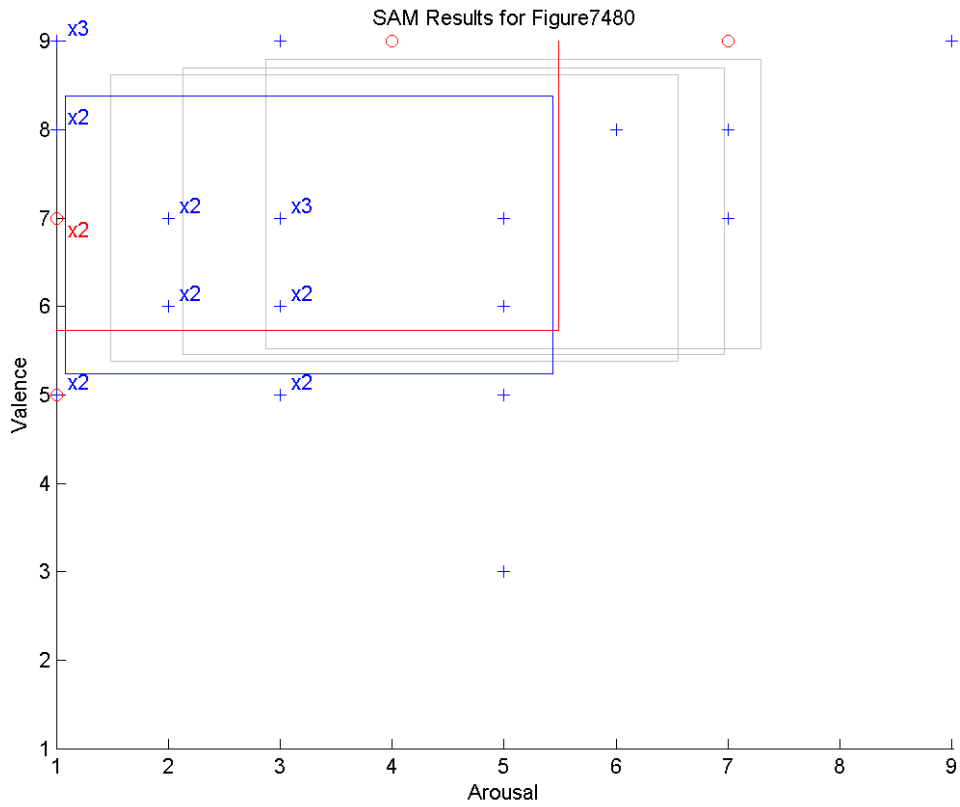

Figure 388: A plot of Arousal vs. Valence scores for slide 7480 (Spaghetti).

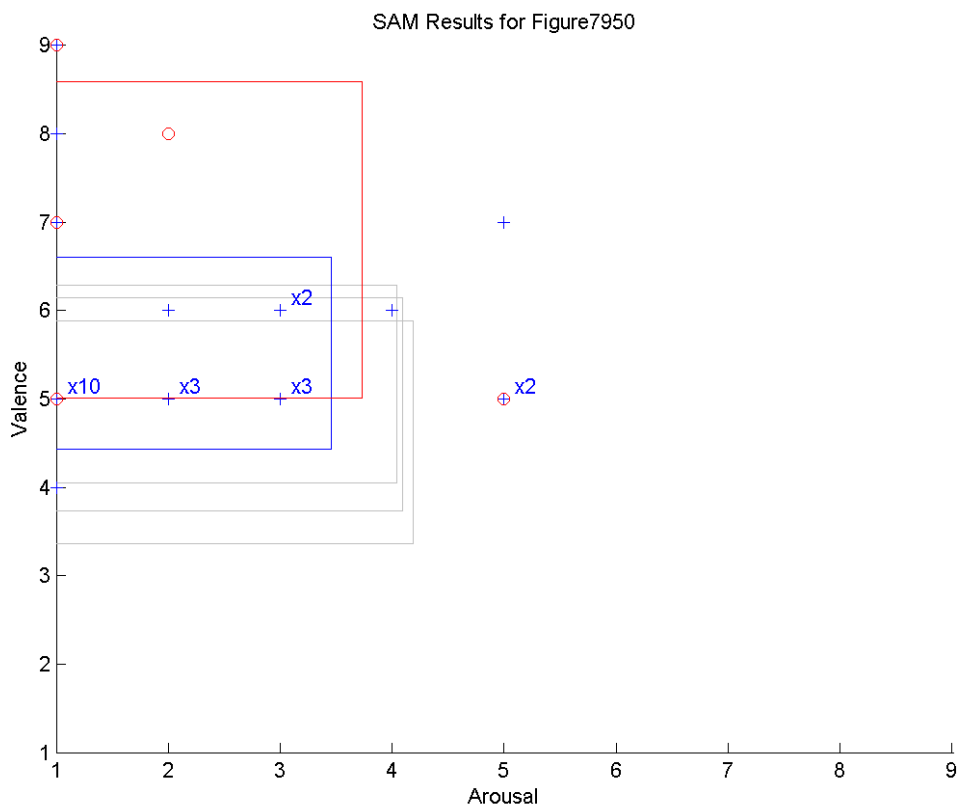

Figure 389: A plot of Arousal vs. Valence scores for slide 7950 (Tissues).

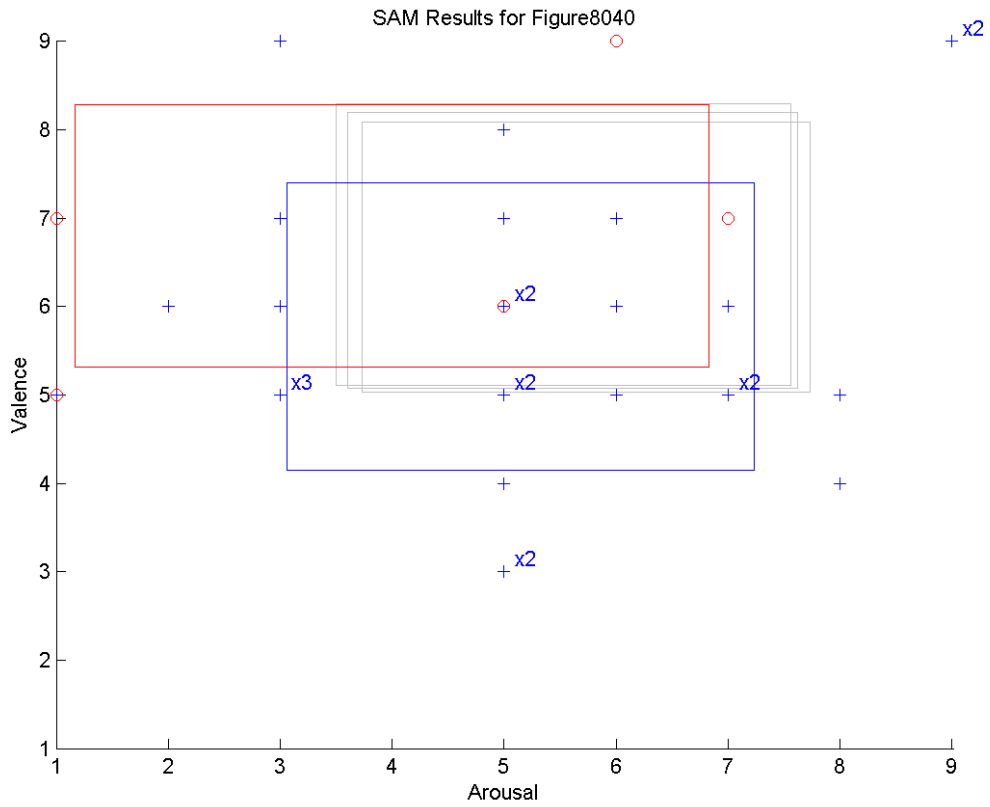

Figure 390: A plot of Arousal vs. Valence scores for slide 8040 (High diver).

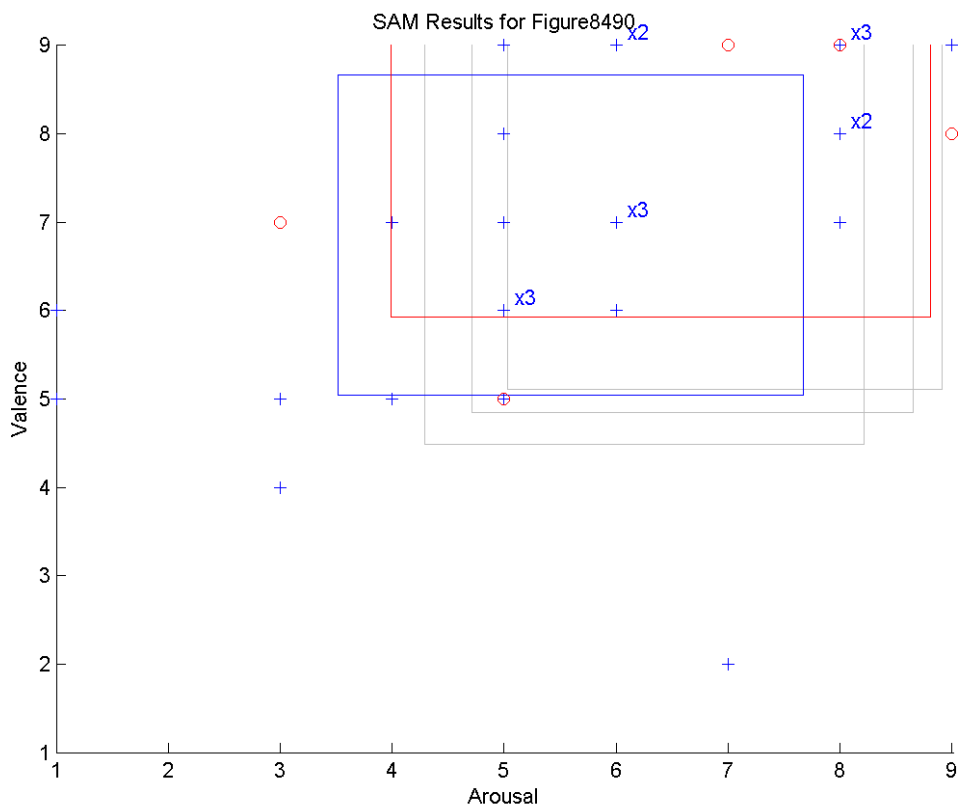

Figure 391: A plot of Arousal vs. Valence scores for slide 8490 (People in a roller coaster).

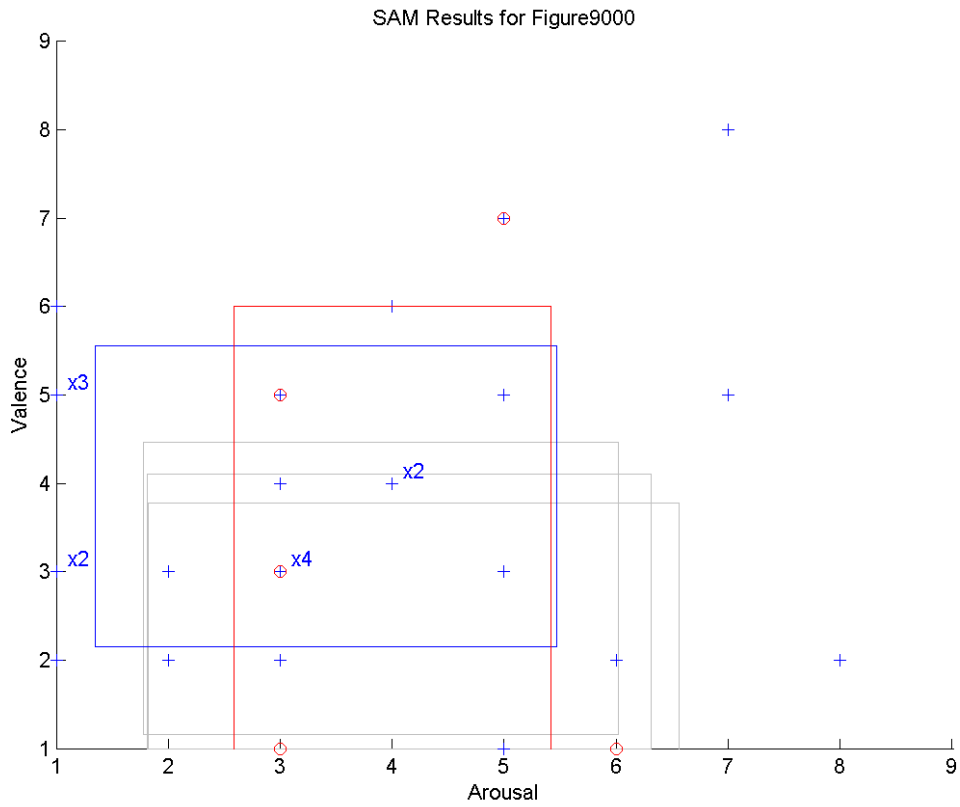

Figure 392: A plot of Arousal vs. Valence scores for slide 9000 (Graveyard).

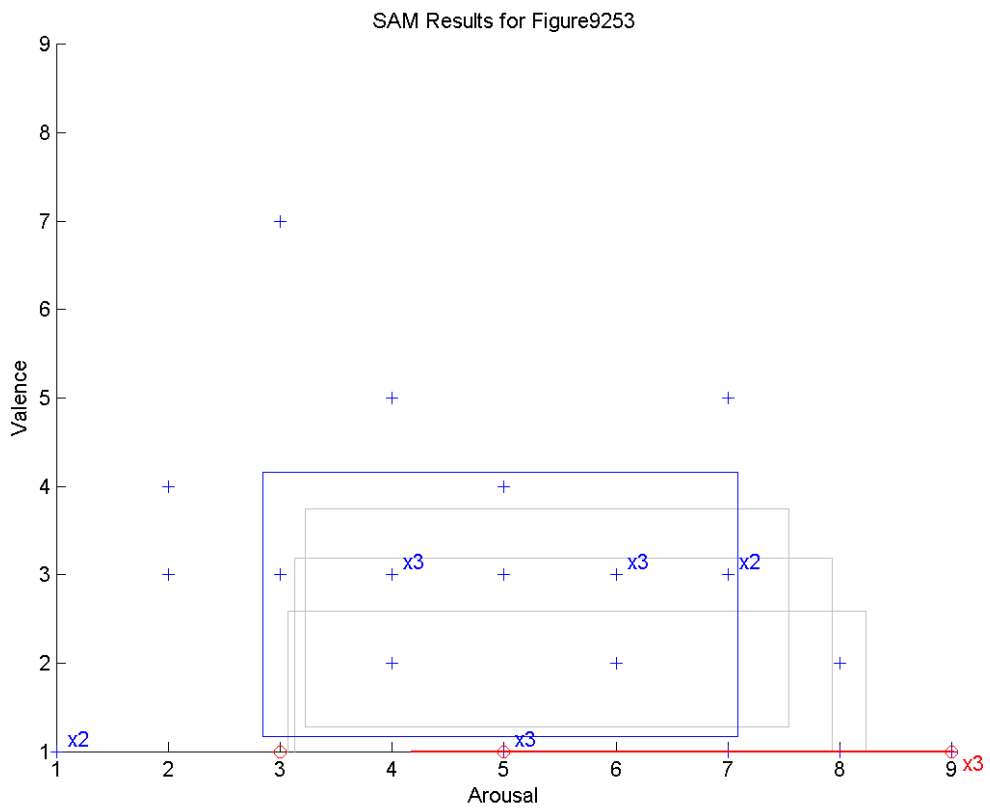

Figure 393: A plot of Arousal vs. Valence scores for slide 9253 (Execution [young lady]).

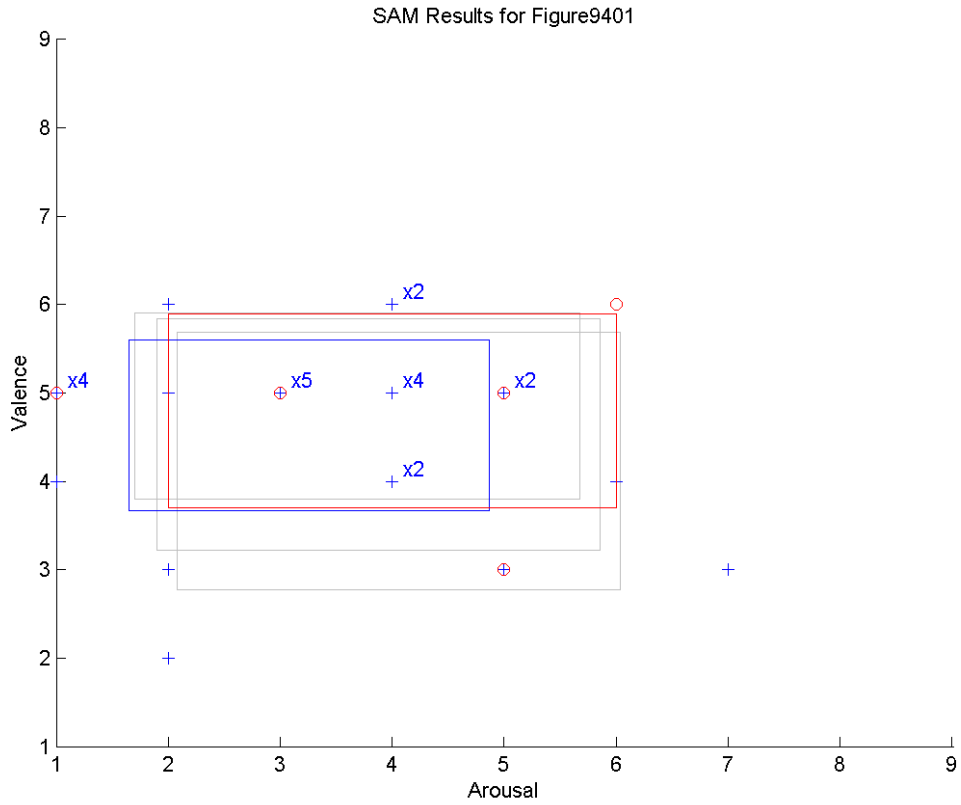

Figure 394: A plot of Arousal vs. Valence scores for slide 9401 (Knives [subliminal words]).

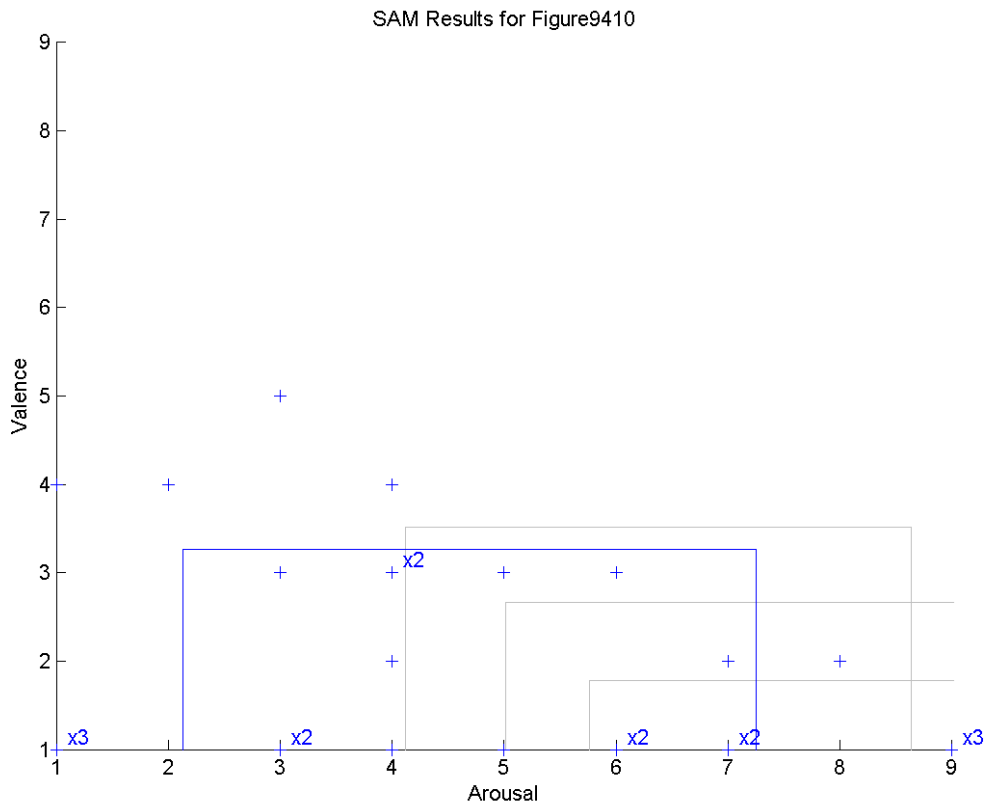

Figure 395: A plot of Arousal vs. Valence scores for slide 9410 (Warzone [parent with child]).

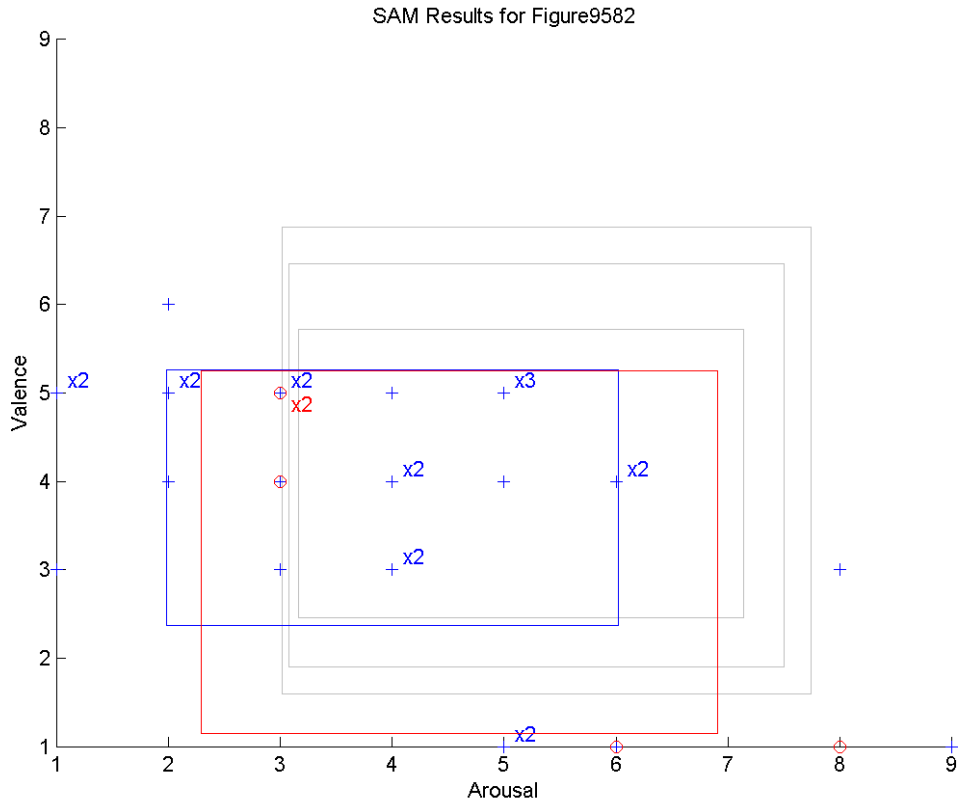

Figure 396: A plot of Arousal vs. Valence scores for slide 9582 (Dental exam).

14.4 ECG "NARF" Compensations For all Intervals of the Typical Waveform

The next five pages contain tables for the NARF transform as a polynomial function for inter and intra ECG feature intervals.

Rest of page left blank intentionally.

Table 27: Intra-beat NARF transform

Interval	$y = ax^2 + bx + c$		
	a	b	c
P_finish to t_onset	0.1350	-0.2082	0.1450
P_finish to t_peak	-0.0359	0.0225	0.0777
P_finish to t_peak	-0.1855	1.2337	-0.1667
P_finish to t_finish	-0.1036	1.0773	-0.1382
P_finish to t_peak	-0.1855	1.2270	-0.1837
P_finish to t_finish	0.0451	0.7290	-0.2030
P_finish to t_onset	-0.0721	0.9452	-0.1598
P_finish to t_peak	0.0217	0.7809	-0.1595
P_onset to t_finish	-0.1051	0.1924	-0.0229
P_onset to t_peak	-0.0498	0.0930	-0.0108
P_onset to t_onset	0.0293	-0.0147	0.1216
P_onset to t_peak	-0.0892	0.1496	0.0712
P_onset to t_peak	-0.0804	1.0413	-0.1437
P_onset to t_finish	0.0014	0.8850	-0.1153
P_onset to t_peak	-0.0477	0.9787	-0.1369
P_onset to t_finish	0.1396	0.5528	-0.1856
P_onset to t_onset	0.0224	0.7690	-0.1424
P_onset to t_peak	0.1162	0.6047	-0.1421
P_peak to t_finish	-0.0553	0.0994	-0.0121
P_peak to t_onset	0.0795	-0.1084	0.1327
P_peak to t_peak	-0.0595	0.0806	0.0766
P_peak to t_peak	-0.1302	1.1343	-0.1545
P_peak to t_finish	-0.0482	0.9778	-0.1261
P_peak to t_peak	-0.1209	1.1109	-0.1642
P_peak to t_finish	0.0947	0.6382	-0.1938
P_peak to t_onset	-0.0225	0.8544	-0.1507
P_peak to t_peak	0.0714	0.6901	-0.1503
q_onset to t_peak	-0.0336	0.0539	-0.0064
q_onset to t_peak	-0.1559	1.1820	-0.0723
q_onset to t_finish	-0.0682	1.0163	-0.0404
q_onset to t_peak	-0.1258	1.1270	-0.0695
q_onset to t_finish	0.1888	0.5036	-0.0511
q_onset to t_onset	0.0721	0.7192	-0.0077
q_onset to t_peak	0.1673	0.5525	-0.0065
q_peak to t_peak	-0.1606	1.1215	-0.0173
q_peak to t_finish	-0.1210	1.0345	-0.0155
q_peak to t_peak	-0.1179	1.0751	-0.0272
q_peak to t_finish	0.1301	0.5627	-0.0518
q_peak to t_onset	0.0211	0.7564	0.0011
q_peak to t_peak	0.0936	0.6280	-0.0119
r_peak to t_finish	-0.0915	0.1720	-0.0343
r_peak to t_peak	-0.0612	0.1117	-0.0259
r_peak to t_finish	-0.2257	0.5029	0.0362
r_peak to t_onset	-0.1111	0.2909	-0.0087
r_peak to t_peak	-0.2060	0.4571	-0.0097
s_finish to t_finish	-0.1440	0.3456	0.0655
s_finish to t_onset	-0.0295	0.1336	0.0206
s_finish to t_peak	-0.1243	0.2998	0.0196
s_peak to t_finish	-0.0122	0.0213	0.0133
s_peak to t_finish	-0.1961	0.4394	0.0450
s_peak to t_onset	-0.0702	0.2167	0.0000
s_peak to t_peak	-0.1622	0.3737	0.0050
t_onset to t_finish	-0.1146	0.2120	0.0449
t_onset to t_peak	-0.0949	0.1661	-0.0011
t_peak to t_finish	-0.0197	0.0458	0.0459

Table 28: Inter-beat NARF transform

Interval	$y = ax^2 + bx + c$		
	a	b	c
intra beet P_finish to t_finish	-0.1326	1.1560	-0.0357
intra beet P_finish to t_onset	-0.0348	0.9752	-0.0174
intra beet P_finish to t_peak	-0.0856	1.0701	-0.0290
intra beet P_finish to t_onset	-0.1587	1.1878	0.0304
intra beet P_finish to t_peak	-0.1378	1.0713	0.1078
intra beet P_finish to t_peak	0.1042	-0.1520	0.1540
intra beet P_finish to t_finish	0.0109	0.0234	0.1181
intra beet P_finish to t_peak	0.1033	-0.1318	0.1614
intra beet P_finish to t_finish	-0.1310	0.3669	0.1840
intra beet P_finish to t_onset	0.0003	0.1270	0.1501
intra beet P_finish to t_peak	-0.1070	0.3138	0.1410
intra beet P_onset to t_finish	-0.2352	1.3480	-0.0595
intra beet P_onset to t_onset	-0.1390	1.1695	-0.0420
intra beet P_onset to t_peak	-0.1863	1.2594	-0.0518
intra beet P_onset to t_onset	-0.2608	1.3776	0.0080
intra beet P_onset to t_peak	-0.1445	1.1307	0.1261
intra beet P_onset to t_peak	0.0111	0.0239	0.1369
intra beet P_onset to t_finish	-0.0822	0.1992	0.1010
intra beet P_onset to t_peak	-0.0183	0.0934	0.1228
intra beet P_onset to t_finish	-0.2145	0.5276	0.1724
intra beet P_onset to t_onset	-0.0831	0.2877	0.1385
intra beet P_onset to t_peak	-0.1905	0.4744	0.1294
intra beet P_peak to t_finish	-0.1888	1.2588	-0.0496
intra beet P_peak to t_onset	-0.0940	1.0826	-0.0330
intra beet P_peak to t_peak	-0.1430	1.1747	-0.0436
intra beet P_peak to t_onset	-0.2225	1.3023	0.0121
intra beet P_peak to t_peak	-0.1394	1.0977	0.1187
intra beet P_peak to t_peak	0.0498	-0.0522	0.1413
intra beet P_peak to t_finish	-0.0435	0.1232	0.1054

intra beet P_peak to t_peak	0.0453	-0.0240	0.1445
intra beet P_peak to t_finish	-0.1802	0.4588	0.1741
intra beet P_peak to t_onset	-0.0489	0.2188	0.1402
intra beet P_peak to t_peak	-0.1563	0.4056	0.1310
intra beet q_onset to t_finish	-0.3099	1.4385	-0.2127
intra beet q_onset to t_onset	-0.2134	1.2589	-0.1946
intra beet q_onset to t_peak	-0.2632	1.3524	-0.2057
intra beet q_onset to t_onset	-0.3374	1.4845	-0.1582
intra beet q_onset to t_peak	-0.1701	1.2064	-0.0434
intra beet q_onset to t_peak	-0.0349	0.0640	0.0064
intra beet q_onset to t_finish	-0.1321	0.2475	-0.0336
intra beet q_onset to t_peak	-0.0997	0.1838	-0.0247
intra beet q_onset to t_finish	-0.2787	0.5990	0.0290
intra beet q_onset to t_onset	-0.1480	0.3603	-0.0055
intra beet q_onset to t_peak	-0.2558	0.5477	-0.0149
intra beet q_peak to t_finish	-0.1275	1.1356	-0.0970
intra beet q_peak to t_onset	-0.1121	1.0584	-0.1072
intra beet q_peak to t_peak	-0.1226	1.1042	-0.1058
intra beet q_peak to t_onset	-0.1571	1.1205	-0.0008
intra beet q_peak to t_peak	-0.1757	1.1188	0.0260
intra beet q_peak to t_peak	-0.0281	0.0514	0.0062
intra beet q_peak to t_finish	-0.0530	0.1170	0.0123
intra beet q_peak to t_peak	-0.0406	0.0905	0.0059
intra beet q_peak to t_finish	-0.1562	0.3990	0.0982
intra beet q_peak to t_onset	-0.0408	0.1963	0.0485
intra beet q_peak to t_peak	-0.1057	0.3116	0.0668
intra beet r_peak to t_finish	-0.2428	2.3158	-0.1927
intra beet r_peak to t_onset	-0.1459	2.1364	-0.1750
intra beet r_peak to t_peak	-0.1949	2.2285	-0.1854
intra beet r_peak to t_onset	-0.2732	2.3556	-0.1295
intra beet r_peak to t_peak	-0.0763	2.0054	0.0216
intra beet r_peak to t_finish	-0.0932	1.1754	-0.0359
intra beet r_peak to t_peak	-0.0628	1.1122	-0.0253

intra beet r_peak to t_finish	-0.2315	1.5136	0.0317
intra beet r_peak to t_onset	-0.0999	1.2730	-0.0018
intra beet r_peak to t_peak	-0.2071	1.4595	-0.0109
intra beet s_finish to t_finish	-0.1652	2.1638	-0.1650
intra beet s_finish to t_onset	-0.0684	1.9846	-0.1473
intra beet s_finish to t_peak	-0.1179	2.0775	-0.1581
intra beet s_finish to t_onset	-0.1911	2.1970	-0.0997
intra beet s_finish to t_peak	-0.0785	1.9785	0.0019
intra beet s_finish to t_peak	0.0818	0.8419	0.0297
intra beet s_finish to t_finish	-0.0113	1.0170	-0.0062
intra beet s_finish to t_peak	0.0106	0.9771	-0.0101
intra beet s_finish to t_finish	-0.1567	1.3662	0.0577
intra beet s_finish to t_onset	-0.0253	1.1260	0.0239
intra beet s_finish to t_peak	-0.1322	1.3121	0.0150
intra beet s_peak to t_finish	-0.2319	2.2779	-0.1909
intra beet s_peak to t_onset	-0.1135	2.0612	-0.1567
intra beet s_peak to t_peak	-0.1772	2.1786	-0.1783
intra beet s_peak to t_onset	-0.2408	2.2864	-0.1157
intra beet s_peak to t_peak	-0.1520	2.1154	-0.0384
intra beet s_peak to t_peak	0.0594	0.8907	0.0250
intra beet s_peak to t_finish	-0.0162	1.0289	0.0089
intra beet s_peak to t_peak	0.0100	0.9827	0.0072
intra beet s_peak to t_finish	-0.2062	1.4559	0.0388
intra beet s_peak to t_onset	-0.0598	1.1987	0.0075
intra beet s_peak to t_peak	-0.1728	1.3907	-0.0014
intra beet t_finish to t_finish	0.0131	1.7635	-0.2096
intra beet t_finish to t_onset	0.1078	1.5875	-0.1931
intra beet t_finish to t_peak	0.0601	1.6776	-0.2031
intra beet t_finish to t_onset	-0.0277	1.8194	-0.1526
intra beet t_finish to t_peak	0.0504	1.6556	-0.0687
intra beet t_finish to t_peak	0.2456	0.4641	-0.0235
intra beet t_finish to t_finish	0.1524	0.6395	-0.0594
intra beet t_finish to t_peak	0.2254	0.5095	-0.0240

intra beet t_finish to t_finish	-0.0036	1.0054	-0.0018
intra beet t_finish to t_onset	0.1282	0.7648	-0.0354
intra beet t_finish to t_peak	0.0204	0.9523	-0.0448
intra beet t_onset to t_finish	-0.1464	2.0480	-0.1923
intra beet t_onset to t_onset	-0.0498	1.8692	-0.1748
intra beet t_onset to t_peak	-0.0994	1.9622	-0.1857
intra beet t_onset to t_onset	-0.1790	2.0916	-0.1310
intra beet t_onset to t_peak	-0.0651	1.8602	-0.0201
intra beet t_onset to t_peak	0.0928	0.7384	-0.0026
intra beet t_onset to t_finish	0.0013	0.9111	-0.0375
intra beet t_onset to t_peak	0.0557	0.8036	-0.0063
intra beet t_onset to t_finish	-0.1262	1.2309	0.0376
intra beet t_onset to t_onset	0.0044	0.9921	0.0033
intra beet t_onset to t_peak	-0.1029	1.1789	-0.0058
intra beet t_peak to t_finish	-0.0319	1.8511	-0.1804
intra beet t_peak to t_onset	0.0667	1.6687	-0.1613
intra beet t_peak to t_peak	0.0165	1.7627	-0.1726
intra beet t_peak to t_onset	-0.0665	1.8971	-0.1195
intra beet t_peak to t_peak	0.0129	1.7246	-0.0311
intra beet t_peak to t_peak	0.2061	0.5430	0.0092
intra beet t_peak to t_finish	0.1129	0.7183	-0.0268
intra beet t_peak to t_peak	0.1717	0.6076	0.0033
intra beet t_peak to t_finish	-0.0339	1.0693	0.0366
intra beet t_peak to t_onset	0.0975	0.8293	0.0028
intra beet t_peak to t_peak	-0.0098	1.0160	-0.0064

14.5 Implementations of Selected Algorithms

The full implementation of this work is made available on the SourceForge website, the project page is <http://sourceforge.net/p/creemers2013phd>. However, as time has a habit of destroying online resources, this appendix contains implementations of selected algorithms developed during the course of this research.

A summary of the files contained in the project.

Language	files	comments	Lines of code
C#	582	42,077	148,580
MATLAB	889	19,334	38,536
C++	25	655	5,288
C	14	811	2,279
C/C++ Header	33	1,036	1,652
Lua	27	319	1,567
DOS Batch	5	0	83
make	1	10	25
SUM:	1,576	64,242	198,010

Compilation requires MatLab 2009+, Visual Studio 2010+

14.5.1. Linear Criterion for ECG subtraction procedure.

This section holds only a portion of our implementation of the subtraction procedure, due to the size of the code a full listing was not possible. This portion was given because it was an alteration to the method advocated by Levkov et al., (2005) which improved our results.

The rest of the code is available via <http://sourceforge.net/p/creemers2013phd>.

```
/// <summary>
/// Linear criterion as described on page 3 of Levkov et al 2005.
/// Tweaked for better performance.
/// </summary>
/// <param name="data">Data to be processed</param>
/// <param name="sampleRate">Sample rate of signal</param>
/// <param name="noiseFreq">frequency of noise in Hz</param>
/// <param name="threshHold">160µV, 150µV and 100µV are known good thresholds.</param>
/// <returns></returns>
private static double[] linearTest(double[] data, int sampleRate, double noiseFreq, double
threshHold)
{
    threshHold = threshHold * 1000;
    int consecutiveFirstDifferences = 6;
    double[] r = new double[data.Length];

    int n = (int)(sampleRate / noiseFreq);
    if (n < 1)
    {
```

```

    n = 1; //stops a bad calculation and crash
}

for (int pos = 0; pos < data.Length - consecutiveFirstDifferences - n; pos++)
{
    double min = double.MaxValue, max = double.MinValue;

    for (int i = 0; i < consecutiveFirstDifferences; i++)
    {
        double difference = data[pos + i + n] - data[pos + i];
        if (difference > max)
        {
            max = difference;
        }
        if (difference < min)
        {
            min = difference;
        }
    }

    r[pos] = ((max - min) < threshHold) ? 1 : 0;
}

//flatten out the diference graph a bit
int halfFlattenSize = (int)(n * 1.5);
int entropy = 0;
double smoothAgainst = 0;
for (int i = 0; i < (r.Length - halfFlattenSize); i++)
{
    if (r[i] == smoothAgainst)
    {
        entropy = halfFlattenSize;
    }
    else if (entropy > 0)
    {
        entropy--;
        r[i] = smoothAgainst;
    }
    else
    {
        for (int f = 0; f < halfFlattenSize; f++)
        {
            if (r[i + f] == smoothAgainst)
            {
                r[i] = smoothAgainst;
                break;
            }
        }
    }
}

//fill in the last 6 spots
for (int pos = (data.Length - consecutiveFirstDifferences - n); pos < data.Length; pos++)
{
    r[pos] = 0;
}

return r;
}

```

14.6 Assorted Notices and Communications Used

An advert, shown in Figure 397, was used to gain the support of student nurses as staff in the experiment. This advert was distributed by the school of nursing to their best final year students.

STUDENT NURSES REQUIRED



The School of Computer and Information Science requires 3 student nurses to aid in conducting a series of Research experiments.

The experiments involve placement of electrodes on volunteers and monitoring of physiological signals. A safe, sterile and professional environment is being set up for this research. In accordance with provisions set forward by the universities ethics committee student nurses will be responsible for accurate, safe and ethical placement of all electrodes.

Experiments are conducted on the ECU Mount Lawley campus. Student nurses will be responsible for placement of electrodes on approximately 35 volunteers.

Each experiment is expected to last approximately 15-20 minutes. With only about 3 minutes work per experiment for the student nurse.

Student nurses will be rewarded for their help with

- \$100 Bookshop gift voucher
- Letter of appreciation (great for C.V.'s)

Interested students please contact:

Warren Creemers
9370 6998
w.creemers@ecu.edu.au

Figure 397: Advert for nurses

A notice was placed along corridors to stop students conducting wireless surveys proceeding too close to the laboratory (see Figure 398).

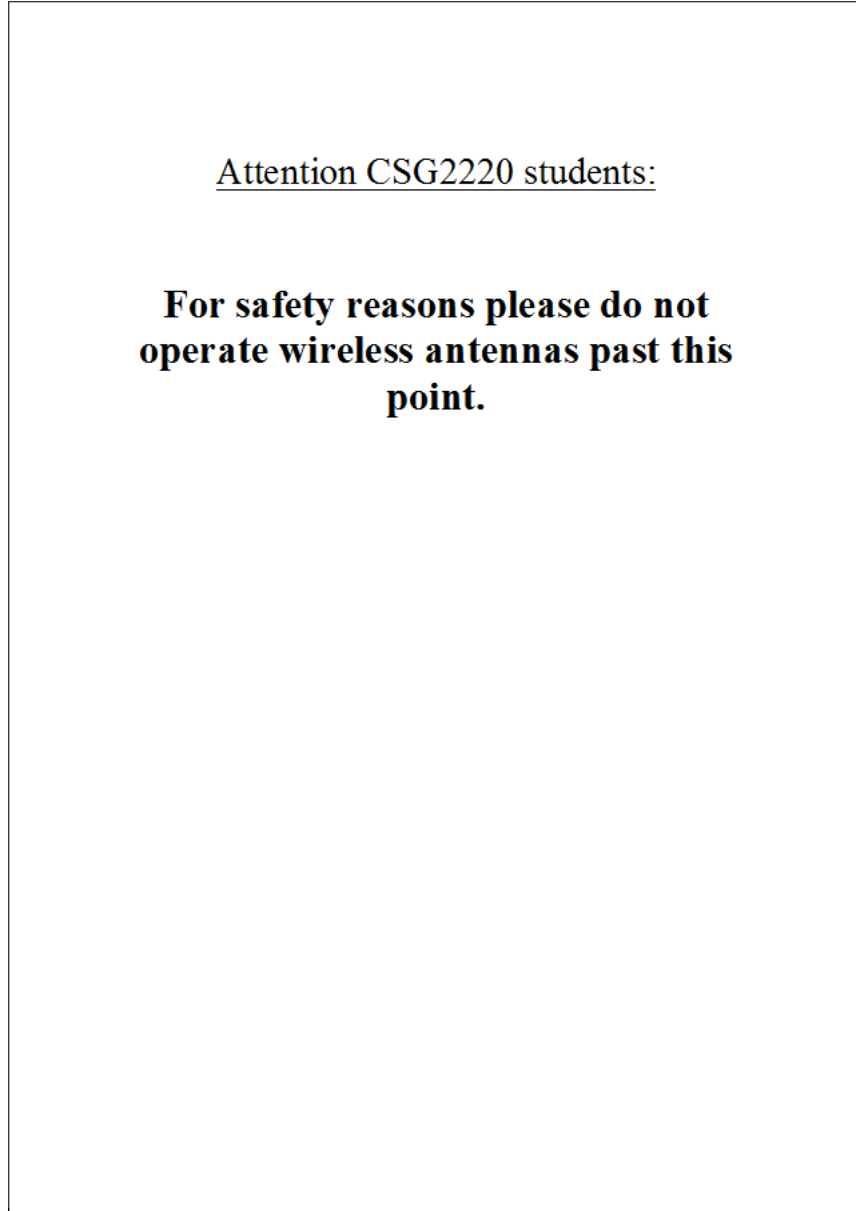

Figure 398: Notice to other students.

An advertisement (see Figure 399 and Figure 400) was used to seek volunteers for the study. (The device shown was a popular MP3 player in Perth Western Australia at the time of the experiment; MP3 players at the time being a luxury item).

Win a Creative Nomad "MuVo" MP3 player!

Volunteers Required.

Approximately 100 student volunteers are required to participate in a biofeedback experiment being conducted in the School of Computer and Information Science. The experiments are being conducted during August, 2004 on the Mount Lawley campus.

From these participants one person shall win a new Creative MP3 player (128-MB).

To participate we require about 15 minutes of your time as you are connected to some biofeedback equipment and view a short slide show.

If you are able to assist in this work please contact Warren Creemers on 9370 6998 or send an email to biofeedback@scis.ecu.edu.au



The image shows a Creative Nomad MuVo MP3 player, a small, dark-colored device with a white earphone attached. The device has 'CREATIVE' and 'NOMAD' printed on it, and 'MUVO 128MB' is visible on the side. A black cable is connected to the top.

Figure 399: Advert for volunteers (for noticeboards)

A handout version of the same advert.

Win a Creative Nomad "MuVo" MP3 player!

Volunteers Required.

Approximately 100 student volunteers are required to participate in a biofeedback experiment being conducted in the School of Computer and Information Science. The experiments are being conducted during August, 2004 on the Mount Lawley campus.

From these participants one person shall win a new Creative MP3 player (128-MB).

To participate we require about 15 minutes of your time as you are connected to some biofeedback equipment and view a short slide show.

If you are able to assist in this work please contact Warren Creemers on 9370 6998 or send an email to biofeedback@scis.ecu.edu.au for more information or to make an appointment.

Warning:
Participation in this experiment may involve exposure to strong images.



The image shows a Creative Nomad MuVo MP3 player, a small, dark-colored device with a white earphone attached. The device has 'CREATIVE' and 'NOMAD' printed on it, and 'MUVO 128MB' is visible on the side. A black cable is connected to the top.

Figure 400: Advert for volunteers (handout)

An instructional notice was present in the room, see Figure 401.

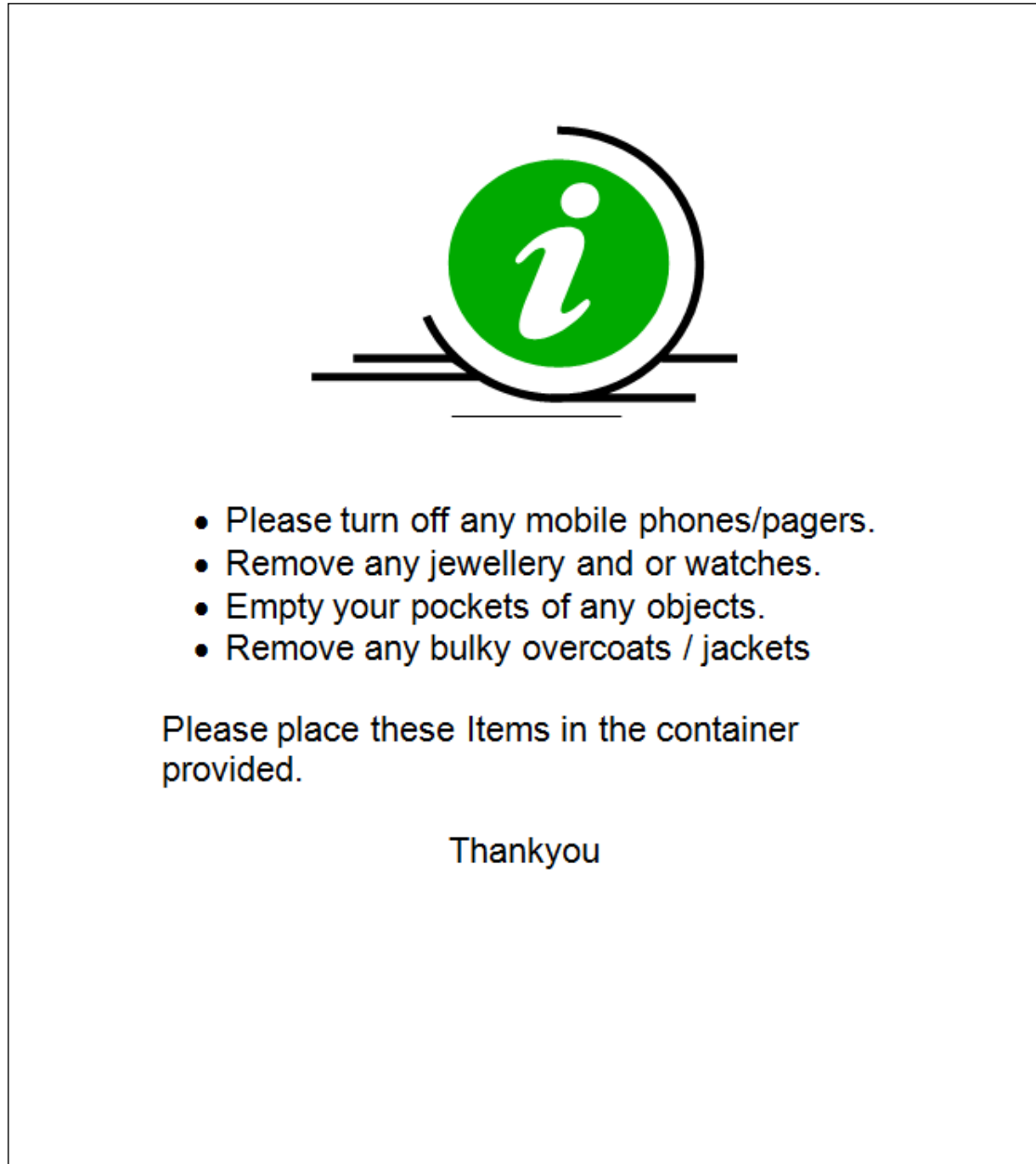

Figure 401: Notice displayed facing entrance to room.

The disclosure forms are shown in Figure 402 and Figure 403. A Informed consent form was also signed by all participants Figure 404. Originally these forms were printed on heavy stock with university letter head.

DISCLOSURE

(Please Retain this Page)

Project: Neural Network Refinement of the Emotion Classification Problem

This experiment is designed to monitor and record biological signals generated by participants as they view a slide show. Participants will answer a questionnaire for each slide designed to record how the slide made them feel. The signals recorded will be analysed in an attempt to discover if there is a link between these signals and the subjects' emotional state.

To assist in the analysis of data collected it will be necessary to record the participants' height, weight age, gender and information about their mood during the day prior to the experiment.

Please be advised that the slide will contain some strong scenes. You, the participant, may be exposed to images containing death, violence, horror, erotica, mutilation and/or nudity. If you feel uncomfortable with this please inform the researcher that you no longer wish to participate. You will be excused no questions asked.

If any of the images you view during this experiment leave you feeling upset or uncomfortable you are entitled to a free concealing service provided by university counsellors. Please ask the person conducting the experiment to arrange this service should you require it.

No names or contact details will be recorded or associated with the recordings. The data collected will remain anonymous to protect the privacy of the participants. It is likely that the (anonymous) data recorded will be published and made available to other researchers for purposes of scientific research.

This experiment should take approximately 15 minutes of your time. If during the course of the experiment you find any content displayed to be offensive or you feel that you would not like to continue please press the stop button provided and the experiment will be halted and the projector turned off. Please remember you participation is voluntary and you have the right to cancel your participation at any time and for any reason without the need for any explanation.

Please note that your health and safety during this experiment is being catered for. For this reason all electrodes and sensors used are non-invasive. Where appropriate all electrodes and sensors are attached by a person qualified to do so. All possible care has been taken to ensure that your skin will not come in contact with any substances capable of producing an allergic reaction. Should any of the electrodes attached feel uncomfortable, itchy or irritating please ask the person who attached your electrodes for assistance.



MOUNT LAWLEY CAMPUS
2 Bradford Street,
Mount Lawley
Western Australia 6050
Telephone 934 528
Facsimile 934 529
400 54 361 400 362

Figure 402: Disclosure form (1 of 2)

Disclosure form (Page 2)

We must ask that if you have consumed a significant amount of coffee, alcohol or have smoked a cigarette in the last hour that you not participate in this experiment. If you take mood altering medication or recreational drugs on a regular basis or have done so recently we also ask that you not participate in this experiment. These exclusions are made purely for scientific reasons if you fall into one of these categories you will be excused no questions asked.

If, at this point, you have any questions please ask the person conducting the experiment to help you. If you wish to contact someone concerning any issues with this experiment or related research please feel free to contact:

Any questions concerning the project entitled "Neural Network Refinement of the Emotion Classification Problem" can be directed to:

Warren Creemers (Principal Investigator)
(School of Computer and Information Science)
ph: 9370 6313
e-mail: w.creemers@ecu.edu.au

OR

Assoc/Prof Wojciech Kuczborski (Principal Supervisor)
ph: 9370 6013
e-mail: w.kuczborski@ecu.edu.au

If you have any concerns about the project or would like to talk to an independent person, you may contact:

Mike Gavin (Manager, Occupational Health & Safety)
ph: 9300 2302
e-mail: m.gavin@ecu.edu.au



MOUNT LAWLEY CAMPUS
2 Bradford Street,
Mount Lawley
Western Australia 6050
Telephone 939 328
Facsimile 181 91 9370 2510
408 54 301 408 301

Figure 403: Disclosure form (2 of 2)

Consent form

Consent (For university records)

Project: Neural Network Refinement of the Emotion Classification Problem

I hereby state that I am, to my knowledge of sound mental state and am over the age of 18. I furthermore state that I am currently enrolled as a student in Edith Cowan University.

I understand that by participating in the experiment I may be exposed to images and media of a strong and unpleasant nature. I (the participant) have read the information above (OR "have been informed about all aspects of the above research project") and any questions I have asked have been answered to my satisfaction.

I acknowledge that my participation in this experiment is voluntary and I am here of my own free will. I agree to participate in this activity, realising I may withdraw at any time.

I agree that the research data gathered for this study may be published provided I am not identifiable.

Participant

Name: _____ Signature: _____ Date: _____

Investigator

Name: _____ Signature: _____ Date: _____



MOUNT LAWLEY CAMPUS
2 Bradford Street,
Mount Lawley
Western Australia 6050
Telephone 939 328
Facsimile 181 91 9370 2510
408 54 301 408 301

Figure 404: Informed consent form

14.7 Risk Management Report

What follows is the risk management report as presented to and approved by the Human Research Ethics Committee and the Occupational Health and Safety department. The report was written prior to the room being acquired and some fine tuning of procedures.

Project:

Neural Network Refinement of the Emotion Classification Problem

Researcher:

Warren Creemers

Principle Supervisor:

A/Prof. Wojciech Kuczborski

Submitted 12th March 2003 (in surplus of requirements) as part of the Application to Undertake Research Involving Human Subjects to the Human Research Ethics Committee of Edith Cowan University.

Contents

- 1.0 Introduction
- 2.0 Operating Procedure
- 3.0 Identification of key risks
 - 3.1 Risk Prioritization
- 4.0 Risk Minimization Strategies
 - 4.1 Minimization of Emotional Distress Risk
 - 4.2 Minimization of Electrocutation Risk
- 5.0 Risk Response Strategies
 - 5.1 Response to Emotional Distress Risk
 - 5.2 Response to Electrocutation Risk
- 6.0 Conclusion
- 7.0 - Risk Calculations

1.0 Introduction

Two main risks have been identified with the data collection phase of the project. These risks are concerned with the health and safety of the participants in the experiments to be conducted. Due to the nature of their impact these risks are given serious attention and an appropriate management strategy is being adopted to ensure that no-one is in any way harmed through their participation in this experiment.

2.0 Operating Procedure

The experimental procedure here is preliminary and will undergo refinement before collecting the final data. This procedure is a guide to show the scientific method in use and to allow for ethical considerations to be examined.

To collect training data volunteers will be fitted with a Thought Technology ProComm Sensing System and will then view segments of the International Affective Picture System (IAPS) slide database. Figure 1.0 illustrates the set-up of the experiment.

A room will be prepared for experimental work. There will be no pictures on the walls of the room and the room will be kept as sparse as possible. A divider will be placed in the room and a computer used to control the experiment will be placed behind it. At the rear of the room a clock might be positioned for the convenience of the experiment operator.

When a subject enters the room the operator will advise the subject that the slides about to be viewed may include offensive or unpleasant material. The subject will be required to sign a Disclosure and Informed Consent form.

The subject will be fitted with the ProComm Sensing System by the operator and be seated in a comfortable chair. The sensing system will be connected to a recording computer via a data cable. The room will then be darkened and the operator will stop any communications with the subject and move out of sight behind the divider. The subject will be left for one minute to let the subject's heart rate come to rest. After the subject is at rest the projector will start displaying a sample of the IAPS slide database. Three random slides will be displayed to avoid possible biases caused by the presence of anticipation and to engage the subject. After this warming up period, six slides for each emotion to be detected will be displayed in random order. Three of the slides will invoke the emotion and three of the slides will cause the emotion to not be present. To ensure accuracy each slide will need to be validated to show the desired affect in the subject was achieved. This can be done via self assessment with the user providing feedback on how each slide made them feel.

After the experiment is complete the operator will check to see if the user has not been adversely affected by the slides content (left in a state of distress). If a subject is adversely affected (unlikely) the operator should direct the user to an on campus councilor and mark the result extracted as biased and probably unusable.

After the experiment is completed the operator will record the user's height, weight, age and gender.

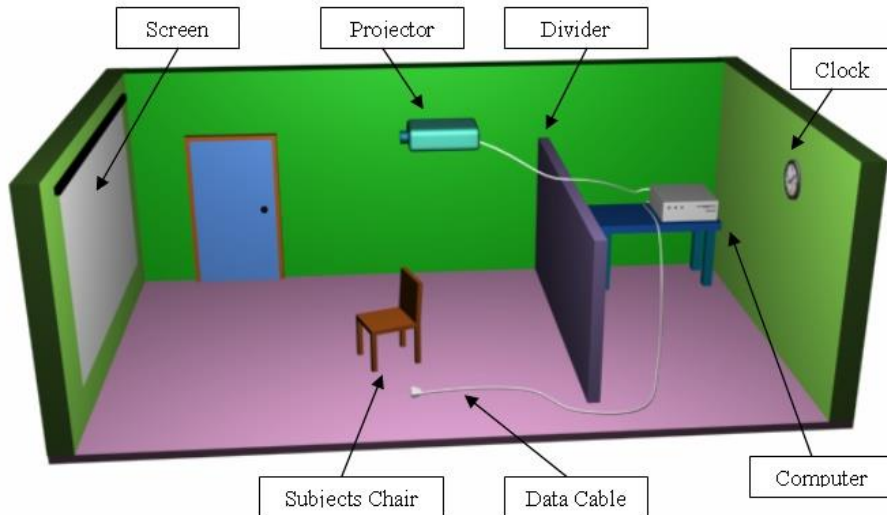

Figure 1.0: Experiment setup

Similar experiments may be conducted using interactive software (word processor or video game) to examine emotional state during computer use. These experiments will not contain any un-pleasant or explicit content.

3.0 Identification of key risks

Two key risks are identified in this document:

- 1: Emotional distress
- 2: Electrocutation

The risk of emotional distress refers to a subject being exposed to an image in the IAPS that the subject feels is overly unpleasant or offensive. This risk occurs because part of the content of the IAPS database is very strong. At worst a subject may be exposed to scenes containing horror, nudity, death and erotica.

The risk of electrocution refers to the presence of electrodes on the human skin. This risk is similar to the risk involved with using an underwater low-voltage pool lamp. The risk is serious not because electrocution is more likely, but because of the increased impact of any electrical shock.

When electrodes are placed on human skin any power surge in the machinery connected to the electrode could (if unsafe or damaged equipment is used) pass straight to the person and provide an extremely dangerous situation. The situation is potentially dangerous because of:

- The proximity of the electrode to vital organs (such as the heart);
- The fact that the electrodes are attached to the person.

3.1 Risk Prioritization

To prioritize these risks a priority scale is adopted. The probability of the risk is estimated (0% -100%) and the impact of the risk on a scale of 1 to 100 is determined. The two statistics are multiplied and used as a measure of importance (0-1000). See Appendix 1 for calculations used to populate the following table

Risk	Probability	Impact	Importance
Emotional Distress	0.000055%	10	0.00055
Electrocution	0.000000093%	99	0.0000092

By these calculations emotional distress is deemed to be the most important risk in the project.

4.0 Risk Minimization Strategies

The risk management strategies presented here will reduce the possibility of any risk occurring to a level compliant to Australian & university standards.

4.1 Minimization of Emotional Distress Risk

The risk of emotional distress applies mainly to people who already have a strong aversion to a particular type of content. Generally speaking most people with such aversions are aware of them and would not choose to view content they knew could upset them. This is the basis of the content advisory system used in Australia to deal with this same risk as it applies to public television.

The first stage of managing this risk involves alerting people to the content during the recruitment phase. If a subject is aware of the risk before agreeing to take part in the experiment then a subject can make an informed choice on whether to volunteer or not. It also avoids the situation in which someone volunteers for the experiment and only finds out about the content when signing a consent form. Under these circumstances it may be possible for someone to feel pressured into participation so as not to waste the operator's time or have to admit to being sensitive to content.

The second stage of managing this risk involves the operator of the experiment alerting the volunteer to the type of content that can be expected and providing as much as possible a "pressure free" environment for the volunteer to decline participation. After this the Informed Consent and Disclosure forms will be offered to the volunteer. The experiment will not commence until these forms are signed.

At this stage all volunteers with known aversions to content have had an opportunity to withdraw. The third stage of this management plan deals with volunteers who, for some reason, did not withdraw from the experiment when they felt content may affect them. This stage also deals with those volunteers who did not realize they would be sensitive to a particular content. To deal with this situation the volunteer will be informed of actions he/she can take if any content upsets them. These actions include the volunteer being able to:

Have the experiment stopped at any time (with the projector immediately turned off);

Leave at any time, no explanation required

The subject will be informed of these rights at the beginning of the experiment before any work is commenced. To aid in allowing the subject to leave at any time there will be only one subject allowed in the room at any time. This is done to avoid "peer pressure" which may cause a subject to remain against their will.

There is lastly a risk that someone with an aversion to content who did not volunteer for the project may come barging through the door to the room being used for the

experiment. To manage this risk a do not disturb notice may be posted on the door. At no point will the door be locked, the “free to leave any time” environment cannot be compromised to handle such a small and unlikely risk.

4.2 Minimization of Electrocutation Risk

The risk pertains to:

Mains operated equipment used with sensors designed for connection to the human body.

Non-Mains operated equipment that utilizes a non-optically-isolated data connection to a mains powered computer or recording device.

The second type of equipment is fundamentally unsafe during a power surge and will not be used in this work. Thus this risk applies to management of mains operated equipment used with sensors designed for connection to the human body.

Firstly all such equipment would only be purchased where all government guidelines for equipment suitable for use on humans are met. This equipment would be presented to the university occupational health and safety officer along with an operations plan for the experiments to be conducted. After Ethics clearance is received no experiments will be conducted until the experiment passes and occupational health and safety inspection.

Defective equipment may fail to isolate the subject from a mains power surge. For this reason any damage to equipment will be recorded and where necessary damaged units will be sent to a biomedical equipment technician for a safety report. Units found unsafe will undergo repairs (by a biomedical equipment technician) or disposal. The serviced equipment will be brought to the attention of the OHS officer for re-approval before being used again.

Where possible, Non-Mains operated equipment that utilizes an optically-isolated data connection will be used in preference to any mains operated equipment. This is because such a piece of equipment if in working order poses no real risk to participants.

5.0 Risk Response Strategies

Risk mitigation strategies are intended to provide a procedure to follow in the event of an identified risk occurring. The focus on the procedures presented here is the practicality of the procedures to be followed.

5.1 Response to Emotional Distress Risk

A university councilor will be informed of the type of research being conducted to ensure that in the case of someone being distressed by any image, appropriate counseling is available.

5.2 Response to Electrocutation Risk

There is no practical method to mitigate the electrocution risk. An ambulance will be called in the event of any electrocution. The approach to this risk is currently focused on preventative measures.

The occupational health and safety officer will be asked to advise on the inclusion of the following Items:

- A first aid station and/or box;
- First aid training for staff running the experiment;
- A resuscitation /electrocution chart.

6.0 Conclusion

Many of the risks visited here are unlikely to occur, but are presented here in a strait forward and open manner. The risks though highly un-likely are treated very seriously because of the nature of their impact.

It must be stressed that the proposed experiments conducted in a professional manner are safe. The risks shown relate mainly to results that can occur if the experiment was conducted in an unethical manner or if unsafe equipment is purchased.

A second report on the final state of apparatus and the results of OHS inspections will be made available on request to demonstrate the correct implementation of all procedures outlined in this document.

7.0 Risk Calculations

Electrocution

Probability Calculation

Conditions for risk to occur:

Massive Power Surge (1/16000hr)

AND

Equipment becoming unsafe (0.0001%)

AND

Surge not stopped by university power regulators (0.5%)

$$= 0.0000625\%/hr * 0.0001 * 0.5$$

$$= 0.00000003\% \text{ chance of electrocution per hour of usage.}$$

Estimated volunteers = 100

Time per experiment = 0.3hr

$$= 30hr \text{ usage at } 0.00000125\%/hr$$

$$= 0.000000093\% \text{ chance of electrocution occurring during duration of project.}$$

The probability of a participant being harmed by the equipment is approximately 1 in 30 million.

Impact Calculation

Probable impact:
80% fatality

Assigned impact value – 99

Emotional distress

Probability Calculation

Conditions for risk to occur:

Person is sensitive to material (1%)

AND

(Person fails to withdraw from experiment (1%))

OR

(Person is unaware of sensitivity (0.1%))

AND

Material is shown (50%)

AND

Material has lasting effect (1%)

$$= .01 * (.01 + .001) * .5 * .01$$

$$= 0.0000000055 \text{ or } 0.00000055\% \text{ chance per person}$$

Estimated volunteers = 100

=0.000055% chance of incident during duration of project.

This experiment would be upsetting to one in every 18,000 participants.

Impact Calculation

Probable impact:

99% unpleasant thoughts to possible nightmare

1% serious problem (not caused by experiment, just triggered)

Assigned impact value – 10

14.8 Email sent to all would be volunteers

General Information.

Participation in this experiment is done by appointment. Attached to this email is a HTML document indicating the currently available appointment times. The experiment takes about 15 minutes and involves watching a slide show containing images from an international research project. Please note that some of these images contain strong scenes that may offend some viewers.

During the experiment you will have a panel of buttons which you can use to express your opinion on the images shown. Your feedback is anonymous and your identity is not recorded or associated with any of the data collected.

At the end of the experiment you can put your details on a raffle ticket. After 100 experiments are completed a Creative Nomad (128mb) Mp3 player will be raffled and the winner contacted to collect their prize.

The Equipment

The biofeedback equipment being used is safe, the lab has Occupational Health and Safety clearance and the experiment is approved by the Edith Cowan University Ethics Committee.

Sensors Used

Six non-allergenic adhesive electrodes will be attached to your arms and face.
4 elasticised sensors will be placed over your fingers.
1 respiration sensor worn over any non bulky clothing will be wrapped around your chest.

There are **no** needles or other invasive / hazardous instruments being used in this work. All sensors will be attached by qualified nursing students from the School of Nursing.

Before Arriving.

We ask that you not drink coffee (or a caffeinated drink), consume alcohol, or smoke a cigarette for 3 hours prior to the experiment. It would be preferable if you wore a loose fitting t-shirt so that electrodes can easily be connected to your arms.

To make an appointment.

Simply nominate which of the timeslots from the attached list you would like. The time slots given out on a first come first served basis.

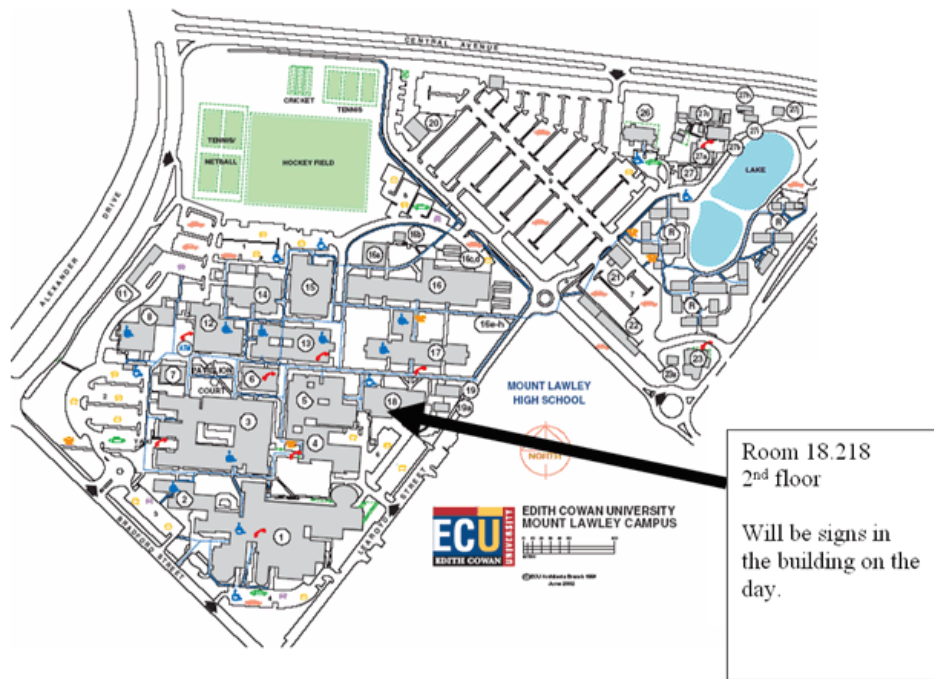

14.9 Median Filtering Algorithm

Our algorithm, termed oobTree, was verified to produce the same results as the matlab 2009b filter (medfilt1) and has been made publicly available (W Creemers, 2010) to help other researchers in cardiology.

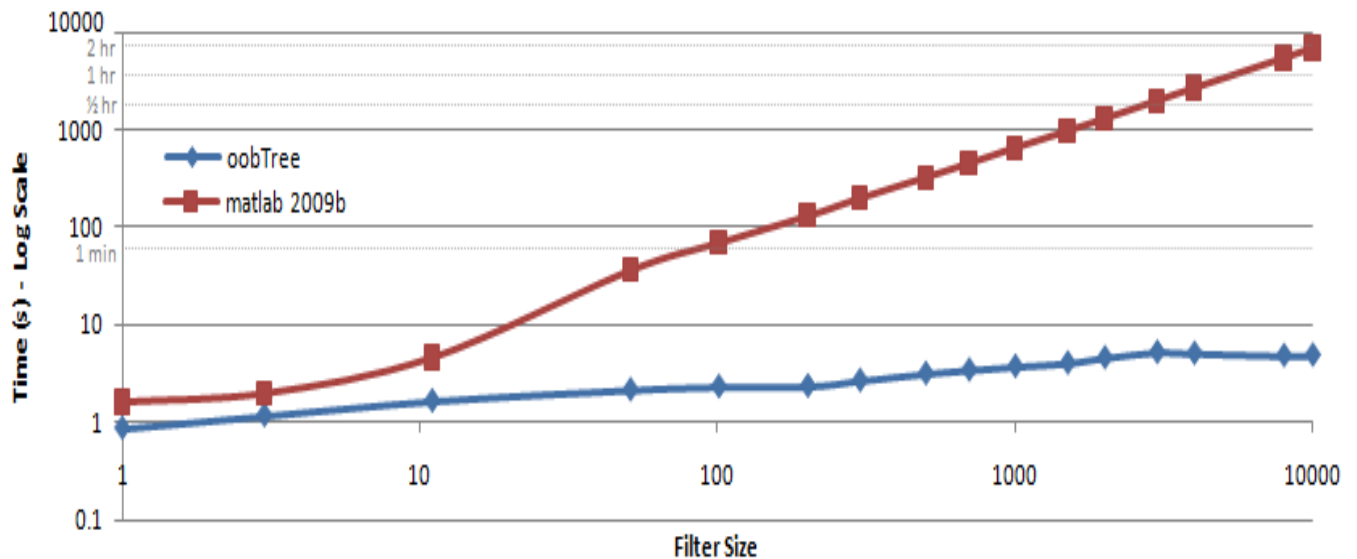

Figure 405: Median filter performance comparison for a 2.66GHz quad core Intel Q9450 (our solution is oobTree)

As can be seen in Figure 405 (note: using log scale axis) median filter performance is still expensive on hardware circa 2010 and our algorithm is capable of computing datasets that would otherwise take over 2 hours in under 10 seconds.

Previous algorithms such as described by Pratt (W. . Pratt, 1978) offer $O(N \cdot \log W)$ performance, where W is the filter size, and N is the number of samples to be processed. Our algorithm presents an order N solution, that is to say the window size has little impact on performance, but signal morphology does).

The algorithm we developed for median filtering operates by maintaining a binary tree which indexes a circular buffer. The tree (and also the circular buffer) holds all the data being evaluated for the current window position.

Each node in the binary tree stores the total amount of children (designated c) beneath it and is uniquely referenced by its position i in the circular buffer.

When it is necessary to find the median value of the window, it is the root node of the tree if the tree is kept balanced, or if the tree is not self balancing searchable by recursive iteration using c as a guide to increase performance.

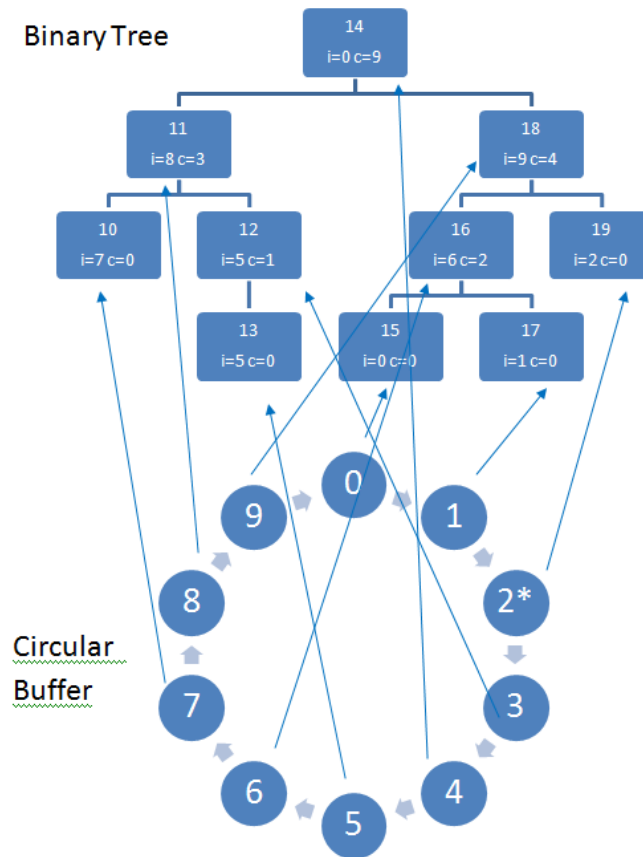

Figure 406: Structure used for efficient median filtering

When the window is shifted forward one sample, the item at the tail of the circular buffer is removed from the tree and all parent c values updated. The next item now included by advancement of the window is added to the tree and linked to the head of the circular buffer.

As the cost of advancing a window is very low (two tree operations) and finding the median value in the tree is generally very cheap, the algorithm tends to exhibit excellent performance.

Some notes on the algorithm and its performance:

1. It is possible to avoid the overhead of memory allocation by reusing nodes in the binary tree as this will help microcontroller implantations;
2. Signal morphology affects performance;
3. The more balanced the tree is the quicker the search for the median will be;
4. Our investigation would suggest that self balancing trees are generally not necessary for real world data sets as the tree tends to stay well balanced;
5. It is possible to implement the tree recursively for $W < 10,000$ on a PC;
6. The algorithm is only advisable for large windows ($W > 20$);
7. The algorithm is not virtual memory aware. If the window size is sufficient to occupy all available physical memory it will typically generate two page faults per window advancement;
8. The algorithm is able to work with streamed data and does not require more data than the window size to operate.

There is a major problem if a signal has no noise and prolonged linear segments (approaching half W). This will cause the tree to form a completely unbalanced structure because the relationship of each successive point is the same. As a result the tree will form a linked list type structure as per Figure 407. In this case performance is $O(\frac{W}{2})$ and the results are similar to other optimised median filtering techniques. In this way it can be said our technique exploits the noisy nature of real world data to achieve a performance boost. The algorithm is not as efficient for some tasks that work with synthetic data.

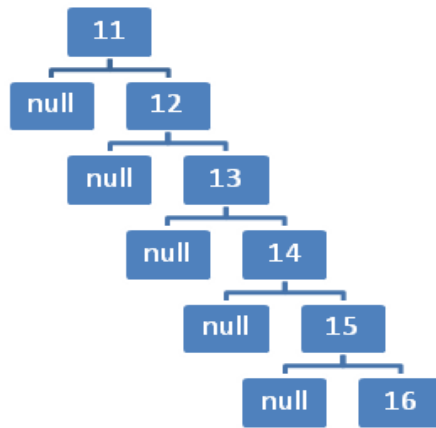

Figure 407: Unbalanced tree

It is possible to allow for the null signal (constant reading) to progress smoothly through the filter without the issues previously discussed, by having the tree assign smaller numbers left, larger numbers right and equal numbers either way by means of a quasi random process.

14.10 Hardware SAM Circuit Diagram and Information

This section of the appendix contains all the information needed to build and operate our SAM panel. This device and related documentation was a collaborative effort with SCIS research support team. The source code for the embedded system and PC controller are available online: <https://sourceforge.net/projects/samhardware/>.

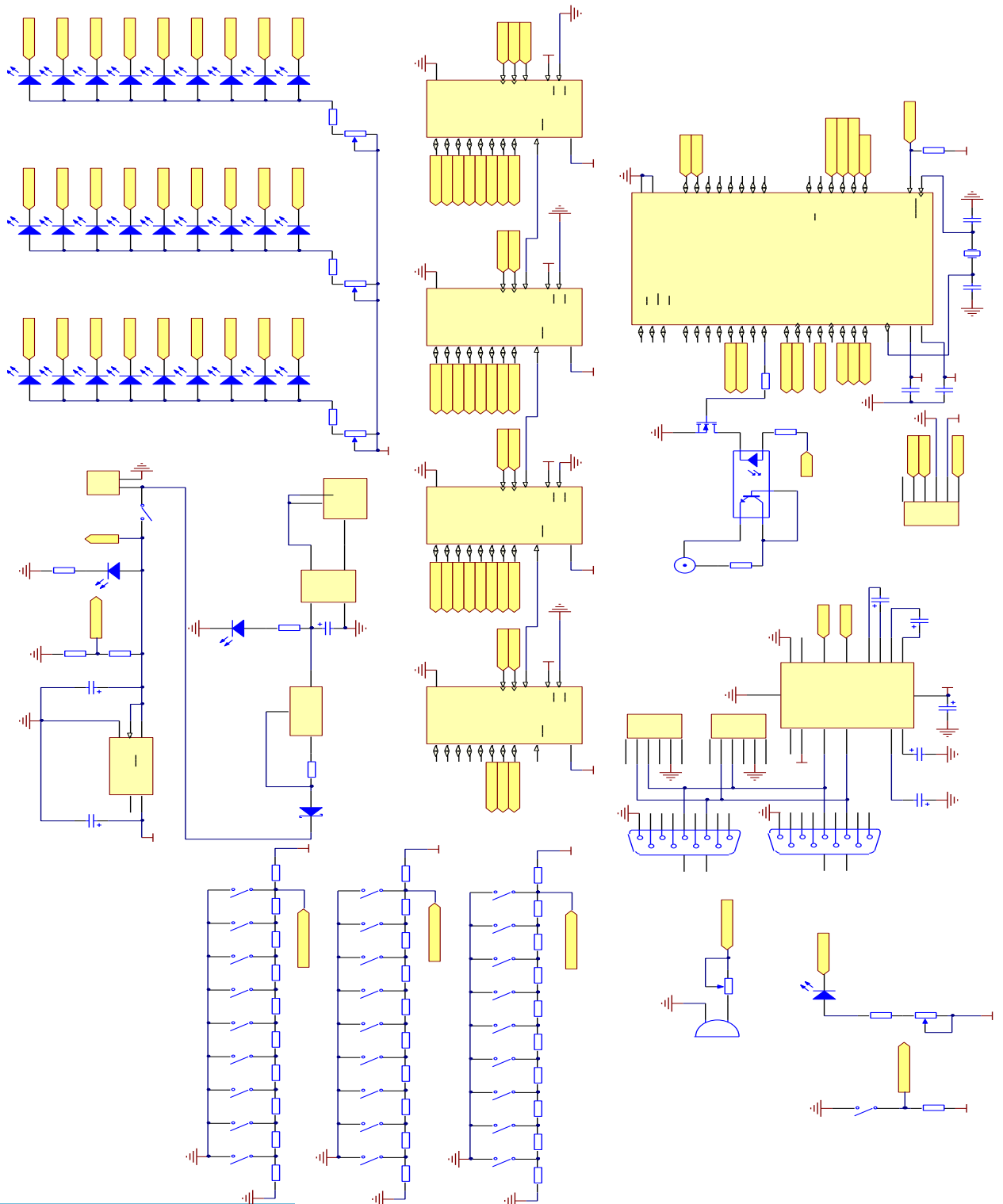

Figure 408: SAM tablet circuit diagram

14.10.1. **Microcontroller**

The microcontroller is a Microchip PIC 18LF452. The LF series is guaranteed to work within specification with a 3.3V supply. The oscillator is a 4Mhz ceramic. An additional 17 input/output ports are available for future expansion.

14.10.2. **Power Supply**

A slider switch on the rear of the unit powers the device on, and illuminates a small red LED. Power is provided by four 1.2V NiMh batteries. At full charge and without LEDs switched on, these may read approximately 5V. A regulator brings this voltage down to 3.3V. The regulator used is the LP29801M5-X3.3, chosen for its low quiescent power and low dropout voltage.

A battery charge circuit is also provided. This requires between 9 and 12V AC or DC, at 200mA. As this represents the ten percent charge rate of the cells, the charger may be left on indefinitely. Furthermore, the unit may be operated whilst charging. A green LED on the rear of the unit indicates charging is taking place.

Total quiescent current consumption is 6.56mA. With one LED on in each row, adjusted to high intensity, this is approximately 10mA. As the batteries are rated at 2000mAH, the switchbox may therefore be operated for approximately 200 hours between charging.

Battery level may be requested by the Host with the BATL command. The microcontroller reads the level on a voltage-divider (ref: schematic, Appendix 5, R103,R104), and returns a value representing the percentage of charge, ranging from 0% to 100%. The divider reduces the maximum battery input voltage from 5V to 3.08V. This voltage is fed to the AN0 input (pin 2 of the microcontroller) where it is converted to an 8 bit value. This is then converted to a percentage of 3.3V, and returned to the Host. This value is only intended as a rough indication of battery charge state, as the relationship between capacity and voltage is non-linear. The microcontroller brownout-detector will activate at 2.2V, resetting the switchbox.

14.10.3. **Audio Tone Output**

An audio output is provided in the form of an electrostatic transducer, attached to port RD2 of the microcontroller. This produces tones ranging from 100hz to 4700Hz. A potentiometer (screwdriver adjustable trim-pot) mounted on the back panel permits adjustment of the volume.

The range is set by defines in Globals.h. The setAudio() function (in Globals.C) is used to control the on/off state and frequency of the tone. When the microcontroller receives an AUON command from the Host, Timer1 is enabled. This is primed with a count value determined by the AUxy command. The 16 bit timer counts up from this value, and overflows, producing an interrupt. The interrupt service routine (ISR()) then toggles the speaker output on port RD2, and reinstates the pre-load value. This process repeats indefinitely, producing an audible output, until the AUOF or RSET command is received.

14.10.4. **Microphone Output**

A high impedance 2Kohm dynamic microphone is mounted on the inside of the enclosure, to pick up switch depression noise. The output signal is provided at the output via a 3.5mm audio socket. Cabling should be coaxial to improve noise performance.

This output may be plugged directly into a sound-card for monitoring or later analysis.

14.10.5. **Synch Output**

When the Host transmits an Sxyz command (eg: 'S200'), the microcontroller outputs the specified number of pulses, of 39mSec duration, to port RD0. This pulse train switches a 4N26 phototransistor opto-coupler, which provides an isolated pulse-train at the 3.5mm output socket on the back of the instrument.

The configuration used provides 7500 AC volts of isolation from input to output. No active voltage is provided at the output. However, with no load attached, the photo-

voltaic effect produces a waveform with a 0 to peak value of approximately 0.3v. The output lead contains a 10k resistor, to better mimic the characteristics of human skin. This output may be used to attach directly to a Galvanic Skin Response input.

14.10.6. SAM LED Outputs

A total of 27 LEDs are mounted on the PCB. When the Host issues the LTx_y command, (eg: LTA3), the microcontroller lights the appropriate LED. When a ‘clear’ command such as CLRZ, CLR1, CLR2 or CLR3 is issued, function clearLEDs() is called, and LEDs are cleared. Each of these commands makes use of the setLED() function.

LEDs are not attached directly to the PIC, but must be accessed via four daisy-chained serial shift registers. Function setLED() loads a static array with the (passed) status of the LED to be switched. Being static, this array maintains its list of LED status between calls. The array is then clocked out of the PIC to the first serial register. When all twenty-seven array values have been loaded, the strobe input is pulsed, transferring bits in each serial register to the LEDs on the parallel outputs.

LED intensity may be varied for each row using a trim-potentiometer, accessed through the rear-panel of the switch-box.

14.10.7. Reading Input Voltages

The analogue inputs are used to determine whether an SAM switch closure has occurred, as well as to read the battery voltage. Function readInputVolts(*int* iInput#) returns the conversion value of the specified input.

Input#	Device Read	Micro Input
0	Battery Voltage	AN0
1	Top row switches	A,B,C,D,E,F,G,H,I AN1
2	Middle row switches	A,B,C,D,E,F,G,H,I AN2
3	Bottom row switches	A,B,C,D,E,F,G,H,I AN3

The A/D converter has 8 channels, of which only 4 are utilised in this design. Providing 10 bit resolution, conversion results are stored in two 8 bit registers, ADRESH and ADRESL. This application will only require 8 bit resolution (256 levels), and therefore only the most significant 8 bits are used. This provides a voltage resolution of 12.8906mV. A 'left-justify' configuration feature is offered by Microchip, enabling the 8 most significant bits in the result to be shifted into the ADRESH register.

14.10.8. Conversion Time

Stabilisation time is required for the Analogue to Digital converter to charge the input capacitance after a channel is changed. Peatman (Peatman, pg. 138) states that the source resistance should be less than $2k\Omega$. Due to power consumption concerns, the source resistance of this design is a maximum of $22k\Omega$. However, sufficient acquisition delay will be provided to ensure that the holding capacitor charges fully. This minimum time is determined in the calculation below.

Time required to acquire the sample is given by:

$$T_{acq} = \text{Amplifier Settling Time} + \text{Holding Capacitor Charge Time} + \text{Temperature Coefficient}$$

Where:

$$C_{HOLD} = 120 \text{ pF}$$

$$T_{amp} = 2 \mu\text{S}$$

$$R_s = 22 \text{ k} \text{ (maximum source impedance, with no switch pressed)}$$

$$\text{Conversion Error} = 1/2 \text{ LSB}$$

$$V_{DD} = 3.3\text{V}$$

$$R_{ss} = 11\text{K}$$

$$\text{Temperature} = 50^\circ\text{C} \text{ (system max.)}$$

Holding Capacitor Charge Time:

$$\begin{aligned} T_c &= -C_{hold} (R_{ic} + R_{ss} + R_s) \ln(1/2047) \\ &= -120\text{pF} (1\text{K} + 11\text{K} + 22\text{k}) (-7.6241) \\ &= 31\mu\text{S} \end{aligned}$$

Temperature Coefficient:

$$\begin{aligned} T_{\text{coeff}} &= [(\text{Temp} - 25^{\circ}\text{C}) (0.05\mu\text{S}/^{\circ}\text{C})] \\ &= (50 - 25) (0.05 \times 10^{-6}) \\ &= 1.25\mu\text{S} \end{aligned}$$

Acquisition time:

$$\begin{aligned} T_{\text{acq}} &= T_{\text{amp}} + T_{\text{c}} + T_{\text{coeff}} \\ &= 2\mu\text{S} + 31\mu\text{S} + 1.25\mu\text{S} \\ &= \mathbf{34.25\mu\text{S}} \end{aligned}$$

A minimum delay, set by global constant ACQUISITION_TIME, will be provided between the channel selection, and the start of conversion. An initial value of 120uSeconds will be used.

14.10.9. Reading SAM Selection Switches

The switchbox holds 27 ‘SAM-selection’ switches, arranged in three rows of 9 switches each.

Row	Switch	Micro Input	Row#
Top Row	A,B,C,D,E,F,G,H,I	AN1	1
Middle Row	A,B,C,D,E,F,G,H,I	AN2	2
Bottom Row	A,B,C,D,E,F,G,H,I	AN3	3

Each switch, on closure, shorts a resistive ladder to ground, producing a different voltage at the analogue input according to which switch was pressed.

The main() routine loops, scanning the three switch rows with the getSwitch(int iRow#) function. Given the Row number, this uses readInputVolts(int iInput#) to read the analogue voltage on the appropriate analogue input. The input voltage is then compared to each of the 10 possible voltage ranges using function getRange(int iVolts). The returned Range is used to determine which switch was pressed.

When the switch is pressed, a switch code (‘BTxy’) is sent to the Host. When released, the switch down time (mSecs) is sent as a 5 digit string.

Debouncing is implemented in main() by examining the giSwitchDownTime global. If this is too short, switch bounce is deemed to have occurred, and an error message 'ER04' is sent in place of the duration.

The five significant user-button interactions which may occur are as follows:

1. *One button is pressed:* the getSwitch() function returns the number of the button, a digit from 0 (leftmost switch) to 8 (rightmost switch).
2. *No button has been pressed:* the full 3.3V will be read, and the getSwitch() function returns a flag value (OPEN).
3. *More than one button is pressed:* Regarded as a user error. However, this cannot be detected, and only the left-most switch of the group will be returned as in 1 above.
4. *A button is held down:* There is no typematic repeat key sent.
5. *A button is pressed but contact bounce occurs:* main() rejects switch-down durations less than 5mSecs.

14.10.10. Resistor Ladder Values

Resistors values were calculated to provide maximum separation between values, assuming a range of 0 to 3.3v. Values were calculated via Ohm's law and the closest available preferred available resistor values were chosen to suit. Resistors are all 1% tolerance. The Figure 409 illustrates calculated voltages into the microcontroller as each of the buttons on a row is pressed. Buttons are lettered A to I from left to right.

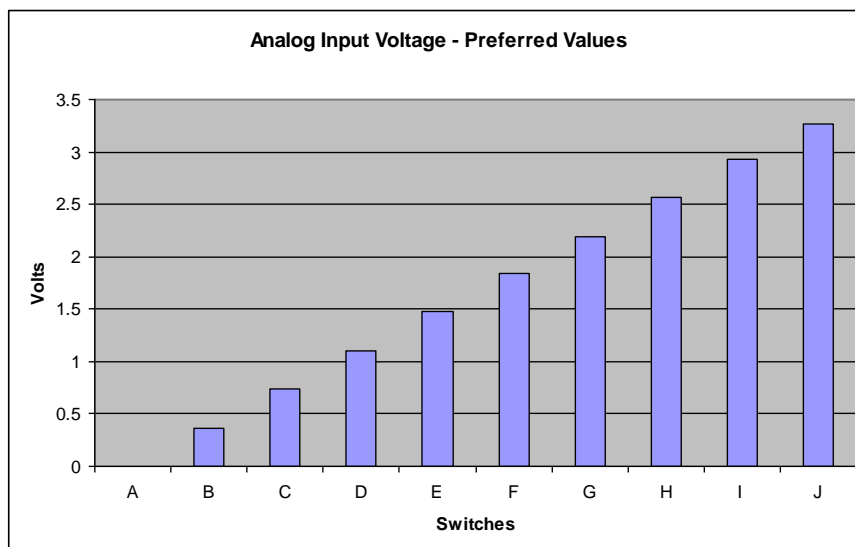

Figure 409: Calculated nominal voltage (using preferred value resistors)

Table 29 Resistor Ladder Values

Resistor	Calculated Value	Preferred Value	% Voltage Error
Ra	22000	22000	0
Rb	2750	2700	1.6194332
Rc	3536	3600	-0.1766784
Rd	4714	4700	0
Re	6600	6800	-0.6281407
Rf	9900	10000	-0.4819277
Rg	16500	16000	0.15197568
Rh	33000	33000	0.0578369
Ri	99000	100000	-0.0503018
Rj	-	O/C	0

14.10.11. Determination of Range

Only ten voltage ranges are possible at the analogue input to the microcontroller.

These are listed in Table 30:

Table 30: Voltage Ranges

A	0	0	0.180364372	A
B	0.180364372	0.360728745	0.54767886	B
C	0.54767886	0.734628975	0.917314488	C
D	0.917314488	1.1	1.287939698	D
E	1.287939698	1.475879397	1.659024036	E
F	1.659024036	1.842168675	2.019412605	F
G	2.019412605	2.196656535	2.380919361	G
H	2.380919361	2.565182186	2.74999552	H
I	2.74999552	2.934808853	3.117404427	I
NONE	3.117404427	3.3	3.3	NONE

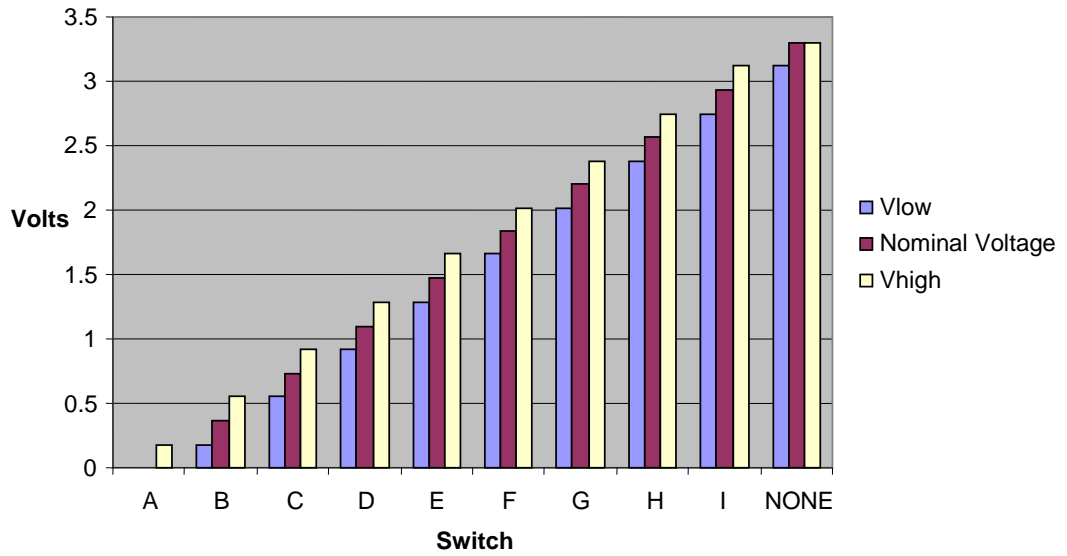

Figure 410: Voltage ranges for switches

Because only 8 bit resolution is being used, input to the analogue switch inputs will be limited to 256 discrete levels. Rounding the Vlow thresholds up provides the integer threshold voltages for each range (see Table 31):

Table 31: Rounded Integer Threshold Voltage Ranges for Switches

Range	Vlow	Vquant Low	Rounded Vqlow
A	0	0	0
B	0.180364372	13.99190283	14
C	0.54767886	42.48660248	43
D	0.917314488	71.16136631	72
E	1.287939698	99.91289782	100
F	1.659024036	128.7000464	129
G	2.019412605	156.6574627	157
H	2.380919361	184.7016231	185
I	2.74999552	213.3329858	214
NONE	3.117404427	241.8350101	242

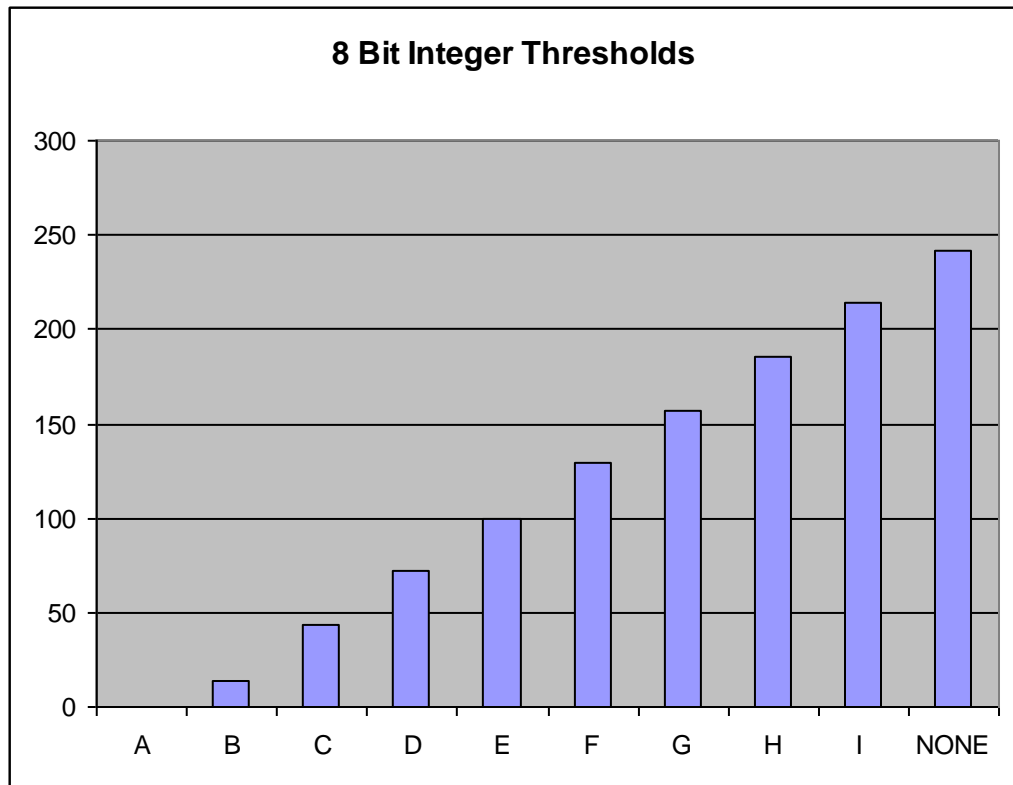

Figure 411: Rounded integer threshold ranges for switches

14.10.12. SAM Switch Duration

When SAM switches are pressed, the down-time is recorded, and upon release, the number of milliseconds elapsed is transmitted to the host.

Function `getSwitch()` enables `Timer0` when a valid switch press is detected. This timer is initialised by `initTimer0()` to overflow each millisecond. Each overflow trips the interrupt routine `ISR()`, and global `giSwitchDownTime` is incremented. When the switch is released, the timer is stopped, and `sendSwitchDownTime()` transmits the duration in milliseconds.

By experiment it was found that most button depressions tend to be in the region of 50 to 200mSeconds. Initial attempts resulted in an average error of $\pm 3.45\%$ over the full range (40mSecs to 2550 mSecs), but with significant errors (as much as $\pm 43\%$) and variance in the region of interest. This was improved by reducing overheads

associated with debouncing, as well as through the use of calibration correction (see Figure 412).

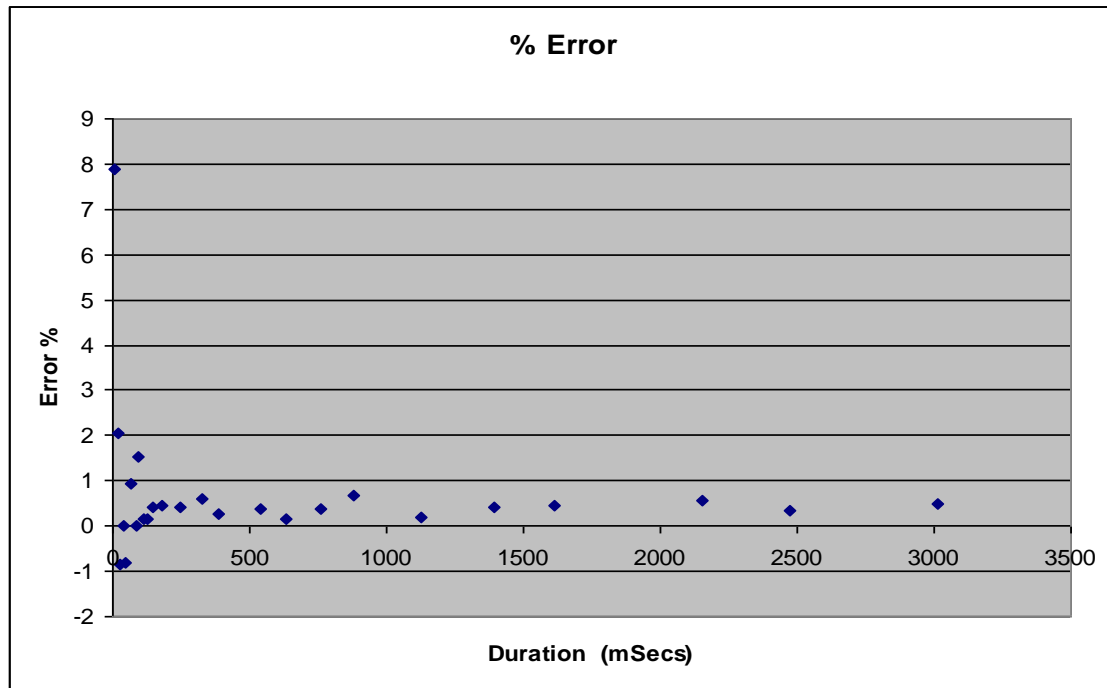

Figure 412: Button duration - corrected errors

14.10.13. **Communications**

The switchbox employs RS-232 over a straight-through cable at 9600bps, 8 bits, no parity, 1 stop bit. Two RJ-45 connectors, wired in parallel, are provided on each side of the switchbox to facilitate left or right mounting of the switchbox. In addition, tracks are provided on the PCB for mounting two right-angle DB-9 connectors. However, as these had exposed metal parts, it was decided not to install them.

The device used for interfacing provides RS-232 compatible $\pm 9V$ signals using a low-current ICL322&E interface chip. This operates on 3.3V, and develops 232 levels using capacitors and charge-pumps.

14.10.14. **Protocol**

The protocol is half-duplex (communication in both directions, but not simultaneously). Command strings characters must be 8 bit ASCII, and must be capitalised. Unrecognisable commands are ignored.

The protocol requires that commands be 4 characters in length, and thus it is possible that some communications error may leave the switchbox waiting for the rest of a command. For critical applications, the Host may periodically check for this by sending a 'PING' request. If no 'PONG' response is detected, the communications may have failed. The Host may then attempt to re-synch by transmitting a succession of up to three 'P' characters, until a 'PONG' response is received.

The command queue ring buffer can process up to ten consecutive commands. Sending more than this will result in overwriting of the buffer contents.

14.10.15. **Command Set**

Commands are divided into Output (from the switchbox to the Host) and Input (received by the switchbox from the Host). All commands must be capitals, and no more than 4 characters long.

14.10.16. **Output Commands**

BTxy Button on row x, column y is ON
where x is a digit between 1 and 3 inclusive
and y is an alpha character from A to I inclusive

This command informs the Host that the specified SAM selection button has been pressed. In a typical application, the Host PC application would record this code, and returns a control message to the switchbox, causing the corresponding LED to light. The command is sent when the button is released.

If the xy characters are out of range, an error code (ER02) will be returned.

wxyz Duration of button-press in 1 millisecond increments (0000 to 9999)

When SAM switches are pressed, the duration of the down-time is measured to a resolution of 1mSeconds. This measurement is sent to the host after the switch is released.

OKDN Next Slide' button is ON

This command informs the Host that the red 'Next Slide' button has been pressed.

PONG Confirmation that device is present and operational

The response to a Host 'PING' command. Indicates that the device and communication link are operational.

Bxyz Battery capacity is currently xyz percent
where xyz is a three digit number between 0 and 100 (full capacity)

The response to a Host request for battery level 'BATL'. Provides an estimate of capacity.

14.10.17. **Input Commands**

CLRZ Clear all LEDS
All twenty-seven SAM LEDS are turned off.

CLR1 Clear ROW 1 LEDS (top row)
All nine LEDS on this row are turned off.

CLR2 Clear ROW 2 LEDS (middle row)
All nine LEDS on this row are turned off.

CLR3 Clear ROW 3 LEDS (bottom row)
All nine LEDS on this row are turned off.

OKON	'Next Slide' button LED turned on
OKOF	'Next Slide' button LED turned off
AUxx	Audio pitch set to one of 99 frequencies between 100 hz and 4,700hz where xx is a two digit number between 0 and 99
AUON	Audio ON Turns the audio speaker on. The tone produced will be at the frequency set by the previous AUxx command. On power-up, this will be 2300Hz.
AUOF	Audio OFF
BATL	Request battery level Initiates measurement of the battery voltage. The switchbox will respond with a Bxyz command.
LTxy	Set LED on row x and column y ON where x is a digit between 1 and 3 inclusive and y is an alpha character from A to I inclusive
PING	Request confirmation of device present The switchbox will respond with a 'PONG'
RSET	Reset device Initialised to start-up state. All LEDs will be turned off. The audio speaker will be turned off, and the audio frequency setting returned to 2300Hz. The 'Next Slide' LED will flash 3 times.
Sxyz	Generate a number of synch pulses from 000 to 999 Synch pulses are output to the 3.5mm connector on the back of the instrument.

15.0 References

- Abe, S. (2010). *Support Vector Machines for Pattern Classification*. (S. Singh, Ed.) (2nd ed., p. 473). Kobe, Japan: Springer.
- Abello, J., & Pardalos, P. (2002). *Handbook of Massive Data Sets*. San Francisco: Springer.
- Abercrombie, H. C., Kalin, N. H., Thurow, M. E., Rosenkranz, M. A., & Davidson, R. J. (2003). Cortisol Variation in Humans Affects Memory for Emotionally Laden and Neutral Information. *Behavioral Neuroscience*, *117*(3), 505–516. doi:10.1037/0735-7044.117.3.505
- Achaibou, A., Pourtois, G., Schwartz, S., & Vuilleumier, P. (2008). Simultaneous recording of EEG and facial muscle reactions during spontaneous emotional mimicry. *Neuropsychologia*, *46*(4), 1104–13. doi:10.1016/j.neuropsychologia.2007.10.019
- Addison, P. S. (2005). Wavelet Transforms and the ECG: a Review. *Physiological Measurement*, *26*(5), 0. doi:10.1088/0967-3334/26/5/R01
- Afzal, S., & Robinson, P. (2009). Natural affect data—Collection & annotation in a learning context. *Affective Computing and Intelligent Interaction and Workshops, 2009. ACII 2009. 3rd International Conference on* (pp. 1–7). IEEE.
- Aharonson, V., Amir, N., Andre, E., Batliner, A., Caridakis, G., Cerekovic, A., Devillers, L., et al. (2006). *D4f: Mid-term Report on Signal to Emotion Exemplar Progress. Contract* (pp. 1–32). Ahtens.
- Aizerman, A. (1964). Theoretical foundations of the potential function method in pattern recognition learning. *Automation and remote* .
- Akselrod, S., & Oz, O. (1997). Autonomic response to change of posture among normal and mild-hypertensive adults: investigation by time-dependent spectral analysis. *Journal of the Autonomic* .
- Alfaouri, M., & Daqrouq, K. (2008). ECG Signal Denoising By Wavelet Transform Thresholding. *American Journal of Applied Sciences*, *5*(3), 276–281.
- Amoroso, E., Bell, F., & Rosenberg, H. (1954). The Relationship of the Vasomotor and Respiratory Regions in the Medulla Oblongata of the Sheep. *The Journal of Physiology*, *126*, 86–95.
- Anant, K., Dowla, F., & Rodrigue, G. (1995). Vector Quantization of ECG Wavelet Coefficients. *Signal Processing Letters, IEEE*, *2*(7), 129 – 131.
- Anant, K. S. (1993). Detection of the Electrocardiogram P-wave using Wavelet Analysis. *International Journal of Neural Systems*, *14*(2), 87–90.

- Anastassiou, C. A., Perin, R., Markram, H., & Koch, C. (2011). Ephaptic Coupling of Cortical Neurons. *Nature Neuroscience*, *14*(2), 217–223.
- Andraão, R. V., & Boudy, J. (2007). Combining Wavelet Transform and Hidden Markov Models for ECG Segmentation. *EURASIP Journal on Advances in Signal Processing*, *2007*, 1–8. doi:10.1155/2007/56215
- Angelica, M., Gül, V., & Kremer, E. O. (2010). Exploring the factors affecting emotion elicitation. *Proceedings of the 7th International Conference on Design & Emotion*, *7*, 182–187.
- Arch, J. J., & Craske, M. G. (2006). Mechanisms of Mindfulness: Emotion Regulation Following a Focused Breathing Induction. *Behaviour Research and Therapy*, *44*(12), 1849–58.
- Arnold, M. B. (1960). *Emotion and Personality*. New York: Columbia University Press.
- Augustyniak, P. (2006). Adaptive Wavelet Discrimination of Muscular Noise in the ECG. *Computers in Cardiology*, 481–484.
- Averill, J. R. (1985). The Social Construction of Emotion: With Special Reference to Love. *The social construction of the person*, 89–109.
- Averill, J. R., & Nunley, E. P. (1988). Grief as an Emotion and as a Disease: A Social-constructionist Perspective. *Journal of Social Issues*, *44*(3), 79–95.
- Axelrod, L. A. (2009). *Emotional recognition in computing*. Computing. Brunel University.
- Axelrod, L., & Hone, K. (2004). Smoke and Mirrors: Gathering user Requirements for Emerging Affective Systems. *Information Technology Interfaces, 2004. 26th International Conference on, 1*, 323–328. doi:10.1109/ITI.2004.241871
- Axisa, F., Dittmar, A., Delhomme, G., & Cedex, V. (2003). Smart Clothes for the Monitoring in Real Time and Conditions of Physiological, Emotional and Sensorial Reactions of Human. *Engineering in Medicine and Biology Society, 2003. Proceedings of the 25th Annual International Conference of the IEEE, 4*, 3744–3747.
- Axisa, F., Gehin, C., Delhomme, G., Collet, C., Robin, O., & Dittmar, A. (2004). Wrist Ambulatory Monitoring System and Smart Glove for Real Time Emotional, Sensorial and Physiological Analysis. *Engineering in Medicine and Biology Society, 2004. IEMBS '04. 26th Annual International Conference of the IEEE (Vol. 1, pp. 2161–216)*. IEEE. doi:10.1109/IEMBS.2004.1403632
- Azevedo, F. M., Amadio, A. C., Alves, N., Catelli, D. S., Filho, R. F. N., Raquel, A., Azevedo^a, N., et al. (2009). A Multivariate Analysis of Electromyography Signal Frequency Parameters on Characterization Process of Local Fatigue Muscle. *European Journal of Applied Physiology*.

- Azevedo, T., Volchan, E., Imbiriba, L., Rodrigues, E., Oliveira, J., Oliveira, L., Lutterbach, L., et al. (2005). A freezing-like posture to pictures of mutilation. *Psychophysiology*, *42*(3), 255–260.
- Baayen, R. (2008). *Analyzing linguistic data: A practical introduction to statistics using R*. Cambridge, MA: Cambridge University Press.
- Backs, R. W., da Silva, S. P., & Han, K. (2005). A comparison of younger and older adults' self-assessment manikin ratings of affective pictures. *Experimental aging research*, *31*(4), 421–40. doi:10.1080/03610730500206808
- Badal, D. Z. Z. (1993). Neural network recognition of human face images stored in the database. *Computers and Communications, 1993., Twelfth Annual International Phoenix Conference on* (pp. 552–558). IEEE. doi:10.1109/PCCC.1993.344529
- Bailey, N. (1756). *An Universal Etymological English Dictionary*. London: [lack of historical record concerning publisher].
- Ball, G., & Breese, J. (1999). Modeling the Emotional State of Computer Users. *Workshop on 'Attitude, Personality and Emotions in User-Adapted Interaction* (pp. 1–5). Redmond.
- Banerjee, A., Merugu, S., Inderjit, D., & Joydeep, G. (2005). Clustering with Bregman Divergences. *Journal of Machine Learning Research*, *6*, 1705–1749.
- Bank, A. A., & Koninklijke. (2009). Mirror of Emotions. *Electronics*.
- Baratta, R., Solomonow, M., Zhou, B. H., Letson, D., Chuinard, R., & D'Ambrosia, R. (1988). Muscular Coactivation: The Role of the Antagonist Musculature in Maintaining Knee Stability. *The American Journal of Sports Medicine*, *16*(2), 113–122. doi:10.1177/036354658801600205
- Barreto, A., & Zhai, J. (2003). Physiologic Instrumentation for Real-time Monitoring of Affective State of Computer Users. *WSEAS - Transactions on Circuits and Systems*, *3*, 496–501.
- Bass, G., & Shouldice, R. (2002). Electrocardiography. From Bench To Bedside. *The Engineers Journal*, *3*(5), 47–49.
- Bates, D., & Sarkar, D. (2007). lme4: Linear mixed-effects models using S4 classes.
- Baumgartner, T., Esslen, M., & Jäncke, L. (2006). From emotion perception to emotion experience: emotions evoked by pictures and classical music. *International journal of psychophysiology : official journal of the International Organization of Psychophysiology*, *60*(1), 34–43. doi:10.1016/j.ijpsycho.2005.04.007

- Bayes, T. (1763). An Essay towards solving a Problem in the Doctrine of Chances. By the late Rev. Mr. Bayes, FRS communicated by Mr. Price, in a letter to John Canton, AMFRS. *Philosophical Transactions (1683-1775)*.
- Bayes, T., & Barnard, G. A. (1958). Studies in the History of Probability and Statistics: IX. Thomas Bayes's Essay Towards Solving a Problem in the Doctrine of Chances. *Biometrika*, 45(3/4), 293–315.
- Bazett, H. C. (1920). An Analysis of the Time-Relations of Electrocardiograms. *Heart*, 7, 353–370.
- Bechara, A. (2004). The role of emotion in decision-making: Evidence from neurological patients with orbitofrontal damage. *Brain and cognition*, 55(1), 30–40.
- Bechara, A., Damasio, H., & Damasio, A. R. (2000). Emotion, decision making and the orbitofrontal cortex. *Cerebral cortex*, 10(3), 295–307.
- Ben-Masaud, A., Solomonow, D., Davidson, B., Zhou, B. H., Lu, Y., Patel, V., & Solomonow, M. (2009). Motor Control of Lumbar Instability Following Exposure to Various Cyclic Load Magnitudes. *European spine journal : official publication of the European Spine Society, the European Spinal Deformity Society, and the European Section of the Cervical Spine Research Society*, 18(7), 1022–34. doi:10.1007/s00586-009-0952-6
- Benadada, K., Chaffar, S., & Frasson, C. (2008). Using Tutorial Actions to Improve the Learner's Emotional State. *World Conference on E-Learning in Corporate, Government, Healthcare, and Higher Education (ELEARN)* (pp. 2094–2101). Las Vegas, Nevada.
- Bendixen, H. H., Egbert, L. D., Hedley-Whyte, J., Laver, M. B., & H., P. (1965). *Respiratory Care*. St. Louis.
- Bengio, Y., & Grandvalet, Y. (2004). No Unbiased Estimator of the Variance of k-fold Cross-Validation. *The Journal of Machine Learning Research*, 5, 1089–1105.
- Benitez, D., Gaydecki, P., Zaidi, A., & Fitzpatrick, A. (2000). A new QRS Detection Algorithm Based on the Hilbert Transform. *Computers in Cardiology 2000*, 27, 379–382.
- Bennett, C., Baird, A., Miller, M. B., & Wolford, G. L. (2009). Neural correlates of interspecies perspective taking in the post-mortem Atlantic Salmon: an argument for multiple comparisons correction. *NeuroImage*, 47(2), S125.
- Bersak, D., Mcdarby, G., Augenblick, N., McDarby, P., McDonnell, D., & MDdonald, B. (2001). Intelligent Biofeedback using an Immersive Competitive Environment. *Proceedings of UBIComp 2001 Workshop on Ubiquitous Gaming* (pp. 1–6).

- Berson, A. S., Cantwell, S., David, Y., Arthur Eddy, J., Eggleston, J., Gettman, K., Kim, J., et al. (2010). ANSI/AAMI ES60601-1:2005 Medical electrical equipment– Part 1: General requirements for basic safety and essential performance. *AAMI Standards and Recommended Practices*, (ES60601-1).
- Bettadapura, V. K. (2009). *Face Expression Recognition and Analysis: The State of the Art*. columbia.edu (pp. 1–27). Atlanta.
- Bindu, M. H. (2007). Cognitive Model - Based Emotion Recognition From Facial Expressions. *Image (Rochester, N.Y.)*, (Ciisp), 351–356.
- Bindu, M. H. H., Gupta, P., & Tiwary, U. S. S. (2007). Cognitive Model - Based Emotion Recognition From Facial Expressions For Live Human Computer Interaction. *Computational Intelligence in Image and Signal Processing, 2007. CIISP 2007. IEEE Symposium on* (pp. 351–356). IEEE. doi:10.1109/CIISP.2007.369194
- Bitter, N. L., Clisby, E. F., Jones, M. A., Magarey, M. E., Jaberzadeh, S., & Sandow, M. J. (2007). Relative Contributions of Infraspinatus and Deltoid During External Rotation in Healthy Shoulders. *Journal of Shoulder and Elbow Surgery*.
- Black, C., & Huang, N. (2001). Effect of nicotine on vasoconstrictor and vasodilator responses in human skin vasculature. *American Journal of*.
- Blanchard, E, Chalfoun, P., & Frasson, C. (2007). Towards Advanced Learner Modeling: Discussions on Quasi Real-time Adaptation with Physiological Data. *Advanced Learning Technologies, 2007. ICALT 2007. Seventh IEEE International Conference on* (pp. 809–813). IEEE. doi:10.1109/ICALT.2007.264
- Blanchard, Emmanuel, Chalfoun, P., & Frasson, C. (2007). Towards Advanced Learner Modeling: Discussions on Quasi Real-time Adaptation with Physiological Data. *Respiration, (Icalt)*, 3–7.
- Bland, M. (2000). *An Introduction to Medical Statistics (Oxford Medical Publications)* (p. 405). New York: Oxford University Press, USA.
- Bo, C., & Guang-Yuan, L. (2008). Emotion recognition from surface EMG signal using wavelet transform and neural network. *Jisuanji Yingyong/ Journal of Computer Applications*, 2.
- Bohbot, A. (2010). Olfactory Ensheathing Glia Transplantation Combined with Laserpuncture in Human Spinal Cord Injury: Results Measured by Electromyography Monitoring. *Cell Transplantation*, 19, 179–184.
- Bonarini, A., Mainardi, L., Matteucci, M., Tognetti, S., & Colombo, R. (2008). Stress Recognition in a Robotic Rehabilitation Task. *Proc. of "Robotic Helpers: User Interaction, Interfaces and Companions in Assistive and Therapy Robotics", a Workshop at ACM/IEEE HRI 2008,, 1*.

- Bortolan, G. (2006). Algorithmic Testing for QT Interval Measurement. *Computers in Cardiology*, 33, 365 – 368.
- Boucsein, W. (1988). Psychophysiological investigation of stress induced by temporal factors in human-computer interaction. In M. Frese, E. Ulich, & D. Wolfgang (Eds.), *Psychological issues of human-computer interaction in the work place* (pp. 163 – 181). Amsterdam: North-Holland Publishing Co.
- Bouhuys, A. L., Jansen, C. J., & van den Hoofdakker, R. H. (1991). Analysis of Observed Behaviors Displayed by Depressed Patients During a Clinical Interview: Relationships Between Behavioral Factors and Clinical Concepts of Activation. *Journal of affective disorders*, 21(2), 79–88.
- Boulogne, G.-B. D. de. (1990). *The Mechanism of Human Facial Expression (Studies in Emotion and Social Interaction)* (p. 308). Cambridge, MA: Cambridge University Press.
- Boxtel, A. V. (2010). Facial EMG as a Tool for Inferring Affective States. *Signals*, 2010(Figure 3), 104–108.
- Bradley, M M, Codispoti, M., Sabatinelli, D., & Lang, P. J. (2001). Emotion and Motivation II: Sex Differences in Picture Processing. *Emotion (Washington, D.C.)*, 1(3), 300–319.
- Bradley, M., Codispoti, M., Sabatinelli, D., & Lang, P. (2001). Emotion and Motivation II: Sex Differences in Picture Processing. *Emotion*, 1(3), 300–319.
- Bradley, M., & Lang, P. (1999). *Affective Norms for English Words (ANEW): Instruction Manual and Affective Ratings*. University of Florida: The Center for the Study of Emotion and Attention. Florida.
- Bradley, M., & Lang, P. (2007). *Affective Norms for English Text (ANET): Affective ratings of text and instruction manual. Technical Report. D-1, University of Florida, Gainesville, .*
- Bradley, M., Codispoti, M., Cuthbert, B., Lang, P., & Sabatinelli, D. (2001). Emotion and Motivation I: Defensive and Appetitive Reactions in Picture Processing. *Emotion*, 1(3), 276–298. doi:10.1037//1528-3542.1.3.276
- Bradley, M., Miccoli, L., Escrig, M., & Lang, P. (2008). The Pupil as a Measure of Emotional Arousal and Autonomic Activation. *Psychophysiology*, 45(4), 602–607.
- Bradley, M., & Lang, P. (1994). Measuring Emotion: the Self-Assessment Manikin and the Semantic Differential. *Journal of Behavior Therapy and Experimental Psychiatry*, 25(1), 49–59.

- Bradley, Margaret M., Lang, P. J., Lang, Coan, J., & Allen, J. (2007). The International Affective Picture System (IAPS) in the Study of Emotion and Attention. In James A Coan & J. J. Allen (Eds.), *Handbook of Emotion Elicitation and Assessment* (1st ed., pp. 29–46). New York: Oxford University Press.
- Branco, P. (2003). Studying Emotional Interaction. *Computer Graphik Topics*, 3(15), 9–10.
- Branco, P., & Encarnacao, L. M. (2004). Affective Computing for Behavior-Based UI Adaptation. *Proc. of Intelligent User Interface2004 Con* (pp. 1–4).
- Bregman, L. M. (1967). The relaxation method of finding the common point of convex sets and its application to the solution of problems in convex programming. *USSR Computational Mathematics and Mathematical Physics*, 7(3), 200–217. doi:10.1016/0041-5553(67)90040-7
- Breiman, L. (2001). Random Forests. *Machine Learning*, 45(1), 5–32. doi:10.1023/A:1010933404324
- Brentson, G., & Cacioppo, J. (2007). Integrative physiology: Homeostasis, allostasis, and the orchestration of systemic physiology. *Handbook of Psychophysiology*.
- Broadbent, E., MacDonald, B., Jago, L., Juergens, M., & Mazharullah, O. (2007). Human reactions to good and bad robots. *Intelligent Robots and Systems, 2007. IROS 2007. IEEE/RSJ International Conference on* (pp. 3703–3708). doi:10.1109/IROS.2007.4398982
- Broca, P. (1878). Anatomie Comparée Des Circonvolutions Cérébrales: Le Grand Lobe Limbique. *Rev. Anthropol*, 1, 385–498.
- Bromberg, W., & Schilder, P. (1934). Olfactory imagination and olfactory hallucinations: an experimental and clinical study of the sense of smell in normal and in psychotic persons. *Archives of Neurology and Psychiatry*, 32(3), 467.
- Brookes, M. (2000). Transactions Briefs *IEEE Transactions On Circuits And Systems—II: Analog and Digital Signal Processing*, 47(9), 930–935.
- Brooks, D. H., Krim, H., Pesquet, J. C., & Macleod, R. S. (1996). Best Basis Segmentation of ECG Signals using Novel Optimality Criteria. *Acoustics, Speech and Signal Processing, 1996. ICASSP 1996. IEEE International Conference on* (pp. 2750–2753). Atlanta.
- Brosschot, J., Dijk, E. V., & Thayer, J. (2007). Daily worry is related to low heart rate variability during waking and the subsequent nocturnal sleep period. *International Journal of* .
- Brunyé, T. T., Ditman, T., Mahoney, C. R., & Taylor, H. A. (2011). Better You than I: Perspectives and Emotion Simulation during Narrative Comprehension. *Journal of Cognitive Psychology*, (In press).

- Buckley, K. (2007). Biomedical Signal Processing - Filtering. *Signal Processing*. Villanova University, ECE Department.
- Burges, C., & Scholkopf, B. (1997). *Improving the Accuracy and Speed of Support Vector Machines*. *Advances in neural information processing* (pp. 1–7).
- Burns, J. (2006). Arousal of negative emotions and symptom-specific reactivity in chronic low back pain patients. *Emotion*.
- Busso, C., Deng, Z., Grimm, M., Neumann, U., & Narayanan, S. (2007). Rigid Head Motion in Expressive Speech Animation: Analysis and Synthesis. *Audio, Speech, and Language Processing, IEEE Transactions on [see also Speech and Audio Processing, IEEE Transactions on]*, 15(3), 1075–1086.
doi:10.1109/TASL.2006.885910
- Cacioppo, J T, Petty, R. E., Losch, M. E., & Kim, H. S. (1986). Electromyographic Activity over Facial Muscle Regions can Differentiate the Valence and Intensity of Affective Reactions. *Journal of Personality and Social Psychology*, 50(2), 260–8.
- Cacioppo, J. T., Bush, L. K., & Tassinary, L. G. (1992). Microexpressive Facial Actions as a Function of Affective Stimuli: Replication and Extension. *Personality and Social Psychology Bulletin*, 18(5), 515–526.
doi:10.1177/0146167292185001
- Cacioppo, J.T. (2009). Introduction: Emotion and Health. In R. Davidson, K. Scherer, & H. Goldsmith (Eds.), *Handbook of Affective Sciences* (1st ed., pp. 1047–1052). New York: Oxford University Press.
- Cacioppo, J.T., & Lang, P. J. (1998). Eliciting Affect Using the International Affective Picture System: Trajectories through evaluative space. *Personality and Social Psychology*, 24, 855–879.
- Cacioppo, John T., Martzke, J. S., Petty, R. E., & Tassinary, L. G. (1988). Specific forms of facial EMG response index emotions during an interview: From Darwin to the continuous flow hypothesis of affect-laden information processing. *Journal of Personality and Social Psychology*, 54(4), 592–604.
doi:10.1037/0022-3514.54.4.592
- Campbell, D., & Fiske, D. (1959). Convergent and Discriminant Validation by the Multitrait-Multimethod Matrix. *Psychological Bulletin*, 56(2), 282–289.
- Campbell, D. T., Stanley, J. C., & Gage, N. L. (1963). *Experimental and quasi-experimental designs for research*. Boston: Houghton Mifflin Boston.
- Cannon, W. (1927). The James-Lange theory of emotions: A critical examination and an alternative . *The American Journal of Psychology*, 39(1/4), 106–124.

- Cardinal, R. N., Parkinson, J. A., Hall, J., & Everitt, B. J. (2002). Emotion and motivation: the role of the amygdala, ventral striatum, and prefrontal cortex. *Neuroscience and biobehavioral reviews*, 26(3), 321–352.
- Caruana, R., Karampatziakis, N., & Yessenalina, A. (2008). An empirical evaluation of supervised learning in high dimensions. *Proceedings of the 25th International Conference on Machine Learning*, 25(1).
- Caruana, R., & Niculescu-Mizil, A. (2006). An Empirical Comparison of Supervised Learning Algorithms. *International Conference on Machine Learning.*, 23(1), 161–168.
- Ceschi, G., & Scherer, K. (2003). Children's ability to control the facial expression of laughter and smiling: Knowledge and behaviour. *Cognition & Emotion*, 17(3), 385–411. doi:10.1080/02699930143000725
- Chan, A. D. C., & Green, G. C. (2007). Myoelectric Control Development Toolbox. *30th Conference of the Canadian Medical & Biological Engineering Society*, 30.
- Chan, F. H., Yang, Y. S., Lam, F. K., Zhang, Y. T., & Parker, P. a. (2000). Fuzzy EMG Classification for Prosthesis Control. *IEEE transactions on rehabilitation engineering : a publication of the IEEE Engineering in Medicine and Biology Society*, 8(3), 305–11.
- Chang, C.-C., & Lin, C.-J. (2011). LIBSVM: A library for support vector machines. *ACM Transactions on Intelligent Systems and Technology*.
- Chateau, N., Pierre-marzin, A., & Mersiol, M. (2005). AMUSE : A Tool for Evaluating Affective Interfaces. *Technology*, 2–5.
- Chazal, P, Celler, B. G., & Reilly, R. B. (2000). Using Wavelet Coefficients for the Classification of the Electrocardiogram. *Biomedical Engineering*, (July), 2–5.
- Chazal, P, & Reilly, R. B. (2000a). A Comparison of the Use of Different Wavelet Coefficients for the Classification of the Electrocardiogram. *Pattern Recognition*, (September), 4–7.
- Chazal, P, & Reilly, R. B. (2000b). A Comparison of the ECG Classification Performance of Different Feature Sets. *Electrical Engineering*, (September).
- Chazal, Philip de, Penzel, T., & Heneghan, C. (2004). Automated Detection of Obstructive Sleep Apnoea at Different Time Scales using the Electrocardiogram. *Physiological Measurement*, 25(4), 967–983. doi:10.1088/0967-3334/25/4/015
- Chen, C. H. (1988). *Signal Processing Handbook*. (C. Chen, Ed.) (1st ed., p. p 531). Boca Raton: CRC Press.
- Chen, JJJ, & Shiavi, R. (1990). Temporal Feature Extraction and Clustering Analysis of Electromyographic Linear Envelopes in Gait Studies. *IEEE Transactions on Biomedical Engineering*, 37(3), 295–302.

- Chen, Jingjing, & Luo, Q. (2006). Research on e-learning system model based on affective computing. *Computer-Aided Industrial Design and Conceptual Design, 2006. CAIDCD '06*. (Vol. 7, pp. 1–4). IEEE.
doi:10.1109/CAIDCD.2006.329365
- Cherkassky, V., & Kilts, S. (2001). Comparison of Wavelet Thresholding Methods for Denoising ECG Signals. *Artificial Neural Networks—ICANN 2001 Proceedings* (pp. 625–630).
- Chesnokov, Y., Nerukh, D., & Glen, R. (2006). Individually adaptable automatic QT detector. *Computers in Cardiology, 2006* (pp. 337–340). IEEE.
- Choi, A., & Woo, W. (2005). Physiological sensing and feature extraction for emotion recognition by exploiting acupuncture spots. *Affective Computing and Intelligent Interaction*.
- Choppin, A. (2000). *EEG-Based Human Interface for Disabled Individuals: Emotion Expression with Neural Networks*. Emotion. Tokyo Institute of Technology.
- Christie, I. C. (2003). An Easily Implemented QRS Detection Algorithm in the Matlab Programming Language. *Language, 43*.
- Christov, I. I. (2006). Power-line interference elimination from ECG: dynamic evaluation of the linearity criterion. *Electrotechnika & Electronica, 34–39*.
- Clifford, G. D. (2006). ECG Statistics, Noise, Artifacts, and Missing Data. In G. D. Clifford, F. Azuaje, & P. Mcsharry (Eds.), *Advanced Methods and Tools for ECG Analysis*. Artech House Publishers.
- Clynes, M. (1989). *Sentic Cycles and Their Capacity to Transform*. *Sentics: The touch of emotions*. Avery Publishing Group.
- Clynes, Manfred. (1978). *Sentics: The Touch of the Emotions* (p. 273). New York: Anchor Press /Doubleday.
- Cnossen, F., Rothengatter, T., & Meijman, T. (2000). Strategic changes in task performance in simulated car driving as an adaptive response to task demands. *Transportation Research*.
- Coan, J.A., & Allen, J. J. B. (2007). *Handbook of Emotion Elicitation and Assessment*. (J.A. Coan & J. J. B. Allen, Eds.) (1st ed.). New York: Oxford University Press.
- Coelho, H., & Botelho, L. M. (1998). Adaptive Agents: Emotion Learning. *Paper presented at the 5th International Conference of the Society for Adaptive Behavior - Workshop: Grounding Emotions in Adaptive Systems* (pp. 19–24).
- Cohen, R. A., & Carolina, N. (1999). An Introduction to PROC LOESS for Local Regression. *Proceedings of the 24th SAS Users Group*.

- Colibazzi, T., Posner, J., Wang, Z., Gorman, D., Gerber, A., Yu, S., Zhu, H., et al. (2010). Neural systems subserving valence and arousal during the experience of induced emotions. *Emotion*, 10(3), 377–382.
- Committee EL/18/1. (1986). Approval and Test Specification - Electromedical Equipment - General Requirements. *Standards Association Of Australia*, (AS 3200).
- Correa, L. S., Laciari, E., Torres, A., & Jane, R. (2008). Performance evaluation of three methods for respiratory signal estimation from the electrocardiogram. *Engineering in Medicine and Biology Society, 2008. EMBS 2008. 30th Annual International Conference of the IEEE* (pp. 4760–4763). IEEE.
- Coulson, M. (2004). Attributing Emotion to Static Body Postures: Recognition Accuracy, Confusions, and Viewpoint Dependence. *Journal of nonverbal behavior*, 28(2), 117–139.
- Cram, J., Kasman, G. ., & Holtz, J. (1998). *Introduction to surface electromyography. 1998. Gaithersburg, Maryland: Aspen Publishers.*
- Creemers, W. (2010). Fast Median Filter. Retrieved from <https://sourceforge.net/projects/fastmedianfilt/>
- Creemers, Warren, & Hingston, P. (2010). Hardware Implementation of the Self Assessment Manikin. *Proceedings of the 7th International Conference on Design & Emotion*, 63–73.
- Critchley, H. D. H., Elliott, R., Mathias, C. J., & Dolan, R. J. (2000). Neural Activity Relating to Generation and Representation of Galvanic Skin Conductance Responses: A Functional Magnetic Resonance Imaging Study. *Journal of Neuroscience*, 20(8), 3033.
- Dale, P. (1986). *The Myth of Japanese Uniqueness*. New York: St Martin's Press.
- Dalgleish, T. (2004). The Emotional Brain. *Nature Reviews Neuroscience*, 5(7), 583–589.
- Daniels, J. W., Mole, P. A., Shaffrath, J. D., & Stebbins, C. L. (1998). Effects of Caffeine on Blood Pressure, Heart Rate, and Forearm Blood Flow During Dynamic Leg Exercise. *Journal of Applied Physiology*, 85(1), 154.
- Darwin, C. (1872). *The Expression of the Emotions in Man and Animals*. Chicago: University of Chicago Press.
- Darwin, C. (1998). *The Expression of the Emotions in Man and Animals; with an introduction, afterword, and commentaries by Paul Ekman*. NY: Oxford University. HarperCollins.

- Davidson, R., Scherer, K., & Goldsmith, H. (Eds.). (2009). Introduction: Personality. *Handbook of Affective Sciences* (1st ed., pp. 677–680). New York: Oxford University Press.
- Davidson, R. J., Sherer, K. R., & Goldsmith, H. H. (Eds.). (2009). *Handbook of Affective Sciences* (1st ed., p. 1224). New York: Oxford University Press, USA.
- Davies, D. L., & Bouldin, D. . (1979). A Cluster Separation Measure. *Pattern Analysis and Machine Intelligence, IEEE Transactions on* (pp. 224–227).
- Davis, J. I., Senghas, A., Brandt, F., & Ochsner, K. N. (2010). The effects of BOTOX Injections on Emotional Experience. *Emotion, 10*(3), 433–40.
doi:10.1037/a0018690
- De Chazal, P., Heneghan, C., Sheridan, E., Reilly, R., Nolan, P., & O'Malley, M. (2003). Automated processing of the single-lead electrocardiogram for the detection of obstructive sleep apnoea. *Biomedical Engineering, IEEE Transactions on, 50*(6), 686–696.
- De Gelder, B., Vroomen, J., Pourtois, G., & Weiskrantz, L. (1999). Non-conscious recognition of affect in the absence of striate cortex. *Neuroreport, 10*(18), 3759.
- De Silva, P. R., Osano, M., Marasinghe, A., Madurapperuma, A. P., Silva, P. R. D., & Laboratory, S. E. (2006). Towards Recognizing Emotion with Affective Dimensions Through Body Gestures. *Gesture, 269–274*.
- Delibasic, B., Jovanovic, M., Vukicevic1, M., Suknovic, M., & Obradovic, Z. (2011). Component-based decision trees for classification. *Intelligent Data Analysis, 5*.
- Demuth, H., Beale, M., & Hagan, M. (2010). *Neural Network Toolbox™ 6 User 's Guide. Network. Natick*.
- Derryberry, D., & Reed, M. A. (2009). Information Processing Approaches to Individual Differences in Emotional Reactivity. In R. Davidson, K. Scherer, & H. Goldsmith (Eds.), *Handbook of Affective Sciences* (1st ed., pp. 681–697). New York: Oxford University Press.
- Desmet, P. M. A. (2003). Measuring Emotions. In M. Blythe, K. Overbeeke, A. Monk, & P. Wright (Eds.), *Human-Computer Interaction Series,3, Funology: from usability to enjoyment* (3rd ed., Vol. 3 [Funolog, pp. 111–124). Dordrecht: Kluwer Academic Publishers.
- Deák, A., Csenki, L., & Révész, G. (2010). Hungarian ratings for the International Affective Picture System (IAPS): A cross-cultural comparison. *Empirical Text and Culture Research, 90–101*.
- Dhokalia, D., & Atreya, P. (2011). Designing skin response meter for psycho galvanic reflex. *AIP Conference Proceedings, 1414*.

- Dice, L. (1945). Measures of the amount of ecologic association between species. *Ecology*.
- Diduch, L., Muller, R., & Rigoll, G. (2007). A framework for modular signal processing systems with high-performance requirements. *Signal Processing*, 1159–1162. doi:10.1109/ICME.2007.4284861
- Dimberg, U. (1982). Facial reactions to facial expressions. *Psychophysiology*, 19(6), 643–647.
- Dimberg, U. (1998). Fear of snakes and facial reactions: A case of rapid emotional responding. *Scandinavian Journal of Psychology*.
- Dimberg, U., & Thunberg, M. (1998). Rapid facial reactions to emotional facial expressions. *Scandinavian Journal of Psychology*, 39(1), 39–45.
- Dimberg, U., Thunberg, M., & Elmehed, K. (2000). Unconscious facial reactions to emotional facial expressions. *Psychological Science*, 11(1), 86–89.
- Dittmar, A., & Lymberis, A. (2005). Smart clothes and associated wearable devices for biomedical ambulatory monitoring. *Solid-State Sensors, Actuators and Microsystems, 2005. Digest of Technical Papers. Transducers '05. The 13th International Conference on*, 1(1), 221–227. doi:10.1109/SENSOR.2005.1496398
- Doi, T. (1973). *The Anatomy of Dependence*. Tokyo: Kodansha International.
- Dollard, J. (1943). *Fear in battle*. New Haven, CT, US: Yale University Press.
- Domingues, D. (2011). Module for the acquisition and processing of biological signals related to the emotional state. *PAHCE - Pan American Health Care Exchanges*.
- Donaldson, J. (2010). Package R (t-sne). CRAN Repository.
- Donoho, D. (1995). De-noising by soft-thresholding. *Information Theory, IEEE Transactions on*.
- Dotsinsky, I. A., & Stoyanov, T. V. (2004). Ventricular Beat Detection in Single Channel Electrocardiograms. *BioMedical Engineering Online*, 9, 1–9.
- Douglas-Cowie, E., Cowie, R., & Sneddon, I. (2007). The humane database: Addressing the collection and annotation of naturalistic and induced emotional data. *Affective computing and .*
- Douglass, B. P. (1998). Safety-Critical Systems Design. *Electronic Engineering*, 70(862), 45–53.
- Dryer, D. (1998). Dominance and valence: a two-factor model for emotion in HCI. *Emotional and Intelligent: The Tangled Knot of Cognition*.

- Du, S., & Vuskovic, M. (2004). Temporal vs. Spectral Approach to Feature Extraction from Prehensile EMG Signals. *Information Reuse and Integration, 2004. IRI 2004. Proceedings of the 2004 IEEE International Conference on*, 344 – 350.
- Dubin, D. (2000). *Rapid Interpretation of EKG's*. Tampa: Cover Publishing Company.
- Duchenne, G.-B.-A. (de B. (1876). *Mécanisme de la physionomie humaine: où, Analyse électro-physiologique de l'expression des passions* (p. 263). Baillière: J.-B. Baillière.
- Duclos, S. E., Laird, J. D., Schneider, E., Sexter, M., Stern, L., & Van Lighten, O. (1989). Emotion-Specific Effects of Facial Expressions and Postures on Emotional Experience. *Journal of Personality and Social Psychology*, 57(1), 100–108.
- Durbin, J. (1973). The Fitting of Time Series Models. *Review of the International Statistical Institute*, 28(3), 344– 348,.
- Durso, F. T., Geldbach, K. M., & Corballis, P. (2012). Detecting Confusion Using Facial Electromyography. *Human Factors: The Journal of the Human Factors and Ergonomics Society*, 54(1), 60–69. doi:10.1177/0018720811428450
- Duskalov, I. K., Dotsinsky, I. A & Christov, I (1998). Developments in ECG acquisition, preprocessing, parameter measurement, and recording. *Engineering in Medicine and Biology Magazine, IEEE*, 17(2), 50–58. doi:10.1109/51.664031
- Dutton, D. G., & Aron, A. P. (1974). Some evidence for heightened sexual attraction under conditions of high anxiety. *Journal of Personality and Social Psychology*, 30(4), 510–517.
- Eckman, P., & Friesen, W. V. (1990). Voluntary Facial Action Generates Emotion-Specific Autonomic Nervous System Activity. *Psychophysiology*, 27(4), 22.
- Egbert, D. D., Kaburlasos, V. G., & Goodman, P. H. (1989). Invariant Feature Extraction for Neurocomputer Analysis of Biomedical Images. *Proceedings of the 2nd IEEE Symposium on Computer-based Medical Systems*, 69–73.
- Egloff, B., Tausch, A., Kohlmann, C.-W., & Krohne, H. (1995). Relationships between time of day, day of the week, and positive mood: Exploring the role of the mood measure. *Motivation and Emotion*, 19(2), 99 –110 . doi:10.1007/BF02250565
- Einthoven, W., Fahr, G., & De Waart, A. (1913). “Über die Richtung und die manifeste Grösse der Potentialschwankungen im menschlichen Herzen und” über den Einfluss der Herzlage auf die Form des Elektrokardiogramms. *Ugers Archiv European Journal of Physiology*, 150(6), 275–315.

- Ekkekakis, P. (2005). Variation and homogeneity in affective responses to physical activity of varying intensities: An alternative perspective on dose–response based on evolutionary. *Journal of Sports Sciences*.
- Ekman, P. (2003). Darwin, Deception, and Facial Expression. *Annals of the New York Academy of Sciences*, 1000, 205–221.
- Ekman, P. (1992a). Facial Expressions of Emotion: New Findings, New Questions. *Psychological Science*, 3(1), 34.
- Ekman, P. (1992b). Are There Basic Emotions?. *Psychological review*, 99(3), 550–553.
- Ekman, P. (1992c). An Argument for Basic Emotions. *Cognition & Emotion*, 6(3/4), 169–200.
- Ekman, P. (1994). All Emotions are Basic. In P Ekman & R. Davidson (Eds.), *The nature of emotion: Fundamental questions* (1st ed., pp. 15–19). New York: Oxford University Press.
- Ekman, P., Friesen, W. V., & Ancoli, S. (1980). Facial signs of emotional experience. *Journal of Personality and Social Psychology*, 39(6), 1125.
- Ekman, P., & Friesen, W. V. (1978). *Facial Action Coding System: A Technique for the Measurement of Facial Movement*. San Francisco: Consulting Psychologists Press.
- Ekman, P., & Rosenberg, E. L. (2005). *What the face reveals: Basic and applied studies of spontaneous expression using the Facial Action Coding System (FACS)*. (P. Ekman & E. L. Rosenberg, Eds.) (p. 672). New York: Oxford University Press, USA.
- Ekman, Paul. (1972). Universals and Cultural Differences in Facial Expressions of Emotion. *Nebraska Symposium on Motivation*, 19, 207–283.
- Ekman, Paul. (1999). Basic Emotions. In T. Dalgleish & M. Power (Eds.), *Handbook of Cognition and Emotion* (1st ed., pp. 45–60). Chichester: Wiley & Sons.
- Ekman, Paul. (2006). Commentaries: Duchenne and Facial Expression of Emotion. In -B (Ed.), *The Mechanism of Human Facial Expression* (pp. 270–284). Cambridge University Press.
- Ekman, Paul, Hager, J. C., & Friesen, W. V. (1981). The Symmetry of Emotional and Deliberate Facial Actions. *Psychophysiology*, 18(2), 101–106.
doi:10.1111/j.1469-8986.1981.tb02919.x
- Elena, M. M., Quero, J. M., & Borrego, I. (2006). An Optimal Technique for ECG Noise Reduction in Real Time Applications. *Computers in Cardiology*, 225–228.

- Elfering, A., & Simone, G. (2011). Ambulatory Assessment of Skin Conductivity During First Thesis Presentation: Lower Self-Confidence Predicts Prolonged Stress Response. *Applied Psychophysiology and Biofeedback*.
- Epp, C. (2010). *Identifying emotional states through keystroke dynamics*. University of Saskatchewan.
- Erasmus, M., Zijlstra, F. J., M., H. P., Hogescholen, F., Eindhoven, S. N., Centrum, D., Den Helder, K. M., et al. (2010). Detection of Dystrophy-Related Asymmetry in Skin Temperature using Video. Retrieved from <http://www.bigr.nl/website/static/research/videothermo.html>
- Esau, N., Wetzel, E., Kleinjohann, L., & Kleinjohann, B. (2007). Real-Time Facial Expression Recognition Using a Fuzzy Emotion Model. *Fuzzy Systems Conference, 2007. FUZZ-IEEE 2007. IEEE International* (pp. 1–6). IEEE. doi:10.1109/FUZZY.2007.4295451
- Esau, Natascha, Wetzel, E., Kleinjohann, L., & Kleinjohann, B. (2007). Real-Time Facial Expression Recognition Using Model. *Neural Networks*.
- Eyben, F., Wollmer, M., & Schuller, B. (2009). openEAR - Introducing the Munich Open-Source Emotion and Affect Recognition Toolkit. *Proceedings of the Affective Computing and Intelligent Interaction (ACII), IEEE*, 576–581.
- Facchinetti, L., Imbiriba, L., & Azevedo, T. (2006). Postural modulation induced by pictures depicting prosocial or dangerous contexts. *Neuroscience* .
- Fahimi, F., & Vaez Mousavi, M. (2011). Physiological Patterning of Short Badminton Serve: A Psychophysiological Perspective to Vigilance and Arousal. *World Applied Sciences Journal*, 12(3), 347–353.
- Faigin, G. (2008). *The Artist's Complete Guide to Facial Expression* (p. 288). New York: Watson-Guptill.
- Farthing, J. P., Borowsky, R., Chilibeck, P. D., Binsted, G., & Sarty, G. E. (2007). Neuro-physiological adaptations associated with cross-education of strength. *Brain topography*, 20(2), 77–88. doi:10.1007/s10548-007-0033-2
- Feldman, L. A. (1995). Attention to Valence and Arousal: Distinguishing Semantic and Affective Focus. *Journal of Personality and Social Psychology*, 69(1), 153–166.
- Fernandez, R., & Picard, R. W. (1998). Signal processing for recognition of human frustration. *Acoustics, Speech and Signal Processing, 1998. Proceedings of the 1998 IEEE International Conference on* (Vol. 6, pp. 3773–3776). IEEE.
- Fitzsimons, G. (2008). Automatic Effects of Brand Exposure on Motivated Behavior: How Apple Makes You. *Journal of Consumer Research*.
- Fodor, I. (2002). *A Survey of Dimension Reduction Techniques* (pp. 1–18).

- Fox, J. (2002). Nonparametric Regression. *An R and S-PLUS Companion to Applied Regression* (Vol. 2, pp. 1–15). Thousand Oaks, CA: Sage Publications.
- Frauke, F., & Christian, I. (2005). Evolutionary Tuning of Multiple SVM Parameters. *Neurocomputing*, *64*, 107–117.
- Fridlund, A. J. S. (1984). Pattern Recognition of Self-Reported Emotional State from Multiple-Site Facial EMG Activity During Affective Imagery. *Psychophysiology* *Nov84*, *21*(6), 17.
- Friesen, G. M., Jannett, T., CjAdallah, M. A., Yates, S. L., Quint, S. R., Nagle, H. T., & Auburn Univ., A. L. (1990). A Comparison of the Noise Sensitivity of Nine QRS Detection Algorithms. *IEEE Transactions. Biomedical Engineering*, *37*(1), 85–98.
- Fukuda, K. (2001). Eye blinks: new indices for the detection of deception. *International Journal of Psychophysiology*, *40*(3), 239–245.
- Fung, G. (2001). A Comprehensive Overview of Basic Clustering Algorithms. *IEEE*, *June*.
- Fung, J., & Mann, S. (2002). Exploring Humanistic Intelligence Through Physiologically Mediated Reality. *Proceedings of the 1st International Symposium on Mixed and Augmented Reality* (pp. 1–2).
- García, O., Favela, J., & Machorro, R. (1999). Emotional awareness in collaborative systems. *String Processing and Information Retrieval Symposium, 1999 and International Workshop on Groupware* (pp. 296–303). doi:10.1109/SPIRE.1999.796607
- García, O., Favela, J., & Machorro, R. (1999). Emotional Awareness in Collaborative Systems. *String Processing and Information Retrieval Symposium. IEEE*.
- Gelder, B. D. (2006). Towards the neurobiology of emotional body language. *Nature Reviews Neuroscience*.
- Gergen, K. J. (1985a). Social Constructionist Inquiry: Context and Implications. *The social construction of the person*, *3*, 18.
- Gergen, K. J. (1985b). The Social Constructionist Movement in Modern Psychology. *American psychologist*, *40*(3), 266–275.
- Gholam Hosseini, H., Reynolds, K. J., & Powers, D. (2001). A Multi-stage Neural Network Classifier for ECG Events. *2001 Conference Proceedings of the 23rd Annual International Conference of the IEEE Engineering in Medicine and Biology Society*, 1672–1675. doi:10.1109/IEMBS.2001.1020536
- Gilleade, K. M., & Dix, A. (2004). Using frustration in the design of adaptive videogames. *Proceedings of the 2004 ACM SIGCHI International Conference on Advances in computer entertainment technology* (pp. 228–232). ACM.

- Gini, C. (1912). Variabilità e mutabilità. *Reprinted in Memorie di metodologica statistica* (Ed. Pizetti E, Salvemini, T). Rome: Libreria Eredi Virgilio Veschi, 1.
- Globisch, J., Hamm, A. O., Esteves, F., & Ohman, A. (1999). Fear appears fast: temporal course of startle reflex potentiation in animal fearful subjects. *Psychophysiology*, 36(1), 66–75.
- Glover, J., & Gary, A. L. (1976). Procedures to increase some aspects of creativity. *Journal of Applied Behavior Analysis*.
- Goldberger, A. L., Amaral, L. A. N., Glass, L., Hausdorff, J. M., Ivanov, P. C., Mark, R. G., Mietus, J. E., et al. (2000). {PhysioBank, PhysioToolkit, and PhysioNet}: Components of a New Research Resource for Complex Physiologic Signals. *Circulation*, 101(23), e215–e220.
- Goldfinger, E. (1991). *Human Anatomy for Artists: The Elements of Form* (p. 368). New York: Oxford University Press, USA.
- Gotlib, I., Krasnoperova, E., Neubauer-Yue, D., & Joormann, J. (2004). Attentional Biases for Negative Interpersonal Stimuli in Clinical Depression. *Journal of Abnormal Psychology*, 113(1), 127–135.
- Gouizi, K., Bereksi Reguig, F., & Maaoui, C. (2011). Emotion recognition from physiological signals. *Journal of medical engineering & technology*, 35(6-7), 300–7. doi:10.3109/03091902.2011.601784
- Granholm, E., & Steinhauer, S. (2004). Pupillometric measures of cognitive and emotional processes. *International Journal of Psychophysiology*.
- Gray, J. A. (1985). The Neuropsychology of Anxiety. *Issues in Mental Health Nursing*, 7(1-4), 201–228.
- Grimm, M., & Kroschel, K. (2005). Evaluation of Natural Emotions using Self Assessment Manikins. *Automatic Speech Recognition and Understanding, 2005 IEEE Workshop on* (pp. 381–385). IEEE. doi:10.1109/ASRU.2005.1566530
- Grimm, M., Kroschel, K., & Narayanan, S. (2007). Support Vector Regression for Automatic Recognition of Spontaneous Emotions in Speech. *Acoustics, Speech and Signal Processing, 2007. ICASSP 2007. IEEE International Conference on* (Vol. 4, p. IV–1085–IV–1088). IEEE. doi:10.1109/ICASSP.2007.367262
- Groening, M., & Brooks, J. L. (2006). The Simpsons, Episode 8, Season 18, “The Haw-Hawed Couple.” Fox inc.
- Gross, J. J. (1998). The emerging field of emotion regulation: An integrative review. *Review of General Psychology*, 2(3), 271–299.
- Gross, J. J., & Levenson, R. W. (1995). Emotion Elicitation Using Films. *Cognition and Emotion*, 9(1), 87–108.

- Gross, J. J., Sutton, S. K., & Ketelaar, T. (1998). Relations between affect and personality: Support for the affect-level and affective-reactivity views. *Personality & Social Psychology Bulletin*, 24(3), 279–288.
- Grossman, P., & Wientjes, C. J. (2001). How breathing adjusts to mental and physical demands. *Respiration and emotion*, 43–55.
- Grudin, J. (1992). Utility and usability: research issues and development contexts. *Interacting with computers*, 4(2), 209–217.
- Guo, Y., & Gao, H. (2006). Emotion Recognition System in Images Based On Fuzzy Neural Network and HMM. *Cognitive Informatics, 2006. ICCI 2006. 5th IEEE International Conference on* (Vol. 1, pp. 73–78). IEEE.
doi:10.1109/COGINF.2006.365679
- Guyenet, P. (1990). Role of the ventral medulla oblongata in blood pressure regulation. In A. Loewy & K. M. Spyer (Eds.), *Central regulation of autonomic functions* (pp. 145–167). New York: Oxford University Press.
- Guyon, I., & Elisseeff, A. (2003). An introduction to variable and feature selection. *The Journal of Machine Learning Research*, 3, 1157–1182.
- Guyton, J. E. H. A. C. (2000). *Textbook of Medical Physiology 10th Edition*. Philadelphia: W. B. Saunders Company.
- Güler, I., & Übeyli, E. D. (2005). ECG beat classifier designed by combined neural network model. *Pattern Recognition*, 38(2), 199–208.
doi:10.1016/j.patcog.2004.06.009
- Haag, A., Goronzy, S., Schaich, P., & Williams, J. (2004). Emotion recognition using bio-sensors: First steps towards an automatic system. *Affective Dialogue Systems*, 36–48.
- Hagan, M., & Menhaj, M. (1994). Training Feedforward Networks with the Marquardt Algorithm. *IEEE Transactions on Neural Networks*, 5(6), 989–993.
- Haggard, E. A., & Isaacs, K. S. (1966). Micromomentary facial expressions as indicators of ego mechanisms in psychotherapy. *Methods of research in psychotherapy*. (pp. 154–165). New York: Appleton-Century-Crofts.
- Hama, H., & Tsuda, K. (1990). Finger-pressure waveforms measured on Clynès' Sentograph distinguish among emotions. *Perceptual and motor skills*, 70(2), 371.
- Hambley, A. R., Moruzzi, R. L., & Feldman, C. L. (1974). The use of intrinsic components in an ECG filter. *Biomedical Engineering, IEEE Transactions on*, (6), 469–473.
- Hamel, L. H. (2009). *Knowledge Discovery with Support Vector Machines (Wiley Series on Methods and Applications in Data Mining)* (p. 246). New Jersey: Wiley-Interscience.

- Hamilton, P. (2001). Open Source ECG Analysis Software. EP Limited.
- Hamilton, P. S. (2002). *Open Source ECG Analysis Software Documentation*. EP Limited.
- Hamilton, P. S., & Tompkins, W. J. (1986). Quantitative investigation of QRS detection rules using the MIT/BIH arrhythmia database. *IEEE Transactions on Biomedical Engineering*, 33(12), 1157–1165.
- Hamm, A., Greenwald, M. K., Bradley, M. M., & Lang, P. J. (1993). Emotional learning, hedonic change, and the startle probe. *Journal of Abnormal Psychology*, 102(3), 453–465.
- Hammond, H., & Fell, J. (1847). *A practical catechism*. (N. Pocock, Ed.) (16th ed., pp. §6–77). Oxford: John Henry Parker.
- Han, J., Bang, W., & Bien, Z. (2002). Feature set extraction algorithm based on soft computing techniques and its application to EMG pattern classification. *Fuzzy Optimization and Decision Making*, 1(3), 269–286.
- Han, S. H., Yun, M. H., Kwahk, J., & Hong, S. W. (2001). Usability of consumer electronic products. *International Journal of Industrial Ergonomics*, 28(3), 143–151.
- Hand, D. (1986). Recent advances in error rate estimation. *Pattern Recognition Letters*.
- Hannigan, J. A. (1995). *Environmental sociology: A social constructionist perspective* (1st ed., p. 248). Oxford: Routledge.
- Hargittai, S. (2005). Savitzky-Golay least-squares polynomial filters in ECG signal processing. *Computers in Cardiology*, 763–766.
- Harré, R. (1986). An outline of the social constructionist viewpoint. *The social construction of emotions*, 2–14.
- Hartigan, J. A., & Wong, M. A. (1979). A k-means clustering algorithm. *Journal of the Royal Statistical Society, Series C*, 28(1), 100–108.
- Haruki, Y., Homma, I., & Umezawa, A. (2001). *Respiration and emotion*. San Francisco: Springer Verlag.
- Hastie, T., Tibshirani, R., & Friedman, J. (2009). *The Elements of Statistical Learning* (2nd ed., p. 768). San Francisco: Springer.
- Havas, D., Glenberg, A., Gutowski, K., Lucarelli, M., & Davidson, R. (2009). Cosmetic Use of Botulinum Toxin-A Affects Processing of Emotional Language. *Nature Precedings*.

- Hayes, M. (1996). *Statistical Digital Signal Processing and Modeling*. Hayes, M.H. (p. 608). New York: John Wiley & Sons.
- Healey, J., & Picard, R. (2000). SmartCar: detecting driver stress. *Pattern Recognition*, 4, 218–221. doi:10.1109/ICPR.2000.902898
- Heinzel, G., Rudiger, A., & Schilling, R. (2002). *Spectrum and spectral density estimation by the Discrete Fourier transform (DFT), including a comprehensive list of window functions and some new flat-top windows* . (pp. 1–84).
- Hennenlotter, A., Dresel, C., Castrop, F., Ceballos-Baumann, A. O., Baumann, A. O. C., Wohlschläger, A. M., & Haslinger, B. (2009). The link between facial feedback and neural activity within central circuitries of emotion--new insights from botulinum toxin-induced denervation of frown muscles. *Cerebral Cortex*, 19(3), 537–42. doi:10.1093/cercor/bhn104
- Herbert, C., Kissler, J., Junghofer, M., Peyk, P., & Rockstroh, B. (2006). Processing of emotional adjectives: Evidence from startle EMG and ERPs. *Psychophysiology* Mar2006, 43(2), 11.
- Hess, E. H. (1972). Pupillometrics: A method of studying mental, emotional and sensory processes. *Handbook of psychophysiology*, 491–531.
- Hess, E. H., & Petrovich, S. B. (1987). Pupillary behavior in communication. *Nonverbal Behavior and Communication*. Erlbaum, Hillsdale, NJ, 327–348.
- Hess, U, Kappas, A., McHugo, G., & Kleck, R. (1989). An analysis of the encoding and decoding of spontaneous and posed smiles: The use of facial electromyography. *Journal of Nonverbal Behavior*, 13, 121–137.
- Hess, Ursula, Blairy, S., & Kleck, R. E. (1997). The intensity of emotional facial expressions and decoding accuracy. *Journal of Nonverbal Behavior*, 21(4), 241–257.
- Hess, Ursula, Philippot, P., & Blairy, P. (1998). Facial Reaction s to Em otion al Facial Exp ressions : Affect or Cogn ition ? *Emotion*, 12(4), 509–531.
- Hillman, C., Rosengren, K., & Smith, D. (2004). Emotion and motivated behavior: postural adjustments to affective picture viewing. *Biological Psychology*.
- Hochschild, A. (1979). Emotion work, feeling rules, and social structure. *American journal of Sociology*, 85(3), 551–575.
- Hong, J.-W., Han, M.-J., Song, K.-T., & Chang, F.-Y. (2007). A Fast Learning Algorithm for Robotic Emotion Recognition. *Computational Intelligence in Robotics and Automation, 2007. CIRA 2007. International Symposium on* (pp. 25–30). Jacksonville, FL, USA: IEEE. doi:10.1109/CIRA.2007.382865

- Hopfield, J. (1982). Neural networks and physical systems with emergent collective computational abilities. *Proceedings of the National Academy of Science*, 79(8), 2554–2558.
- Hristova, N., & O'hare, G. M. P. (2004). Ad-me: wireless advertising adapted to the user location, device and emotions. *System Sciences, 2004. Proceedings of the 37th Annual Hawaii International Conference on* (p. 0). IEEE. doi:10.1109/HICSS.2004.1265673
- Hristova, Nataliya, & Hare, G. M. P. O. (2004). Ad-me: Wireless Advertising Adapted to the User Location, Device and Emotions. *Science*, 00(C), 1–10.
- Hsu, C, Chang, C., & Lin, C. (2010). *A practical guide to support vector classification* (p. 16). Taiwan.
- Huang, H., Zhou, P., Li, G., & Kuiken, T. (2009). Spatial filtering improves EMG classification accuracy following targeted muscle reinnervation. *Annals of biomedical engineering*, 37(9), 1849–57. doi:10.1007/s10439-009-9737-7
- Huang, R., & Ma, C. (2006). Toward A Speaker-Independent Real-Time Affect Detection System. *Pattern Recognition, 2006. ICPR 2006. 18th International Conference on* (Vol. 1, pp. 1204–1207). IEEE. doi:10.1109/ICPR.2006.1127
- Hudgins, B., Parker, P., & Scott, R. (1993). A New Strategy for Multifunction Myoelectric Control. *Biomedical Engineering, IEEE Transactions on*, 40(1), 82 – 94.
- Hughes Medical Corp. (2010). InfraScan Digital Imaging System - Clinical Examples. Retrieved from <http://www.hughes-medical.com/products/infrascan-examples.htm>
- Hughes, N. P., & Tarassenko, L. (2003). Novel signal shape descriptors through wavelet transforms and dimensionality reduction. *Optical Science and Technology, SPIE's 48th Annual Meeting*.
- Hughes, N. P., Tarassenko, L., & Roberts, S. J. (2003). Markov Models for Automated ECG Interval Analysis. *Advances in Neural Information Processing Systems*, 16.
- Hyun, K. H., Kim, E. H., Kwak, Y. K., & Ho, E. (2007). Emotional Feature Extraction Based On Phoneme Information for Speech Emotion Recognition. *Science And Technology*, 802–806. doi:10.1109/ROMAN.2007.4415195
- Ikehara, C. S., & Crosby, M. E. (2005). Assessing cognitive load with physiological sensors. *Proceedings of the 38th Annual Hawaii International Conference on. IEEE* (Vol. 38). Published by the IEEE Computer Society.
- Iliopoulos, C. S., & Michalakopoulos, S. (2010). A Combinatorial Model for ECG Interpretation. *International Journal of Biological and Life Sciences*, 6(1), 10–14.

- Inverso, S. A. (2004). *Automatic Error Recovery Using P3 Response Verification for a Brain-Computer Interface*. Science.
- Irtel, H. (2007). PXLab: The Psychological Experiments Laboratory. Mannheim: University of Mannheim.
- Isbister, K., Höök, K., Sharp, M., & Laaksolahti, J. (2006). The sensual evaluation instrument: developing an affective evaluation tool. *Proceedings of the SIGCHI conference on Human Factors in computing systems*, 1163–1172.
- Izard, C. (1971). *The Face of Emotion* (p. 468). East Norwalk [CT, US]: Appleton-Century-Crofts.
- Jaccard, P. (1901). Etude comparative de la distribution florale dans une portion des Alpes et du Jura. *Bulletin de la Societaudoise des Sciences Naturelles*, 37, 547–579.
- Jain, A. K., Duin, R. P. W., Mao, J., & Member, S. (2000). Statistical Pattern Recognition: A Review. *IEEE Trans. Pattern Anal. Mach. Intell.*, 22(1), 4–37. doi:10.1109/34.824819
- James, W. (1884). What is an Emotion? *Mind*, 9(34), 188–205.
- Jancke, L. (1993). Different Facial And Introverts Emg-Reactions To Pictures Of Extraverts With Positive , Negative And Neutral Valence. *Person. indioid. Diff*, 14(I), 113–118.
- Janisse, M. (1974). Pupil size, affect and exposure frequency. *Social Behavior and personality*.
- Jané, R., Blasi, A., Garc'ia, J., & Laguna, P. (1997). Evaluation of an automatic threshold based detector of waveform limits in Holter ECG with the QT database. *Computers in Cardiology 1997* (pp. 295–298). IEEE.
- Jeleñ, P., & Zagrodzka, J. (2001). Heart rate changes in partially restrained rats during behaviorally and pharmacologically evoked emotional states. *Acta Neurobiologiae Experimentalis*, 61, 53–67.
- Jiang, D.-N., & Cai, L.-H. (2004). Speech emotion classification with the combination of statistic features and temporal features. *Multimedia and Expo, 2004. ICME '04. 2004 IEEE International Conference on* (pp. 1967–1970). Beijing.
- Joffe, E., & Lock, K. (2010). *Grounds for grounding: a circuit-to-system handbook* (1st ed., p. 1088). New jersey: Wiley & Sons.
- John, O. P., & Benet-Martínez, V. (2000). Measurement: Reliability, construct validation, and scale construction. Handbook of research methods in social and personality psychology. In R. W. Robins, R. C. Fraley, & R. F. Krueger (Eds.), *Handbook of research methods in social and personality psychology* (pp. 240–258). Cambridge University Press.

- Jordan, D., Stockmanns, G., Kochs, E. F., & Schneider, G. (2007). Median Frequency Revisited. *Anesthesiology*, *107*(3), 397–405.
- Jordan, J., & Whitlock, F. (1972). Emotions and the skin: The conditioning of scratch responses in cases of atopic dermatitis. *British Journal of Dermatology*, *86*(6), 574–585.
- Josephs, I. E. (1994). Display rule behavior and understanding in preschool children. *Journal of Nonverbal Behavior*, *18*(4), 301–326. doi:10.1007/BF02172291
- July, J., Kong, H., Xiang, H., Ren, F., Kuroiwa, S., & Jiang, P. (2005). An experimentation on creating a mental state transition network. *Information Acquisition, 2005 IEEE International Conference on* (pp. 432–436). IEEE. doi:10.1109/ICIA.2005.1635127
- Kagan, J., & Snidman, N. (1999). Early childhood predictors of adult anxiety disorders. *Biological Psychiatry*, *46*(11), 1536–1541.
- Kaiser, S., & Wehrle, T. (1996). Situated emotional problem solving in interactive computer games. *Proceedings of the VIXth Conference of the International Society for Research on Emotions, ISRE '96*, *96*, 276–280.
- Kaiser, S., Wehrle, T., & Edwards, P. (1994). Multi-modal emotion measurement in an interactive computer-game: A pilot-study. *Proceedings of the VIIIth Conference of the International Society for Research on Emotions*, 275–279.
- Kaiser, S., Wehrle, T., & Schmidt, S. (1998). Emotional Episodes, Facial Expressions, and Reported Feelings in Human-Computer Interactions. *Proceedings of the Xth Conference of the International Society for Research on Emotions* (pp. 82–86).
- Kaiser, Susanne, & Wehrle, T. (1992). Emotion research and AI: Some theoretical and technical issues. *Journal of Nonverbal Behaviour*, *16*(2), 65–140.
- Kanade, T., & Cohn, J. F. (2000). Comprehensive database for facial expression analysis. *Proceedings Fourth IEEE International Conference on Automatic Face and Gesture Recognition* (pp. 46–53). IEEE Comput. Soc. doi:10.1109/AFGR.2000.840611
- Kanade, Takeo, Cohn, J. F., & Tian, Y. (2000). Comprehensive Database for Facial Expression Analysis. *International conference on automatic face and gesture recognition* (pp. 1–8).
- Kania, M., Fereniec, M., & Maniewski, R. (2007). Wavelet Denoising for Multi-lead High Resolution ECG Signals. *Measurement Science Review*, *7*(4), 30–33.
- Katherine Isbister, N. S. (2008). *Game Usability: Advancing the Player Experience*. Boca Raton: CRC Press.
- Katsis, C. D. C. D., Katertsidis, N., Ganiatsas, G., Fotiadis, D. I. D. I., & Member, S. (2008). Toward Emotion Recognition in Car-Racing Drivers: A Biosignal

Processing Approach. *Systems, Man and Cybernetics, Part A, IEEE Transactions on*, 38(3), 502–512. doi:10.1109/TSMCA.2008.918624

- Keltner, D., & Ekman, P. (2004). Facial Expression of Emotion. In M. Lewis & J. Haviland-Jones (Eds.), *Handbook of Emotions* (2nd ed., pp. 236–249). New York: The Guilford Press.
- Kemper, T. (2000). Social models in the explanation of emotions. *Handbook of emotions.*, New York: The Guilford Press 14.
- Kemper, T. D. (1981). Social constructionist and positivist approaches to the sociology of emotions. *American Journal of Sociology*, 87(2), 336–362.
- Kemper, T. D. (1987). How many emotions are there? Wedding the social and the autonomic components. *American Journal of Sociology*, 93(2), 263–289.
- Kepecs, J. G., Milton, R., & Brunner, M. J. (1951). Relationship Between Certain Emotional States and Exudation into the Skin. *Psychosom Med*, 13(1), 10–17.
- Khalfa, S., Isabelle, P., Jean-Pierre, B., & Manon, R. (2002). Event-related skin conductance responses to musical emotions in humans. *Neuroscience letters*, 328(2), 145–149.
- Khan, I. A. (2007). Mood Independent Programming. *Research Quarterly*, (August), 28–31.
- Khan, I. A. (2008). Towards a mood sensitive integrated development environment to enhance the performance of programmers. *Analysis*, (December).
- Kim, E. H., Hyun, K. H., & Kwak, Y. K. (2005). Robust emotion recognition feature, frequency range of meaningful signal. *Robot and Human Interactive Communication, 2005. ROMAN 2005. IEEE International Workshop on* (pp. 667–671). IEEE. doi:10.1109/ROMAN.2005.1513856
- Kim, J., & Andre, E. (2008). Emotion recognition based on physiological changes in music listening. *Pattern Analysis and Machine Intelligence, IEEE Transactions on*, 30(12), 2067–2083.
- Kim, K., Bang, S., & Kim, S. (2004). Emotion recognition system using short-term monitoring of physiological signals. *Medical and biological engineering and computing*, 42(3), 419–427.
- Kim, K. H., Bang, S. W., & Kim, S. R. (2002). Development of person-independent emotion recognition system based on multiple physiological signals. *Engineering in Medicine and Biology* (Vol. 1, pp. 0–50). IEEE. doi:10.1109/IEMBS.2002.1134382
- Kim, N. Y., Shin, Y., & Kim, E. Y. (2007). Emotion-based Textile Indexing using Neural Networks. *Consumer Electronics, IEEE International Symposium on* (pp. 1–6). IEEE. doi:10.1109/ISCE.2007.4382230

- Kirsch, D. (1997). *The sentic mouse: Developing a tool for measuring emotional valence*. Massachusetts Institute of Technology.
- Kleinginna, P. R., & Kleinginna, A. M. (1981). A categorized list of emotion definitions, with suggestions for a consensual definition. *Motivation and Emotion*, 5(4), 345–379. doi:10.1007/BF00992553
- Kleinsmith, A., De Silva, P. R., & Bianchi-Berthouze, N. (2006). Cross-cultural differences in recognizing affect from body posture. *Interacting with Computers*, 18(6), 1371–1389.
- Ko, E.-J., Lee, H.-J., & Lee, J.-W. (2005). An Intelligent Context-Aware Service Engine Based on Ontology. *Computational Intelligence for Modelling, Control and Automation, 2005 and International Conference on Intelligent Agents, Web Technologies and Internet Commerce, International Conference on* (Vol. 1, pp. 485–491). IEEE. doi:10.1109/CIMCA.2005.1631311
- Koelstra, S., Member, S., Lee, J., Yazdani, A., Ebrahimi, T., Pun, T., Nijholt, A., et al. (2011). DEAP : A Database for Emotion Analysis using Physiological Signals. *EEE TRANS. AFFECTIVE COMPUTING*, 1–15.
- Kohavi, R. (1995). A Study of Cross-Validation and Bootstrap for Accuracy Estimation and Model Selection. *International Joint Conference on Artificial Intelligence*, 14(2), 1137–1143.
- Kohler, B. U., Hennig, C., & Orglmeister, R. (2002). The Principles of Software QRS Detection. *Engineering in Medicine and Biology Magazine, IEEE*, 21(1), 42–57.
- Kohn, A., & Kalat, J. (2000). Preparing for an important event: Demonstrating the modern view of classical conditioning. In M. E. Ware & D. E. Johnson (Eds.), *Handbook of Demonstrations and Activities in the Teaching of Psychology* (2nd ed., pp. 128–130). New-Jersey: Psychology Pres.
- Kokubo, H., Taniguchi, J., Yamamoto, M., & Hirasawa, M. (1998). Categorization with Temperature Distribution of the Human Hand Surface. *Journal of International Society of Life Information Science*, 16, 247–254.
- Koot, P., & Deurenberg, P. (1995). Comparison of changes in energy expenditure and body temperatures after caffeine consumption. *Annals of Nutrition and Metabolism*, 39(3), 135–142.
- Korürek, M., & Nizam, A. (2008). A new arrhythmia clustering technique based on Ant Colony Optimization. *Journal of Biomedical Informatics*, 41(6), 874–881.
- Kostoulas, T., Ganchev, T., Mporas, I., & Fakotakis, N. (2007). Detection of Negative Emotional States in Real-World Scenario. *19th IEEE International Conference on Tools with Artificial Intelligence (ICTAI 2007)* (Vol. 2, pp. 502–509). IEEE. doi:10.1109/ICTAI.2007.86

- Krause, E. (1987). *Taxicab geometry: An adventure in non-Euclidean geometry*. London: . Dover Publications.
- Krauss, R. M., & Putnam, L. E. (1985). Dimensions of emotion in facial and autonomic responses. *Meetings of American Association for the Advancement of Science*. Washington, D.C.
- Krohne, H. (2009). Individual differences in emotional reactions and coping. In R. Davidson, K. Scherer, & H. Goldsmith (Eds.), *Handbook of Affective Sciences* (1st ed., pp. 698–725). New York: Oxford University Press.
- Kryzstoforski, K., Wolczowski, A., & Helt, K. (2004). Recognition of Palm Finger Movements on the Basis of EMG Signals with the Application of Wavelets. *TASK Quarterly*, 8(2), 269–280.
- Kudielka, B. M., Schommer, N. C., Hellhammer, D. H., & Kirschbaum, C. (2004). Acute HPA axis responses, heart rate, and mood changes to psychosocial stress (TSST) in humans at different times of day. *Psychoneuroendocrinology*, 29(8), 9. doi:doi:10.1016/j.psyneuen.2003.08.009
- Kuli, D. (2007). Affective State Estimation for Human–Robot Interaction. *IEEE Transactions on Robotics*, 23(5), 991–1000.
- Kulic, D., & Croft, E. (2005). Anxiety detection during human-robot interaction. *Intelligent Robots and Systems, 2005. (IROS 2005). 2005 IEEE/RSJ International Conference on* (pp. 616–621). doi:10.1109/IROS.2005.1545012
- Kulic, D., & Croft, E. A. (2007a). Affective State Estimation for Human–Robot Interaction. *Robotics, IEEE Transactions on [see also Robotics and Automation, IEEE Transactions on]*, 23(5), 991–1000. doi:10.1109/TRO.2007.904899
- Kulic, D., & Croft, E. A. (2007b). Affective State Estimation for Human–Robot Interaction. *Robotics, IEEE Transactions on [see also Robotics and Automation, IEEE Transactions on]*, 23(5), 991–1000. doi:10.1109/TRO.2007.904899
- Kulic, D., & Croft, E. A. (2007c). Affective State Estimation for Human–Robot Interaction. *Robotics, IEEE Transactions on [see also Robotics and Automation, IEEE Transactions on]*, 23(5), 991–1000.
- Kulic, D., Croft, E. E. A. A., & Kulić, D. (2006). Estimating Robot Induced Affective State using Hidden Markov Models. *Robotics, IEEE Transactions on [see also Robotics and Automation, IEEE Transactions on]*, 23(5), 257–262. doi:10.1109/TRO.2007.904899
- Kulić, D., & Croft, E. (2005). Anxiety Detection during Human-Robot Interaction. *Intelligent Robots and Systems 2005* (pp. 616– 621).

- Kullback, S., & Leibler, R. A. (1951). On information and sufficiency. *The Annals of Mathematical Statistics*, 22(1), 79–86.
- Kuniecki, M., Urbanik, A., Sobiecka, B., Kozub, J., & Binder, M. (2003). Central control of heart rate changes during visual affective processing as revealed by fMRI. *Acta Neurobiologiae Experimentalis*, 63, 39–48.
- Kunzmann, U., G, V., J, S., & Bolz, A. (2002). Parameter extraction of ecg signals in real-time. *Biomedical Engineering*, 47(1b), 2–5.
- Kuroda, K., Izumikawa, I., & Kouketsu, O. (2009). Logical Mediation Structures for Toyota's Driver Support Systems. *EPS*.
- Kut, E., Candia, V., Von Overbeck, J., Pok, J., Fink, D., & Folkers, G. (2011). Pleasure-Related Analgesia Activates Opioid-Insensitive Circuits. *The Journal of Neuroscience*, 31(11), 4148–53.
- Kwon, D.-S., Kwak, Y. K., Park, J. C., Chung, M. J., Jee, E.-S., Park, K.-S., Kim, H.-R., et al. (2007). Emotion Interaction System for a Service Robot. *Robot and Human interactive Communication, 2007. RO-MAN 2007. The 16th IEEE International Symposium on* (pp. 351–356). IEEE.
- Labouvie-Vief, G., Lumley, M. A., Jain, E., & Heinze, H. (2003). Age and gender differences in cardiac reactivity and subjective emotion responses to emotional autobiographical memories. *Emotion*, 3(2), 115–126. doi:10.1037/1528-3542.3.2.115
- Lacey, B., & Lacey, J. (1974). Studies of heart rate and other bodily processes in sensorimotor behavior. *Cardiovascular psychophysiology: Current issues in response mechanisms, biofeedback, and methodology* (pp. 538–564). AldineTransaction.
- Lance, G. N., & Williams, W. T. (1966). Computer programs for hierarchical polythetic classification ("similarity analysis"). *Computer Journal*, 9(1), 60 – 64. doi:10.1093/comjnl/9.1.60
- Lane, R. D., & Nadel, L. (2000). *Cognitive Neuroscience of Emotion*. (Richard D. Lane & L. Nadel, Eds.). New York: Oxford University Press, USA.
- Lane, R. D., Waldstein, S. R., Chesney, M. A., Jennings, J. R., Lovallo, W. R., Kozel, P. J., Rose, R. M., et al. (2009). The rebirth of neuroscience in psychosomatic medicine, Part I: historical context, methods, and relevant basic science. *Psychosomatic* .
- Lang, P J, Bradley, M. M., & Cuthbert, B. N. (1997). *International affective picture system (IAPS): instruction manual and affective ratings*. Birmingham: NIMH Center for the Study of Emotion and Attention.
- Lang, P., Bradley, M., & Cuthbert, N. (2001). *International affective picture system (IAPS): instruction manual and affective ratings*. Florida.

- Lang, P.J., Kozak, M. J., Miller, G. A., Levin, D. N., & McLean Jr, A. (1980). Emotional imagery: Conceptual structure and pattern of somato-visceral response. *Psychophysiology*, *17*(2), 179–192.
- Lang, Peter J, Bradley, M. M., & Cuthbert, B. N. (1998). Emotion, Motivation, and Anxiety: Brain Mechanisms and Psychophysiology. *Biological Psychiatry*, *44*(12), 1248–1263.
- Larsen, J. T., Norris, C. J., & Cacioppo, J. T. (2003). Effects of positive and negative affect on electromyographic activity over zygomaticus major and corrugator supercilii. *Psychophysiology*, *40*, 776–785.
- Larsen, P., & Ketelaar, T. (1991). Personality and susceptibility to positive and negative emotional states. *Journal of Personality and Social Psychology*, *61*(1), 132–140.
- Lasaitis, C., Ribeiro, R. L., & Bueno, O. F. . (2008). Brazilian norms for the International Affective Picture System (IAPS) – comparison of the affective ratings for new stimuli between Brazilian and North-American subjects. *Jornal Brasileiro de Psiquiatria*, *57*(4).
- Lawlor, L. (1980). Overlap, similarity, and competition coefficients. *Ecology*, *61*, 245–251.
- Lawton, M. P., Kleban, M. H., Rajagopal, D., & Dean, J. (1992). Dimensions of affective experience in three age groups. *Psychology and Aging*, *7*(2), 171–184.
- Leary, M. R. (2009). The self and emotion: the role of self-reflection in the generation and regulation of affective experience. In R. Davidson, K. Scherer, & H. Goldsmith (Eds.), *Handbook of Affective Sciences* (1st ed., pp. 773–786). New York: Oxford University Press.
- Lecture, W. M., Luca, C. J. D., & Center, N. R. (1997). T u s e b. *Journal of Applied Biomechanics*, (July 1993), 1–38.
- Lee, C. K., Yoo, S. K., Park, Y., Kim, N., Jeong, K., & Lee, B. (2005). Using Neural Network to Recognize Human Emotions from Heart Rate Variability and Skin Resistance. *Engineering in Medicine and Biology Society, 2005. IEEE-EMBS 2005. 27th Annual International Conference of the* (pp. 5523–5525). doi:10.1109/IEMBS.2005.1615734
- Lee, C., & Lee, G. (2007a). Emotion Recognition for Affective User Interfaces using Natural Lan- guage Dialogs. *Science And Technology*, 798–801.
- Lee, C., & Lee, G. (2007b). Emotion Recognition for Affective User Interfaces using Natural Language Dialogs. *Robot and Human interactive Communication, 2007. RO-MAN 2007. The 16th IEEE International Symposium on* (pp. 798–801). IEEE. doi:10.1109/ROMAN.2007.4415194

- Lee, D., Kwak, S., & Kim, M. (2007). Application of Biological Signal to the Expressions of Robotic Emotions. *Robot and Human interactive Communication, 2007. RO-MAN 2007. The 16th IEEE International Symposium on* (pp. 1119–1124). IEEE. doi:10.1109/ROMAN.2007.4415248
- Lee, S, Kim, J., & Park, S. (1996). An enhanced feature extraction algorithm for EMG pattern classification. *IEEE Transactions on Rehabilitation Engineering*, 4(4), 439–443.
- Lee, Seungwhan, & Lee, S.-Y. (2002). Emotional Responses to Web-based Interactive Storytelling. *Journal of Personality*.
- Leidelmeijer, K. (1991). *Emotions: An Experimental Approach*. Tilburg: Tilburg University Press.
- Leng, H., Lin, Y., & Zanzi, L. (2007). An experimental study on physiological parameters toward driver emotion recognition. *Lecture Notes in Computer Science : Ergonomics and Health Aspects of Work with Computers*, 4566/2007, 237–246.
- Leon, E, Clarke, G., Callaghan, V., & Sepulveda, F. (2007). A user-independent real-time emotion recognition system for software agents in domestic environments. *Engineering applications of Artificial Intelligence*, 30(3), 337–345.
- Leon, E, Clarke, G., Sepulveda, F., & Callaghan, V. (2004). Neural Network-Based Improvement in Class Separation of Physiological Signals for Emotion Classification. *Heart*.
- Leon, E, Clarke, G., Sepulveda, F., & Callaghan, V. (2005). Real-time Physiological Emotion Detection Mechanisms: Effects of Exercise and Affect Intensity. *Conference proceedings : ... Annual International Conference of the IEEE Engineering in Medicine and Biology Society. IEEE Engineering in Medicine and Biology Society. Conference*, 5, 4719–22. doi:10.1109/IEMBS.2005.1615525
- Leon, E., Clarke, G., Sepulveda, F., & Callaghan, V. (2004). Optimised attribute selection for emotion classification using physiological signals. *Engineering in Medicine and Biology Society*, 26, 184–187. doi:10.1109/IEMBS.2004.1403122
- Leon, Enrique, Clarke, G., Callaghan, V., & Sepulveda, F. (2004). Real-time detection of emotional changes for inhabited environments. *Computers & Graphics*, 28(4), 635–642.
- Lehtola, L., Karsikas, M., Koskinen, M., Huikuri, H., & Seppänen, T. (2008). Effects of noise and filtering on SVD-based morphological parameters of the T wave in the ECG. *Journal of Medical Engineering & Technology*, 32(5), 400–407.
- Levenson, R. W., Carstensen, L. L., Friesen, W. V., & Ekman, P. (1991). Emotion, physiology, and expression in old age. *Psychology and Aging*, 6(1), 28–35.

- Levinson, N. (1946). The Wiener RMS (root mean square) Error Criterion in Filter Design and Prediction. *Journal of Mathematics and Physics*, 25, 261–278.
- Levkov, C., Mihov, G., Ivanov, R., Daskalov, I., Christov, I., & Dotsinsky, I. (2005a). BioMedical Engineering OnLine. *BioMedical Engineering Online*, 18, 1–18.
- Levkov, C., Mihov, G., Ivanov, R., Daskalov, I., Christov, I., & Dotsinsky, I. (2005b). Removal of power-line interference from the ECG: a review of the subtraction procedure. *Biomed Eng Online*, 2005(4), 1–18.
- Lewis, C., Hair, D. C., & Schoenberg, V. (1989). Generalization, consistency, and control. *ACM SIGCHI Bulletin*, 20(SI), 1–5.
- Lewis, P. A., Critchley, H. D., Rotshtein, P., & Dolan, R. J. (2007). Neural correlates of processing valence and arousal in affective words. *Cerebral Cortex*, 17(3), 742–748.
- Li, W., Zhang, Y., & Fu, Y. (2007). Speech Emotion Recognition in E-learning System Based on Affective Computing. *Natural Computation, 2007. ICNC 2007. Third International Conference on* (Vol. 5, pp. 809–813). IEEE. doi:10.1109/ICNC.2007.677
- Libby Jr, W. L., Lacey, B. C., & Lacey, J. I. (1973). Pupillary and cardiac activity during visual attention. *Psychophysiology*, 10(3), 270–294.
- Lin, H.-T., & Lin, C.-J. (2003). A study on sigmoid kernels for SVM and the training of non-PSD kernels by SMO-type methods. *submitted to Neural Computation*.
- Lin, I.-M., & Peper, E. (2009). Psychophysiological patterns during cell phone text messaging: A preliminary study. *Applied psychophysiology and Biofeedback*, 34(1), 53–57.
- Lippmann, R. P. (1989). Pattern classification using neural networks. *Communications Magazine, IEEE*, 27(11), 47–50, 59–64.
- Lisetti, C L, & Nasoz, F. (2004). Using noninvasive wearable computers to recognize human emotions from physiological signals. *EURASIP Journal on Applied Signal Processing, 2004*, 1672–1687.
- Lisetti, C, & Nasoz, F. (2005). Affective intelligent car interfaces with emotion recognition. *Proceedings of 11th International Conference on* .
- Lisetti, Christine L, & Nasoz, F. (2002). MAUI: a Multimodal Affective User Interface. *Proceedings of the tenth ACM international conference on Multimedia* (pp. 161–170).
- Lisetti, Christine, & Nasoz, F. (2006). Categorizing Autonomic Nervous System (ANS) Emotional Signals using Bio-Sensors for HRI within the MAUI Paradigm. *Robot and Human Interactive Communication, The 15th IEEE*

International Symposium on (pp. 277–284). IEEE.
doi:10.1109/ROMAN.2006.314430

Little, M. a., & Jones, N. S. (2010). Sparse Bayesian step-filtering for high-throughput analysis of molecular machine dynamics. *2010 IEEE International Conference on Acoustics, Speech and Signal Processing*, 4162–4165.
doi:10.1109/ICASSP.2010.5495722

Liu, A. (2004). *The effect of oversampling and undersampling on classifying imbalanced text datasets*. Texas at Austin.

Liu, C., & Conn, K. (2008). Physiology-based affect recognition for computer-assisted intervention of children with Autism Spectrum Disorder. *International Journal of Human-* .

Liu, T., Zhu, B., Sun, S., & Yang, C. (2006). Music's Affective Computing Model Based on Fuzzy Logic. *Intelligent Control and Automation, 2006. WCICA 2006. The Sixth World Congress on* (Vol. 2, pp. 9477–9481). IEEE.
doi:10.1109/WCICA.2006.1713837

Loewenfeld, I. E. (1966). Pupil size. *Survey of Ophthalmology*, 11, 291–294.

Lottridge, D., Chignell, M., & Jovicic, A. (2011). Affective Interaction: Understanding, Evaluating, and Designing for Human Emotion. *Reviews of Human Factors and Ergonomics*, 7(1), 197–217.
doi:10.1177/1557234X11410385

Lowen, A. (1978). *The language of the body*. New York: Collier.

Lowenstein, O., Feinberg, R., & Loewenfeld, I. (1963). Pupillary Movements During Acute and Chronic Fatigue A New Test for the Objective Evaluation of Tiredness. *Investigative Ophthalmology*

Luca, C. J. D. (2002). *Surface Electromyography: Detection And Recording* (pp. 1–10).

Luca, G. D. (2003). Fundamental Concepts in EMG Signal Acquisition. *Distribution*, (March).

Lynn, P. A. (1977). Online digital filters for biological signals: some fast designs for a small computer. *Medical & Biological Engineering & Computing*, 15(5), 534–540. doi:10.1007/BF02442281

MATLAB. (2003). Natick, Massachusetts: The MathWorks Inc.

MacLean, P. (1952). Some psychiatric implications of physiological studies on frontotemporal portion of limbic system (visceral brain). *Electroencephalography & Clinical Neurophysiology*, 4, 407–18.

- Mahmoodabadi, S. Z., Ahmadian, A., & Abolhasani, M. D. (2005). Ecg feature extraction using daubechies wavelets. *Visualization, Imaging, and Image Processing, Conference on*, 343–348.
- Maier, C., Dickhaus, H., Bauch, M., & Penzel, T. (2003). Comparison of heart rhythm and morphological ECG features in recognition of sleep apnea from the ECG. *Computers in Cardiology, 2003* (pp. 311–314). IEEE.
- Malatesta, C. Z., & Haviland, J. M. (1982). Learning display rules: The socialization of emotion expression in infancy. *Child Development*, 53, 991–1003.
- Mandryk, R. (2005). *Modeling user emotion in interactive play environments: A fuzzy physiological approach*. Simon Fraser University.
- Mandryk, R.L., & Inkpen, K. M. (2004). Physiological indicators for the evaluation of co-located collaborative play. *Proceedings of the 2004 ACM conference on Computer supported cooperative work* (pp. 102–111). ACM.
- Mandryk, R.L., Inkpen, K. M., & Calvert, T. W. (2006). Using psychophysiological techniques to measure user experience with entertainment technologies. *Behaviour & Information Technology*, 25(2), 141–158.
- Mandryk, Regan L., & Atkins, M. S. (2007). A fuzzy physiological approach for continuously modeling emotion during interaction with play technologies. *International Journal of Human-Computer Studies*, 66(4), 329–347.
- Mantysaari, M. J., Antila, K. J., & Peltonen, T. E. (1988). Circulatory effects of anticipation in a light isometric handgrip test. *Psychophysiology*, 25(2), 179–184.
- Mar, R. A., Oatley, K., Djikic, M., & Mullin, J. (2010). Emotion and narrative fiction: Interactive influences before, during, and after reading. *Cognition & Emotion*, 1–16.
- Markatou, M., & Tian, H. (2006). Analysis of variance of cross-validation estimators of the generalization error. *Journal of Machine Learning Research*, 6, 1127–1168.
- Martin, L. A., Doster, J. A., Critelli, J. W., Lamberta, P. L., Purduma, M., Powersa, C., & Prazaka, M. (2010). Ethnicity and Type D personality as predictors of heart rate variability. *International Journal of Psychophysiology*, 76(2), 118–121.
- Massavelli, B. (2010, September 1). *An Investigation into the Emotional Reactivity of Australian Older Adults: Are there age-related differences in the processing of affective stimuli?* University of Queensland.
- Matsumoto, D. (1987). The role of facial response in the experience of emotion: More methodological problems and a meta-analysis. *Journal of Personality and Social Psychology*, 52(4), 769–774.

- Matsumoto, D. R. (1996). *Unmasking Japan: myths and realities about the emotions of the Japanese* (p. 179). Stanford, CA: Stanford University Press.
- Maulik, U., & Bandyopadhyay, S. (2002). Performance evaluation of some clustering algorithms and validity indices. *IEEE Transactions on Pattern Analysis and Machine Intelligence*, 24(12), 1650–1654. doi:10.1109/TPAMI.2002.1114856
- McAdams, D. (1999). Functional interdependence and product similarity based on customer needs. *Research in Engineering Design*.
- McCraty, R., Atkinson, M., & Bradley, R. (2004). Electrophysiological evidence of intuition: Part 1. The surprising role of the heart. *The Journal of Alternative & Complementary Medicine*, 10(1), 133–143.
- McEwen, B. S., & Seeman, T. (2009). Stress and affect: Applicability of the concepts of allostasis and allostatic load. In R. Davidson, K. Scherer, & H. Goldsmith (Eds.), *Handbook of Affective Sciences* (1st ed., pp. 1117–1138). New York: Oxford University Press.
- McIntosh, D. N. (1996). Facial feedback hypotheses: Evidence, implications, and directions. *Motivation and Emotion*, 20(2), 121–147.
- McManis, M., Bradley, M., Berg, W. K., Cuthbert, B. N., & Lang, P. J. (2001). Emotional reactions in children: Verbal, physiological, and behavioral responses to affective pictures. *Psychophysiology*, 38(2), 222–231.
- Mcdarby, P., Chazal, R., Reilly, G., & Celler, B. (2000). Classification of the electrocardiogram using selected wavelet coefficients and linear discriminants. *Signal Processing*, (June).
- Meier, S. (1985). Computer aversion. *Computers in Human Behavior*.
- Mendoza, R., Rubens, N., & Okamoto, T. (2010). Hierarchical Aggregation Prediction Method. *JMLR: Workshop and Conference Proceedings* (Vol. 11).
- Merletti, A. R., & Torino, P. (1999). Standards for Reporting EMG Data. *Journal of Electromyography and Kinesiology (JEK)*.
- Mesquita, B. (2009). Emotions as dynamic cultural phenomena. In R. Davidson, K. Scherer, & H. Goldsmith (Eds.), *Handbook of Affective Sciences* (1st ed., pp. 871–890). New York: Oxford University Press.
- Michael, E., Dawson, A., Schell, M., & Filion, D. (1990). The electrodermal system. In Cacioppo & Tassinari (Eds.), *Principles of Psychophysiology: Physical, social and inferential elements* (1st ed., pp. 295–324). Cambridge: Cambridge University Press.
- Mierswa, I., & Wurst, M. (2006). Yale: Rapid prototyping for complex data mining tasks. *12th ACM SIGKDD international conference on Knowledge discovery and data mining*.

- Mihov, S. G., Ivanov, R. M., & Popov, A. N. (2008). Real-Time Subtraction Procedure for Eliminating Power-line Interference from ECG. *Proceedings of Electronics 2008 (ET2008)* (pp. 55–60).
- Mikels, J., Fredrickson, B., Larkin, G., Lindberg, C., Maglio, S., & Reuter-Lorenz, P. (2005). Emotional category data on images from the International Affective Picture System. *Behavior research methods*, 37(4), 626–30.
- Mineka, S., Davidson, M., Cook, M., & Keir, R. (1984). Observational conditioning of snake fear in rhesus monkeys. *Journal of Abnormal Psychology*, 93(4), 355.
- Minsky, M. L., & Papert, S. (1969). *Perceptrons: an introduction to computational geometry* (1st ed., p. 292). Cambridge, MA: The MIT Press.
- Mittelmann, B., & Wolff, H. G. (1939). Affective states and skin temperature: Experimental study of subjects with “cold hands” and Raynaud’s syndrome. *Psychosomatic Medicine*, 1(2), 271.
- Mittelmann, Bela, Wolff, H. G., & Harold, G. (1943). Emotions and skin temperature: Observations on patients during psychotherapeutic (psychoanalytic) interviews. *Psychosomatic Medicine*, 5(3), 211.
- Mohammad, Y., & Nishida, T. (2010). Using physiological signals to detect natural interactive behavior. *Applied Intelligence*, 33(1), 79–92. doi:10.1007/s10489-010-0241-4
- Moltó, J., Montañés, S., & Poy, R. (1999). Un método para el estudio experimental de las emociones: el International Affective Picture System (IAPS). Adaptación española. *Revista de psicología general y aplicada: Revista de la Federación Española de Asociaciones de Psicología*, 52(1), 55–87.
- Money, Arthur, G., & Agius, H. (2008). Feasibility of personalized affective video summaries. *Lecture Notes in Computer Science : Affect and Emotion in Human-Computer Interaction*, 4868/2008, 194–208.
- Monk, T. H., Buysse, D. J., Reynolds, C. F., Berga, S. L., Jarrett, D. B., Begley, A. E., & Kupfer, D. J. (1997). Circadian rhythms in human performance and mood under constant conditions. *Journal of Sleep Research*, 6, 9–18.
- Morris, J. D., & Burke, C. M. (1995). SAM: The Self-Assessment Manikin An Efficient Cross-Cultural Measurement Of Emotional Response 1. *Journal of Advertising Research*, (December).
- Mower, E., Lee, S., Mataric, M. J., Narayanan, S., & Sungbok Lee. (2008). Human perception of synthetic character emotions in the presence of conflicting and congruent vocal and facial expressions. *Acoustics, Speech and Signal Processing*, 2201–2204. doi:10.1109/ICASSP.2008.4518081

- Mulder, G., Mulder, L. J. M., & Veldeman, J. B. P. (1985). Mental tasks as stressors. In A. Steptoe, H. Riiddel, & H. Neus (Eds.), *Clinical and methodological issues in cardiovascular psychophysiology* (pp. 30–44). Berlin: Springer.
- Muller, L., Turner, G., Khut, G., & Edmonds, E. (2006). Creating Affective Visualisations for a Physiologically Interactive Artwork. *Information Visualization, 2006. IV 2006. Tenth International Conference on* (pp. 651–657). doi:10.1109/IV.2006.36
- Muller, Lizzie, Turner, G., Khut, G., & Edmonds, E. (2006). Creating Affective Visualisations for a Physiologically Interactive Artwork. *Information Visualization*, 0–6.
- Mundy-Castle, A., & McKiever, B. (1953). The psychophysiological significance of the galvanic skin response. *Psychology*, 46(1).
- Myers, C., & Rabiner, L. (1981). A Comparative Study of Several Dynamic Time-Warping Algorithms for Connected-Word. *Bell System Technical Journal*, 60(7), 1389–1409.
- Nakasone, A., Prendinger, H., & Ishizuka, M. (2005). Emotion recognition from electromyography and skin conductance. *The Fifth International Workshop on Biosignal Interpretation (BSI-05)* (pp. 219–222). Tokyo: Citeseer.
- Nasoz, F., Alvarez, K., Lisetti, C., & Finkelstien, N. (2003). Emotion recognition from physiological signals for presence technologies. *International Journal of* .
- Nass, C, Jonsson, I., & Harris, H. (2005). Improving automotive safety by pairing driver emotion and car voice emotion. *CHI'05 extended abstracts on Human factors in computing systems*, 1973–1976.
- Nass, Clifford, Steuer, J., & Tauber, E. R. (1994). Computers are Social Actors. *Proceedings of the SIGCHI conference on Human factors in computing systems: celebrating interdependence* (pp. 72–78).
- Natarajan, K., Acharaya, R., Alia, F., Tiboleng, T., & Puthusserypady, S. K. (2004). Nonlinear Analysis of EEG Signals at Different Mental States. *BioMedical Engineering Online*, 3(7), 1–11.
- Nathan, N. (2003). Influence of propofol concentrations on multipulse transcranial motor evoked potentials. *British Journal of Anaesthesia*, 91(4), 493–497. doi:10.1093/bja/aeg211
- Nazzal, A. A., & Churarat, A. (2000). A New daylight glare evaluation method. *Journal of Light & Visual Environment* , 24(2), 219–227.
- Neerinx, M. A., & Streefkerk, J. W. (2003). Interacting in Desktop and Mobile Context: Emotion, Trust and Task Performance. *Human Factors*, 119–132.

- Nicol, A. A. (1999). *Presenting Your Findings: A Practical Guide for Creating Tables*. (31st ed.). Washington, DC:: American Physiological Association.
- Nightingale, D. J., & Cromby, J. (1999). *Social constructionist psychology: A critical analysis of theory and practice*. Philadelphia: Open Univ Press.
- Oatley, K. (1999). Why Fiction May Be Twice as True as Fact: Fiction as Cognitive and Emotional Simulation. *Review of General Psychology*, 3(2), 101–117.
- Oberman, L. M., Winkielman, P., & Ramachandran, V. S. (2007). Face to face: blocking facial mimicry can selectively impair recognition of emotional expressions. *Social neuroscience*, 2(3-4), 167–78.
doi:10.1080/17470910701391943
- Ohman, A. (2009). Of snakes and faces: an evolutionary perspective on the psychology of fear. *Scandinavian journal of psychology*, 50(6), 543–52.
doi:10.1111/j.1467-9450.2009.00784.x
- Oliveira, A. M., Fonseca, I. B., Teixeira, M., & Simões, F. (2005). A functional measurement approach to the “self-assessment manikin.” *Proceedings of the Twenty First Annual Meeting of the International Society for Psychophysics*, 251–256.
- Oliveira, A., Teixeira, M., Fonseca, I. . B., Oliveira, M., Kornbrot, D., Msetfi, R., & Macrae. (2006). Joint model-parameter validation of self-estimates of valence and arousal: probing a differential-weighting model of affective intensity. (D. Kornbrot, R. Msetfi, & Macrae, Eds.) *Meeting of the Int. Society for Psychophysics*, 22, 245–250.
- Oppenheim, A. V., & Schafer., R. W. (1989). *Discrete-Time Signal Processing* (pp. 311–312). Englewood Cliffs, NJ: Prentice-Hall.
- Or, C. K. L., & Duffy, V. G. (2007). Development of a facial skin temperature-based methodology for non-intrusive mental workload measurement. *Occupational Ergonomics*, 7(2), 83–94.
- Ortiz, R. A., Schulte, J. K., Sparks, B., & Marsh, W. (2004). Prediction of different mandibular activities by EMG signal levels. *Journal of Oral Rehabilitation*, 31, 399–405.
- Ortony, A., & Turner, T. J. (1990). What’s basic about basic emotions. *Psychological Review*, 97(3), 315–331. doi:10.1037/0033-295X.97.3.315
- Osgood, C. E., Suci, G. J., & Tannenbaum, P. (1957). *The Measurement of Meaning (Urbana. University of Illinois Press*. University of Illinois Press.
- O’Haver, T. (2009). *Signal Processing Tools*. Maryland: Department of Chemistry and Biochemistry. The University of Maryland at College Park.

- Özbay, Y. (2008). A New Approach to Detection of ECG Arrhythmias: Complex Discrete Wavelet Transform Based Complex Valued Artificial Neural Network. *Journal of Medical Systems*, 33(6), 435–445. doi:10.1007/s10916-008-9205-1
- Pablo Laguna, Jané, R., Bogatell, E., & Anglada, D. V. (2000). ecgpuwave. PhysioNet.
- Pagon, M. (1996). Policing in Central and Eastern Europe: comparing firsthand knowledge with experience from the West. No.: ISBN 961-6230-00-X.
- Pahlm, O., & Sornmo, L. (1987). Data processing of exercise ECG's. *IEEE Transactions on Biomedical Engineering*, 34(2), 158–165.
- Palmore, E. (1982). Predictors of the longevity difference: a 25-year follow-up. *The Gerontologist*.
- Pan, J., & Tompkins, W. W. J. (1985). A real-time QRS detection algorithm. *IEEE Transactions on Biomedical Engineering*, 32(3), 230 – 236.
- Panksepp, J. (1982). Toward a general psychobiological theory of emotions. *Behavioral and Brain Sciences*, 5(3), 407–467.
- Pantic, M., & Rothkrantz, L. (2004). Case-based reasoning for user-profiled recognition of emotions from face images. *Multimedia and Expo, 2004. ICME '04. 2004 IEEE International Conference on*, 1, 391–394.
- Parrott, W. G. G. (2001). *Emotions in social psychology: Essential readings*. (W. G. Parrott, Ed.) (p. 378). Philadelphia: Psychology Press.
- Partala, T., & Surakka, V. (2003). Pupil size variation as an indication of affective processing. *International Journal of Human-Computer Studies*, 59(1-2), 185–198.
- Pasca, H., Pierre, L., & Henrique, S. (2005). Diurnal autonomic variations and emotional reactivity. *Biological Psychology*, 69(3), 261–70. doi:10.1016/j.biopsycho.2004.08.005
- Pauk, J. (2008). 419. Different techniques for EMG signal processing. *Signal Processing*.
- Penfield, W., & Rasmussen, T. (1950). *The Cerebral Cortex of Man*. New York: Macmillan.
- Peng, H., Long, F., & Ding, C. (2005). Feature selection based on mutual information: criteria of max-dependency, max-relevance, and min-redundancy. *IEEE Transactions on Pattern Analysis and Machine Intelligence*, 27(8), 1226–1238.
- Petty, R. E., Fabrigar, L. R., & Wegener, D. T. (2009). Emotional factors in attitudes and persuasion. In R. Davidson, K. Scherer, & H. Goldsmith (Eds.), *Handbook of Affective Sciences* (1st ed., pp. 752–772). New York: Oxford University Press.

- Philippot, P., Chappelle, G., & Blairy, S. (2002). Respiratory feedback in the generation of emotion. *Cognition & Emotion*, 16(5), 605–627.
- Phinyomark, A., Limsakul, C., & Phukpattaranont, P. (2009). A Novel Feature Extraction for Robust EMG Pattern Recognition. *Journal of Computing*, 1(1), 71–80.
- Picard, R. (2000). Toward computers that recognize and respond to user emotion. *IBM Systems Journal*, 39(3.4), 705–719.
- Picard, R., & Healey, J. (1998). Digital Processing of Affective Signals. *Acoustics, Speech and Signal Processing, 1998. Proceedings of the 1998 IEEE International Conference on*, 6, 3749 – 3752.
- Picard, R., & Healey, J. A. (2005a). Detecting Stress During Real-World Driving Tasks Using Physiological Sensors. *IEEE Transactions on Intelligent Transportation Systems*, 6(2), 156–166.
- Picard, R., & Healey, J. A. J. A. (2005b). Detecting stress during real-world driving tasks using physiological sensors. *Intelligent Transportation Systems, IEEE Transactions on*, 6(2), 156–166. doi:10.1109/TITS.2005.848368
- Picard, R. W. (1997). *Affective Computing*. Massachusetts: The MIT Press.
- Picard, R. W., & Klein, J. (2002). Computers that Recognise and Respond to User Emotion : Theoretical and Practical Implications. *Interacting with computers*, 1, 1–26.
- Picard, R. W., Vyzas, E., & Healey, J. (2001). Toward Machine Emotional Intelligence: Analysis of Affective Physiological State. *IEEE Transactions on Pattern Analysis and Machine Intelligence*, 23(10), 1175–1191.
- Pietrzak, R. H., Laird, J. D., Stevens, D. A., & Thompson, N. S. (2002). Sex differences in human jealousy:: A coordinated study of forced-choice, continuous rating-scale, and physiological responses on the same subjects. *Evolution and Human Behavior*, 23(2), 83–94.
- Pittermann, J., & Pittermann, A. (2006). A Post-Processing Approach to Improve Emotion Recognition Rates. *Signal Processing, 2006 8th International Conference on* (Vol. 1, pp. 1–4). IEEE. doi:10.1109/ICOSP.2006.345521
- Plutchik, R. (1980a). *Emotion, a psychoevolutionary synthesis* (p. 440). New York: Harpercollins College Div.
- Plutchik, R. (1980b). A general psychoevolutionary theory of emotion. *Emotion Theory, Research, and Experience*, 1, 3–31.
- Poppen, R., & Maurer, J. P. (1982). Electromyographic analysis of relaxed postures. *Applied Psychophysiology and Biofeedback*, 7(4), 491–498.

- Porto, W. G. (2005). *Normalization of 702 images set from the international affective picture system (iaps) in a brazilian elderly sample for emotion and attention testing (abstract)*. *Medicina*.
- Posner, J., Russell, J., & Peterson, B. (2005). The circumplex model of affect: An integrative approach to affective neuroscience, cognitive development, and psychopathology. *Developmental and Psychopathology*, *17*, 715–734.
- Post, R. M. (2009). Introduction: Emotion and Psychopathy. In R. Davidson, K. Scherer, & H. Goldsmith (Eds.), *Handbook of Affective Sciences* (1st ed., pp. 899–903). New York: Oxford University Press.
- Potse, M., Linnenbank, A. C., & Grimbergen, C. A. (1998). Matlab: An Extensible Software Package for Analysis of Multichannel ECG Recordings. *Engineering in Medicine and Biology Society, 1998. Proceedings of the 20th Annual International Conference of the IEEE*, *1*, 59 – 62.
- Pratt, J., & West, G. (2009). Emotion affects oculomotor action. *Journal of Vision*.
- Pratt, W. . (1978). *Digital Image Processing* (pp. 330–333). New York: John Wiley & Sons.
- Prendinger, H., & Ishizuka, M. (2004). What Affective Computing and Life-Like Character Technology Can Do for Tele-Home Health Care. *Workshop on HCI and Homecare: Connecting Families and Clinicians, in conj. with CHI-04* (pp. 1–3).
- Prineas, R., & Jacobs, D. (1980). Coffee, tea and VPB. *Journal of chronic diseases*.
- Prinz, J. J. (2004). *Gut reactions: A perceptual theory of emotion* (p. 271). New York: Oxford University Press, USA.
- Provaznik, I., Kozumplik, J., Bardonova, J., Novakova, M., & Novakova, Z. (2000). Wavelet Transform In ECG Signal Processing. *EuroConference BIOSIGNAL 2000* (pp. 1–5). Brno (Czech Republic).
- Purves, R. (1998). Human Electromyography. *Earth*, (February), 1–4.
- Qi, Y., & Picard, R. (2002). Context-sensitive Bayesian classifiers and application to mouse pressure pattern classification. *16th International Conference on Pattern Recognition (ICPR '02) - Volume 3* (p. 30448). Quebec.
- Quinlan, J. (1986). Induction of decision trees. *Machine learning*.
- Quinlan, J. (1993). *C4. 5: programs for machine learning*. Massachusetts: Morgan Kaufmann.
- Quinlan, P., Lane, J., & Aspinall, L. (1997). Effects of hot tea, coffee and water ingestion on physiological responses and mood: the role of caffeine, water and beverage type. *Psychopharmacology*, *134*(2), 164–173.

- Radin, D. (2000). Evidence for an anomalous anticipatory effect in the autonomic nervous system.
- Raghunathan, R., & Corfman, K. (2006). Is happiness shared doubled and sadness shared halved? Social influence on enjoyment of hedonic experiences. *Journal of Marketing Research*, 43(3), 386–394.
- Ramanathan, S., Kassim, A., Venkatesh, Y. V., & Wah, W. S. (2006). Human Facial Expression Recognition using a 3D Morphable Model. *Image Processing, 2006 IEEE International Conference on* (pp. 661–664). doi:10.1109/ICIP.2006.312417
- Rani, P., & Liu, C. (2006). An empirical study of machine learning techniques for affect recognition in human–robot interaction. *Pattern Analysis & Applications*.
- Rani, Pramila, Sarkar, N., & Smith, C. A. (2003). Affect-sensitive human-robot cooperation - theory and experiments. *Robotics and Automation, 2003. Proceedings. ICRA '03. IEEE International Conference on*, 2, 2382–2387.
- Rani, Pramila, Sims, J., Brackin, R., Sarkar, N., & Science, C. (2002). Online Stress Detection using Psychophysiological Signal for Implicit Human-Robot Cooperation. *Robotica*, 20, 673–686.
- Ratner, C. (1989). A social constructionist critique of the naturalistic theory of emotion. *The Journal of Mind and Behavior*, 10(3), 211–230.
- Ravaja, N., Kallinen, K., Saari, T., & Keltikangas-Järvinen, L. (2004). Suboptimal Exposure to Facial Expressions When Viewing Video Messages From a Small Screen: Effects on Emotion, Attention, and Memory. *Journal of Experimental Psychology: Applied*, 10(2), 120–13. doi:10.1037/1076-898X.10.2.120
- Ray, S., & Turi, R. H. (1999). Determination of Number of Clusters in K-Means Clustering and Application in Colour Image Segmentation. *Image (Rochester, N.Y.)*.
- Raya, M. A. D., & Sison, L. G. (2002). Adaptive noise cancelling of motion artifact in stress ECG signals using accelerometer. *Proceedings of the Second Joint EMBS/BMES Conference* (Vol. 2, pp. 1756–1757). Houston, Texas.
- Razak, A. A. A. A., Komiya, R., Izani, M., & Abidin, Z. (2005). Comparison between fuzzy and NN method for speech emotion recognition. *Information Technology and Applications, 2005. ICITA 2005. Third International Conference on*, 1(3), 0–297. doi:10.1109/ICITA.2005.101
- Revelle, W., Humphreys, M. S., & Simon, L. (1980). Journal of Experimental Psychology: General. *Journal of Experimental Psychology: General*, 109(1), 1–31.

- Richardson, K., Roberts, J., Gren, L., & Lyon, J. (1998). Cold hands, warm heart. *The Lancet*, 351(9114), 1492.
- Rimm, D., & Briddell, D. (1981). The effects of alcohol and the expectancy of alcohol on snake fear. *Addictive behaviors*.
- Rinn, W. E. (1984). The neuropsychology of facial expression: A review of the neurological and psychological mechanisms for producing facial expressions. *Psychological Bulletin*, 95(1), 52–77. doi:10.1037/0033-2909.95.1.52
- Rish, I. (2001). *IBM Technical Report RC22230: An empirical study of the naive Bayes classifier. IJCAI 2001 Workshop on Empirical Methods in Artificial* (pp. 41–46). Atlanta.
- Riskind, J. H., & Gotay, C. C. (1982). Physical posture: Could it have regulatory or feedback effects on motivation and emotion? *Motivation and Emotion*, 6(3), 273–298.
- Ritz, T., & Steptoe, A. (2000). Emotion and pulmonary function in asthma: Reactivity in the field and relationship with laboratory induction of emotion. *Psychosomatic Medicine*, 62(6), 808–815.
- Ritz, T., & Thöns, M. (2006). Affective modulation of swallowing rates: Unpleasantness or arousal? *Journal of psychosomatic research*, 61(6), 829–833.
- Rodgers, J., & Nicewander, A. (1988). Thirteen ways to look at the correlation coefficient. *American Statistician*, 42(1), 59–66.
- Rodrigues, A. D. C., Andreo, J. C., Menezes, L. D. F., Chinellato, T. P., & Marco Rosa, G. J. (2009). Anatomy of the Facial Nerve and its Implication in the Surgical Procedures. *International Journal of Morphology*, 27(1), 183–186. doi:10.4067/S0717-95022009000100031
- Rosaldo, M. Z. (1980). *Knowledge and passion: Ilongot notions of self and social life* (p. 286). Massachusetts: Cambridge University Press.
- Rosaldo, R. (1980). *Ilongot Headhunting, 1883-1974: A Study in Society and History* (p. 328). Stanford, CA: Stanford University Press.
- Ross, S. M. (2003). Peirce's criterion for the elimination of suspect experimental data. *Journal of Engineering Technology*, 20, 38–41.
- Rottenberg, J., Gross, J. J., Wilhelm, F. H., Najmi, S., & Gotlib, I. H. (2002). Crying threshold and intensity in major depressive disorder. *Journal of Abnormal Psychology*, 111(2), 302–312.
- Rottenberg, J., Ray, R. D., & Gross, J. J. (2007). Emotion elicitation using films. In J. Coan & J. Allen (Eds.), *The Handbook of Emotion Elicitation and Assessment* (1st ed., pp. 9–28). New York: Oxford University Press.

- Rozin, P. (2009). Introduction: Evolutionary and cultural perspectives on affect. In R. Davidson, K. Scherer, & H. Goldsmith (Eds.), *Handbook of Affective Sciences* (1st ed., pp. 839–851). New York: Oxford University Press.
- Russell, J. (1980). A circumplex model of affect. *Journal of personality and social psychology*.
- Russell, J. (2003). Core affect and the psychological construction of emotion. *Psychological review*, *110*(1), 145–172.
- Russell, J. A. (1991). Culture and the Categorization of Emotions. *Psychological Bulletin*, *110*, 426–450.
- Russell, J., & Mendelsohn, A. (1989). Affect Grid: A single-item scale of pleasure and arousal. *Journal of Personality and Social Psychology*, *57*(3), 493–502.
- Ryoo, D.-W., Kim, Y.-S., & Lee, J.-W. (2005). Wearable Systems for Service based on Physiological Signals. *Engineering in Medicine and Biology Society, 2005. IEEE-EMBS 2005. 27th Annual International Conference of the* (pp. 2437–2440). IEEE. doi:10.1109/IEMBS.2005.1616961
- SAS Institute Inc. (1999). The LOESS Procedure. *SAS/STAT® User's Guide, Version 8*, (pp. 1853–1901). Cary, NC.
- Sagie, A., Larson, M. G., Goldberg, R. J., & Bengtson, J. R. (1992). An improved method for adjusting the QT interval for heart rate (the Framingham Heart Study). *The American journal of cardiology*, *70*(7), 797–801.
- Salovey, P. (2009). Introduction: Emotion and social processes. In R. Davidson, K. Scherer, & H. Goldsmith (Eds.), *Handbook of Affective Sciences* (1st ed., pp. 747–751). New York: Oxford University Press.
- Salovey, P., Mayer, J. D., Goldman, S. L., Turvey, C., & Palfai, T. P. (1995). Emotional attention, clarity, and repair: Exploring emotional intelligence using the Trait Meta-Mood Scale. *Emotion, Disclosure, and Health*, (9058020), 125–154.
- Sandt, A. R., Sloan, D. M., & Kareem, J. (2009). Measuring appetitive responding with the postauricular reflex. *Psychophysiology*, *46*(3), 491–497.
- Sarkar, N. (2002). Psychophysiological control architecture for human-robot coordination-concepts and initial experiments. *Robotics and Automation, 2002. Proceedings. ICRA '02. IEEE International Conference on* (Vol. 4, pp. 0–3719). IEEE. doi:10.1109/ROBOT.2002.1014287
- Sarkar, Nilanjan. (2002). Psychophysiological Control Architecture for Human-Robot Coordination - Concepts and Initial Experiments. *Proceedings of the 2002 IEEE International Conference on Robotics & Automation*, (May).

- Sassenberga, K., & Moskowitzb, G. B. (2005). Don't stereotype, think different! Overcoming automatic stereotype activation by mindset priming. *Journal of Experimental Social Psychology*.
- Savitzky, A., & Golay, M. J. E. (1964). Smoothing and Differentiation of Data by Simplified Least Squares Procedures. *Analytical Chemistry*, 36(8), 1627–1639. doi:10.1021/ac60214a047
- Sayadi, O., & Shamsollahi, M. B. (2006). ECG denoising with adaptive bionic wavelet transform. *Engineering in Medicine and Biology Society, 2006. EMBS '06. 28th Annual International Conference of the IEEE, Suppl*, 6597–6600. doi:10.1109/IEMBS.2006.260897
- Sayette, M. A., Cohn, J. F., Wertz, J. M., Perrott, M. A., & Parrott, D. J. (2001). A psychometric evaluation of the facial action coding system for assessing spontaneous expression. *Journal of Nonverbal Behavior*, 25(3), 167–185.
- Saykrs, B. M. A. (1973). Analysis of heart rate variability. *Ergonomics*, 16(1), 17–32.
- Schaaff, K., & Schultz, T. (2008). *Challenges on Emotion Induction with the International Affective Picture System*. Universitat Karlsruhe (TH).
- Schachter, S., & Singer, J. E. (1962). Cognitive, social, and physiological determinants of emotional state. *Psychological Review*, 69(5), 379–399.
- Schefflen, A. (1972). *Body Language and the Social Order; Communication as Behavioral Control*. New Jersey: Prentice-Hall.
- Scheirer, J., Fernandez, R., Klein, J., & Picard, R. (2002). Frustrating the user on purpose: a step toward building an affective computer. *Interacting with computers*, 14(2), 93–118.
- Scheirer, J., Fernandez, R., & Picard, R. (1999). Expression glasses: a wearable device for facial expression recognition. *CHI'99 extended abstracts on Human factors in computing systems* (pp. 262–263). ACM.
- Scheirer, J., & Picard, R. (1999). Affective objects: Mit Media Laboratory Perceptual Computing Section Technical Report No. 524. *MIT Media Laboratory Perceptual Computing Section*. Boston.
- Schifferstein, H., Talke, K., & Oudshoorn, D. (2011). Can Ambient Scent Enhance the Nightlife Experience? *Chemosensory perception*.
- Schimmack, U., & Colcombe, S. (2001). Mixed Feelings : Toward a Theory of Pleasure and Displeasure. *Cognition & Emotion*, 15(1), 81–97.
- Schl, A., & Graz, T. (2004). SCP-Converter for Octave and Matlab. *Technology*.
- Schmidt, K. L., Ambadar, Z., Cohn, J. F., & Reed, L. I. (2006). Movement Differences between Deliberate and Spontaneous Facial Expressions:

- Zygomaticus Major Action in Smiling. *Journal of Nonverbal Behavior*, 30(1), 37–52. doi:10.1007/s10919-005-0003-x
- Schneider, A., & Leitenbauer, M. (2010). Effects of Picture Modification on Emotional Impact. *Proceedings of the 7th International Conference on Design & Emotion*, 7, 114–126.
- Schneider, C., & Wilson, E. (1985). Special considerations for EMG biofeedback. *Foundations of Biofeedback Practice*. Biofeedback Society of America.
- Schneider, E., Lang, A., Shin, M., & Bradley, S. D. (2004). Death with a Story. *Human Communication Research*, 30(3), 361–375.
- Schuller, B., Arsic, D., Wallhoff, F., Lang, M., & Rigoll, G. (2005). Bioanalog Acoustic Emotion Recognition by Genetic Feature Generation Based on Low-Level-Descriptors. *Computer as a Tool, 2005. EUROCON 2005. The International Conference on* (Vol. 2, pp. 1292–1295). IEEE. doi:10.1109/EURCON.2005.1630194
- Schuller, Bjom, Arsic, D., Wallhoff, F., Lang, M., Rigoll, G., & Members, S. (2005). Emotion Recognition. *Corpus*, 00, 1292–1295.
- Schuller, Bjom, Rigoll, G., & Lang, M. (2004). Emotion recognition in the manual interaction with graphical user interfaces. *Multimedia and Expo, 2004. ICME '04. 2004 IEEE International Conference on*, 2, 1215–1218. doi:10.1109/ICME.2004.1394440
- Schwartz, G. E., Fair, P. L., Salt, P., Madel, M. R., & Klerman, G. . (1976). Facial Muscle Patterning to Affective Imagery in Depressed and Nondepressed Subjects. *Science, New Series*, 192(4238), 489–491.
- Schwarz, N. (2000). Emotion, cognition, and decision making. *Cognition & Emotion*, 14(4), 433–440.
- Scotti, S., Mauri, M., Cerutti, S., Mainardi, L., & Villamira, M. (2005). Quantitative evaluation of distant student psychophysical responses during the e-learning processes. *Engineering in Medicine and Biology Society, 2005. IEEE-EMBS 2005. 27th Annual International Conference of the* (pp. 1196–1199). IEEE. doi:10.1109/IEMBS.2005.1616638
- Scotti, Stefano, Mauri, M., Barbieri, R., Jawad, B., Cerutti, S., Mainardi, L., Brown, E. N., et al. (2006). Automatic Quantitative Evaluation of Emotions in E-learning Applications. *Engineering in Medicine and Biology Society, 2006. EMBS '06. 28th Annual International Conference of the IEEE* (pp. 1359–1362). IEEE. doi:10.1109/IEMBS.2006.260601
- Sebe, N, Cohen, I., Gevers, T., & Huang, T. S. (2005). Multimodal approaches for emotion recognition: A survey. *Proceedings series SPIE (the international society for optics and photonics), SPIE-5670*, 56–67.

- Sebe, N, Lew, M., Cohen, I., Garg, A., & Huang, T. S. (2002). Emotion recognition using a cauchy naive Bayes classifier. *16th International Conference on Pattern Recognition (ICPR'02) - Volume 1* (p. 10017). Quebec.
- Sebe, Nicu, Cohen, I., Gevers, T., & Huang, T. S. (2006). Emotion Recognition Based on Joint Visual and Audio Cues. *Pattern Recognition* (pp. 1136–1139). HongKong: IEEE Computer Society. doi:10.1109/ICPR.2006.489
- Segal, M. R., & Segal, M. R. (2004). *Machine Learning Benchmarks and Random Forest Regression*. San Francisco: Center for Bioinformatics & Molecular Biostatistics.
- Seifritz, E., Dammann, G., Martin-Soelch, C., & Scheffler, K. (2001). *Borderline Personality Disorder Research Foundation* (pp. 1–9). Basel.
- Seppänen, T. (1999). Spectral estimation of biosignals I [course notes 521273S Biosignal Processing]. *Processing*. Oulu: University of Oulu.
- Shah, J., & Kruglanski, A. (2002). A theory of goal systems. *Advances in experimental social psychology*, *34*, 331–378.
- Shaman, P. (2010). Generalized Levinson–Durbin Sequences, Binomial Coefficients and Autoregressive Estimation. *Journal of Multivariate Analysis*.
- Shannon, C. (1948). A mathematical theory of communication. *Bell System Technical Journal*, *27*, 379–423, 623–65.
- Shannon, C. (1951). Prediction and entropy of printed English. *Bell System Technical Journal*.
- Shelley, K., & Shelley, S. (2001). Pulse oximeter waveform: photoelectric plethysmography. (C. Lake, R. Hines, & C. Blitt, Eds.) *Clinical monitoring practical applications for anesthesia and critical care*. W.B. Saunders.
- Short, N. M. (2010). The Remote Sensing Tutorial. Retrieved from <http://rst.gsfc.nasa.gov/>
- Shouldice, R., & Heneghan, C. (2001). *Analysis of Transient Changes in Heart Rate*. National University of Ireland.
- Siegle, G. J., Steinhauer, S. R., Carter, C. S., Ramel, W., & Thase, M. E. (2003). Do the seconds turn into hours? Relationships between sustained pupil dilation in response to emotional information and self-reported rumination. *Cognitive Therapy and Research*, *27*(3), 365–382.
- Silipo, R., Laguna, P., Narchesi, C., & Mark, R. G. (1995). ST-T segment change recognition using artificial neural networks and principal component analysis. *Computers in Cardiology*, 213–216.

- Silipo, R., & Marchesi, C. (1998). Artificial Neural Networks for Automatic ECG Analysis. *Signal Processing, IEEE Transactions on*, 46(5), 1417 – 1425.
- Silvia, P. J., & Phillips, A. G. (2004). Self-awareness, self-evaluation, and creativity. *Personality and Social Psychology*.
- Sinha, R. (1996). Multivariate response patterning of fear and anger. *Cognition & Emotion*.
- Sirota, A. D., & Schwartz, G. E. (1982). Facial muscle patterning and lateralization during elation and depression imagery. *Journal of Abnormal Psychology*, 91(1), 25–34. doi:10.1037/0021-843X.91.1.25
- Sloan, D. M., Bradley, M. M., Dimoulas, E., & Lang, P. J. (2002). Looking at facial expressions: Dysphoria and facial EMG. *Biological Psychology*, 60, 79–90.
- Sloan, D. M., Strauss, M. E., Quirk, S. W., & Sajatovic, M. (1997). Subjective and expressive emotional responses in depression. *Journal of Affective Disorders*, 46, 135–141.
- Smith, A. P., Rusted, J. M., Savory, M., Eaton-Williams, P., & Hall, S. R. (1991). The effects of caffeine, impulsivity and time of day on performance, mood and cardiovascular function. *Journal of Psychopharmacol*, 5(2), 120–128. doi:10.1177/026988119100500205
- Snyder, A., Weste, N., Le, T., & Do., N. (2010). Emotiv - Brain Computer Interface Technology. Retrieved September 6, 2010, from <http://www.emotiv.com/>
- Spangler, G., Emlinger, S., Meinhard, J., & Hamm, A. (2001). The specificity of infant emotional expression for emotion perception. *International Journal of Psychophysiology*, 41(2), 155–168.
- Springs, C. (1993). Neural network recognition of human face images stored in the database. *Computers and Communications, Twelfth Annual International Phoenix Conference on*. (pp. 552–558).
- Standring, S., & Gray, H. (2008). *Gray's Anatomy: The Anatomical Basis of Clinical Practice, Expert Consult - Online and Print, 40e* (p. 1576). Churchill Livingstone.
- Stein, N. L., & Oatley, K. (1992). Basic emotions: Theory and measurement. *Cognition & Emotion*, 6(3), 161–168.
- Stekelenburg, J., & Boxtel, A. (2002). Pericranial muscular, respiratory, and heart rate components of the orienting response. *Psychophysiology*, 39(6), 707–722.
- Stemmler, G. (2003). Methodological considerations in the psychophysiological study of emotion. *Handbook of affective sciences*.

- Stevens, P. (2001). Effects of 5 s exposures to a 50 μ T, 20 Hz magnetic field on skin conductance and ratings of affect and arousal. *Bioelectromagnetics*, 22(4), 219–223.
- Strack, F., Martin, L., & Stepper, S. (1988). Inhibiting and facilitating conditions of the human smile: a nonobtrusive test of the facial feedback hypothesis.pdf (application/pdf object). *Journal of Personality and Social Psychology*, 54(5), 768–777.
- Strapparava, C., & Valitutti, A. (2004). WordNet-Affect: an affective extension of WordNet. *Proceedings of LREC* (pp. 1083–1086). Lisbon, Portugal.
- Strauss, M., Reynolds, C., Hughes, S., Park, K., McDarby, G., & Picard, R. (2005). The handwave bluetooth skin conductance sensor. *Affective Computing and Intelligent Interaction*, 1, 699–706.
- Strongman, K. (2005). Emotion. *Psychology* (pp. 112–133).
- Su, L., & Zhao, G. (2005). De-noising of ECG signal using translation-Invariant wavelet de-noising method with improved thresholding. *Engineering in Medicine and Biology Society, 2005. IEEE-EMBS 2005. 27th Annual International Conference of the* (pp. 5946–5949). IEEE.
- Sucontphunt, T., Yuan, X., Li, Q., & Deng, Z. (2008). A Novel Visualization System for Expressive Facial Motion Data Exploration. *Visualization Symposium, 2008. PacificVIS '08. IEEE Pacific* (pp. 103–109). IEEE.
doi:10.1109/PACIFICVIS.2008.4475465
- Sun, K., Yu, J., Huang, Y., & Hu, X. (2009). An improved valence-arousal emotion space for video affective content representation and recognition. *IEEE International Conference on Multimedia and Expo, 09*, 566–569.
- Sung, H. (2007). Emotion Interaction System for a Service Robot 1. *New York*, 351–356.
- Surakka, V., & Anttonen, J. (2005). Emotions and heart rate while sitting on a chair. *SIGCHI conference on Human factors in computing systems (CHI05)*, 491–499.
doi:10.1145/1054972.1055040
- Sutton, S. K., Davidson, R. J., Donzella, B., Irwin, W., & Dotts, D. (1997). Manipulating Affective State Using Extended Picture Presentations. *Psychophysiology*, 34, 217–226.
- Swindells, C., Maclean, K. E., Booth, K. S., Meitner, M. J., Keywords, A., & Keywords, A. C. M. C. (2007). Exploring Affective Design for Physical Controls. *CHI '07: Proceedings of the SIGCHI conference on Human factors in computing systems* (pp. 933–942). New York, NY, USA: ACM Press.

- Sykes, J., & Brown, S. (2003). Affective gaming: measuring emotion through the gamepad. *CHI'03 extended abstracts on Human factors in computing systems* (pp. 732–733). ACM.
- Takahashi, K. (2004). Remarks on emotion recognition from bio-potential signals. *The Second International Conference on Autonomous Robots and Agents* (pp. 186–191).
- Talbot, J., & Lee, B. (2009). EnsembleMatrix: interactive visualization to support machine learning with multiple classifiers. *Proceedings of the 27th international conference on Human factors in computing systems (CHI09)*, 1283–1292.
- Tan, P.-N., Steinbach, M., & Kumar, V. (2005). *Introduction to Data Mining* (p. 500). Boston: Addison-Wesley.
- Tang, Y., Zhang, Y. Q., Chawla, N. V., & Krasser, S. (2009). SVMs modeling for highly imbalanced classification. *Systems, Man, and Cybernetics, Part B: Cybernetics, IEEE Transactions on*, 39(1), 281–288.
- Tassinary, L. G., Cacioppo, J. T., & Geen, T. R. (1989). A Psychometric Study of Surface Electrode Placements for Facial Electromyographic Recording: I. The Brow and Cheek Muscle Regions. *Psychophysiology*, 26(1), 1–16.
doi:10.1111/j.1469-8986.1989.tb03125.x
- Tenedero, C. M., Raya, M. A. D., & Sison, L. G. (2002). Design and implementation of a single-channel ecg amplifier with DSP post-processing in matlab. *Third National Electronics & Engineering Conference*.
- Thakor, N. V., Webster, J. G., & Tompkins, W. J. (1984). Estimation of QRS Complex Power Spectra for Design of a QRS Filter. *Biomedical Engineering, IEEE Transactions on*, 31(11), 702 – 706. doi:10.1109/TBME.1984.325393
- Thought Technology Ltd. (2003). *ProComp Infiniti™ Hardware Manual. Technology* (Vol. 1, p. 40). Montreal: Thought Technology ltd.
- Toda, M. (1980). Emotion and decision making. *Acta Psychologica*, 45(1-3), 133–155.
- Tomkins, S. (1984). Affect theory. In K. R. Scherer & P. Ekman (Eds.), *Approaches to emotion* (pp. 163–195).
- Tosello, D. O., Vitti, M., & Berzin, F. (1999). EMG activity of the orbicularis oris and mentalis muscles in children with malocclusion, incompetent lips and atypical swallowing--part II. *Journal of oral rehabilitation*, 26(8), 644–9.
- Trimmel, M., Meixner-Pendleton, M., & Haring, S. (2003). Stress response caused by system response time when searching for information on the Internet. *Human Factors: The Journal of the Human Factors and Ergonomics Society Winter 2003*, 45(4), 615–622.

- Tsai, J. L. (1997). Cultural Influences on Emotional Responding. *Journal of Cross-Cultural Psychology*, 28(5), 600–625.
- Tsihrintzis, G. A. G. A., Virvou, M., Alepis, E., & Stathopoulou, I.-O. I. O. (2008). Towards Improving Visual-Facial Emotion Recognition through Use of Complementary Keyboard-Stroke Pattern Information. *Information Technology: New Generations, 2008. ITNG 2008. Fifth International Conference on* (pp. 32–37). IEEE. doi:10.1109/ITNG.2008.152
- Tsonos, D., Xydias, G., & Kouroupetroglou, G. (2007). A Methodology for Reader's Emotional State Extraction to Augment Expressions in Speech Synthesis. *Tools with Artificial Intelligence, 2007. ICTAI 2007. 19th IEEE International Conference on* (Vol. 2, pp. 218–225). doi:10.1109/ICTAI.2007.21
- Tsonos, Dimitrios, & Kouroupetroglou, G. (2007). A Methodology for the Extraction of Reader ' s Emotional State Triggered from Text Typography. *Assessment*.
- Tsunami, D., Mcnames, J., Aboy, M., & Ellenby, M. S. (2003). A New Resource for Independent and Blinded Assessment of QRS Detection Algorithms. *Computer Engineering*, 2889–2892.
- Turkia, M. (2009). A Computational Model of Affects. In D. Dietrich, G. Fodor, G. Zucker, & D. Bruckner (Eds.), *Simulating the Mind (A Technical Neuropsychanalytical Approach)* (1st ed., pp. 277–283). New York: Springer-Verlag/Wien.
- Tzvetanova, S., Tang, M., Justice, L., Hofmann, A., Beyer, I., Guenther, C., & Holzwarth, F. (2007). Emotional Web Usability Evaluation. *Lecture Notes in Computer Science. Human-Computer Interaction. HCI Applications and Services* (pp. 1039–1046). Springer.
- UN General Assembly Universal Declaration of Human Rights (1948). UN General Assembly.
- Univenity, D. (2004). Case-based reasoning for user-profiled recognition of emotions from face images. *Search*, 391–394.
- Usuki, K., Kanekura, T., Aradono, K., & Kanzaki, T. (1998). Effects of nicotine on peripheral cutaneous blood flow and skin temperature. *Journal of dermatological science*, 16(3), 173–181.
- Vaiman, M., Eviatar, E., & Segal, S. (2004). Surface electromyographic studies of swallowing in normal subjects: a review of 440 adults. Report 1. Quantitative data: timing measures. *Otolaryngology–Head and Neck Surgery*, 131(4), 548.
- Van Alste, J., & Schilder, T. (1985). Removal of base-line wander and power-line interference from the ECG by an efficient FIR filter with a reduced number of taps. *Biomedical Engineering, IEEE Transactions on*, (12), 1052–1060.

- Van Boxtel, A., & Jessurun, M. (1993). Amplitude and bilateral coherency of facial and jaw-elevator EMG activity as an index of effort during a two-choice serial reaction task. *Psychophysiology*, *30*, 589–589.
- Van Der Maaten, L., & Hinton, G. (2008). Visualizing Data using t-SNE. *Journal of Machine Learning Research*, *9*, 2579–2605.
- Van Der Maaten, L., Postma, E., & van Den Herik, J. (2009). *Dimensionality Reduction : A Comparative Review*. October. Tilburg.
- VanDenBroek, E. L., Lisy, V., Westerink, J., Schut, M. H., & Tuinenbreijer, K. (2009). Biosignals as an Advanced Man-Machine Interface. *BIOSTEC International Joint Conference on Biomedical Engineering Systems and Technologies*, (pp. 15–24).
- Vautier, S., Neves, R. D. A., Martinot, C., & Ruiz, R. (2001). Impact of affective pictures on state and trait anxiety assessed with the French STAI-Y. *Anxiety*, *1*–11.
- Veltman, J. (1996). *Physiological workload reactions to increasing levels of task difficulty*.
- Velásquez, J. D. (1997). Modeling emotions and other motivations in synthetic agents. *PROCEEDINGS OF THE NATIONAL CONFERENCE ON ARTIFICIAL INTELLIGENCE* (pp. 10–15). Rhode Isand: Citeseer.
- Verona, E., Patrick, C. J., Curtin, J. J., Bradley, M. M., & Lang, P. J. (2004). Psychopathy and Physiological Response to Emotionally Evocative Sounds. *Journal of Abnormal Psychology*, *113*(1), 99–108. doi:10.1037/0021-843X.113.1.99
- Verschuere, B. (2001). The international affective picture system: a cross cultural validation study. *Psychologica belgica*.
- Verschuere, B. (2007). Cross cultural validation of the IAPS. *Ghent Belgium Ghent University*.
- Vesterinen, E. (2001). Affective Computing. *Digital Media Research Seminar* (pp. 1–11).
- Vig, P. S. (1985). Respiration, nasal airway, and orthodontics: A review of current clinical concepts and research. *New vistas in orthodontics*, 76–102.
- Villon, O., & Lisetti, C. (2006). A User-Modeling Approach to Build User's Psycho-Physiological Maps of Emotions using Bio-Sensors. *Robot and Human Interactive Communication, 2006. ROMAN 2006. The 15th IEEE International Symposium on* (pp. 269–276). IEEE. doi:10.1109/ROMAN.2006.314429
- Villon, O., & Lisetti, C. (2007). Toward Recognizing Individual's Subjective Emotion from Physiological Signals in Practical Application. *Computer-Based Medical*

- Systems, 2007. CBMS '07. Twentieth IEEE International Symposium on* (pp. 357–362). IEEE. doi:10.1109/CBMS.2007.112
- Villon, Olivier, & Lisetti, C. (2006). A User-Modeling Approach to Build User's Psycho-Physiological Maps of Emotions using Bio-Sensors. *Hypertension*, 269–276.
- Villon, Olivier, & Lisetti, C. (2007). Toward Recognizing Individual's Subjective Emotion from Physiological Signals in Practical Application. *Symposium A Quarterly Journal In Modern Foreign Literatures*, 0–5.
- Vinson, J. E., & Liou, J. J. (1998). Electrostatic discharge in semiconductor devices: an overview. *Proceedings of the IEEE*.
- Vrana, S.R. (1995). Emotional modulation of skin conductance and eyeblink responses to a startle probe. *Psychophysiology*, 32(4), 351–357.
- Vrana, S.R., & Rollock, D. (2002). The role of ethnicity, gender, emotional content, and contextual differences in physiological, expressive, and self-reported emotional responses to imagery. *Cognition and Emotion*, 16(1), 165–192.
- Vrana, S.R., Spence, E. L., & Lang, P. J. (1988). The startle probe response: A new measure of emotion. *Journal of Abnormal Psychology*, 97(4), 487–491.
- Vrana, Scott R. (1993). The psychophysiology of disgust: Differentiating negative emotional contexts with facial EMG. *Psychophysiology* May93, 30(3).
- Vuk, M., & Curk, T. (2006). ROC Curve, Lift Chart and Calibration Plot. *Metodoloski zvezki*, 3(1), 89–108.
- Vuskovic, M., & Du, S. (2001). Classification of Prehensile EMG Patterns With Simplified Fuzzy ARTMAP Networks. *International Joint Conference on Neural Networks* (Vol. 3, pp. 2539– 2544).
- Vuskoviv, M. I., Pozos, A. L., & Pozos, R. (1995). Classification of Grasp Modes Based on Electromyographic Patterns of Preshaping Motions. *Systems, Man and Cybernetics, 1995. Intelligent Systems for the 21st Century., IEEE International Conference on*, 1, 89–95.
- Vyas, E. (1999). *Regocnition of Emotional Cognitive States Using Physiological Data*. MIT (Massachusetts Institute of Technology).
- Wager, T. D., Phan, K. L., Liberzon, I., & Taylor, S. F. (2003). Valence, gender, and lateralization of functional brain anatomy in emotion: a meta-analysis of findings from neuroimaging. *NeuroImage*, 19, 513–531.
- Wagner, J., Andre, E., Kim, J., & Andr, E. (2005). From Physiological Signals to Emotions: Implementing and Comparing Selected Methods for Feature Extraction and Classification. *2005 IEEE International Conference on Multimedia and Expo* (pp. 940–943). IEEE. doi:10.1109/ICME.2005.1521579

- Wahab, A., Wen, T. G., Kamaruddin, N., Cerebellar, K., Articulation, M., & Cmac, C. (2007). Understanding driver behavior using multi-dimensional CMAC. *Information, Communications & Signal Processing, 2007 6th International Conference on* (pp. 1–5). IEEE. doi:10.1109/ICICS.2007.4449860
- Wallbott, H. G. (1998). Bodily expression of emotion. *European journal of social psychology, 28*(6), 879–896.
- Wang, P. S. P. S. P. (2007). Biometrics Intelligence Information Systems and Applications. *Bioinformatics and Bioengineering, 2007. BIBE 2007. Proceedings of the 7th IEEE International Conference on* (p. 1454). IEEE. doi:10.1109/BIBE.2007.4375772
- Wang, Y., & Makedon, F. (2004). Application of Relief-F feature filtering algorithm to selecting informative genes for cancer classification using microarray data. *Computational Systems Bioinformatics Conference, 2004. CSB 2004. Proceedings. 2004 IEEE* (pp. 497–498). IEEE.
- Ward, R. (2004). An analysis of facial movement tracking in ordinary human-computer interaction. *Interacting with Computers, 16*(5), 879–896.
- Warlar, R., & Eswaran, C. (1991). Integer coefficient bandpass filter for the simultaneous removal of baseline wander, 50 and 100 Hz interference from the ECG. *Medical and Biological Engineering and Computing, 29*(3), 333–336.
- Watson, D., Clark, L., & Tellegen, A. (1988). Development and validation of brief measures of positive and negative affect. *Journal of Personality and Social Psychology, 54*(6), 1063–1070.
- Waynbaum, I. (1907). *La Physionomie Humaine. Son Me'canisme et son R6le Social.*
- We, G. (1985). Signal Acquisition. *Engineering In Medicine And Biology.*
- Wehrle, T. (1998). Motivations Behind Modeling Emotional Agents: Whose Emotion Does Your Robot Have? *Grounding Emotions in Adaptive Systems (5th International Conference of the Society for Adaptive Behavior Workshop Notes (SAB '98)), 5.*
- Wei, H., & Jeoti, V. (2004). *ECG signal processing with wavelet footprints.* Universiti Teknologi Petronas, Seri Iskandar.
- Weitz, M. (2006). *Messung und Analyse myoelektrischer Signale.* University of Kassel.
- Welch, P. (1967). The use of fast Fourier transform for the estimation of power spectra: a method based on time averaging over short, modified periodograms. *Audio and Electroacoustics, IEEE Transactions on, 15*(2), 70–73.
- Werbos, P. (1974). *Beyond regression: New tools for prediction and analysis in the behavioral sciences.* Harvard University.

- Westerink, J., Broek, E., & Schut, M. (2008). Computing emotion awareness through galvanic skin response and facial electromyography. *Probing* .
- Westerink, J. H. D. M., Egon, V. D. B., Marleen, H. S., Herk, J. V., & Tuinenbreijer, K. (2007). Computing Emotion Awareness Through Galvanic Skin Response and Facial Electromyography. *Probing Experience From Assessment of User Emotions and Behaviour to Development of Products* (1st ed., pp. 149–162). Springer Netherlands.
- Wickens, C. D., Gordon, S. E., & Liu, Y. (2004). *An introduction to human factors engineering*. New Jersey: Pearson Prentice Hall Upper Saddle River, NJ.
- Widrow, B., & Hoff, M. (1960). Adaptive Switching Circuits. *Institute of Radio Engineers (IRE) Wescon Convention Record* (pp. 4: 96–104).
- Williams, L. E., & Bargh, J. A. (2008). Experiencing Physical Warmth Promotes Interpersonal Warmth. *Science (New York, N.Y.)*, 322(5901), 606–7. doi:10.1126/science.1162548
- Williamson, S., Harpur, T. J., & Hare, R. P. (1991). Abnormal Processing of Affective Words by Psychopaths. *Psychophysiology*, 28(3), 260–273.
- Willibald, R., & Ekman, P. (2001). THE EXPRESSIVE PATTERN OF LAUGHTER. *The International Summer School and Symposium on Humour and Laughter: Theory, Research and Applications*.
- Wilson, V. (2004). The effects of upright and slumped postures on the recall of positive and negative thoughts. *Applied psychophysiology and biofeedback*.
- Winkel, J. D., Younger, J. W., Tomcika, N., Borckardtc, J. J., & Nash, M. R. (2006). Anatomy of a hypnotic response: Self-report estimates, actual behavior, and physiological response to the hypnotic suggestion for arm rigidity. *International Journal of Clinical and Experimental Hypnosis*, 54(2), 186–205.
- Winkielman, P., & Berridge, K. C. (2004). Unconscious Emotion. *Current Directions in Psychological Science*, 13(3), 120–123. doi:10.1111/j.0963-7214.2004.00288.x
- Winkielman, Piotr, & Cacioppo, J. T. (2001). Mind at Ease Puts Smile on Face: Psychophysiological Evidence that Processing Facilitation Elicits Positive Affect. *Journal of Personality and Social Psychology*, 81(6), 989–1000.
- Winkler, S. M., Affenzeller, M., & Wagner, S. (2006). Sets of receiver operating characteristic curves and their use in the evaluation of multi-class classification. *Proceedings of the Genetic and Evolutionary Computation Conference* (Vol. 2, pp. 1601–1602). Citeseer.
- Winton, W. M., Putnam, L. E., & Krauss, R. M. (1984). Facial and autonomic manifestations of the dimensional structure of emotion. *Journal of Experimental Social Psychology*, 20(3), 195–216.

- Wise, K., & Kim, H. J. (2008). Searching versus surfing: how different ways of acquiring content online affect cognitive processing. *Cyberpsychology & behavior : the impact of the Internet, multimedia and virtual reality on behavior and society*, 11(3), 360–2. doi:10.1089/cpb.2007.0130
- Witten, I. H., & Frank, E. (2005). *Data Mining: Practical Machine Learning Tools and Techniques, Second Edition (Morgan Kaufmann Series in Data Management Systems)*. (J. Gray, Ed.) (2nd ed., p. 560). San Francisco: Morgan Kaufmann.
- Wolf, K., Mass, R., Ingenbleek, T., Kiefer, F., Naber, D., & Wiedemann, K. (2005). The facial pattern of disgust, appetite, excited joy and relaxed joy: an improved facial EMG study. *Scandinavian journal of psychology*, 46(5), 403–9. doi:10.1111/j.1467-9450.2005.00471.x
- Wong, T. W., Chen, C. H., Huang, C. C., Lin, D. C., & Hui, S. W. (2006). Painless electroporation with a new needle-free microelectrode array to enhance transdermal drug delivery. *Journal of Controlled Release*, 110(3), 557–565.
- Wouda, J. (2006). Experimental Tests of Normative Group Influence and Representation Effects in Computer Mediated Communication. *Human Communication Research*.
- Woznica, A., Kalousis, A., Schanstra, J., & Klein, J. (2010). e-LICO multi-omics prediction challenge. Retrieved November 18, 2010, from <http://tunedit.org/challenge/ON>
- Yang, J., Xu, M., Zhao, W., & Xu, B. (2009). A Multipath Routing Protocol Based on Clustering and Ant Colony Optimization for Wireless Sensor Networks. *Sensors (Peterborough)*, 10(October), 4521–4540. doi:10.3390/s100504521
- Yang, R., & Liu, G. (2007). Emotion Feature Selection from Physiological Signal Based on BPSO. *Proceedings on Intelligent Systems and Knowledge Engineering (ISKE2007)*, 3–6. doi:10.2991/iske.2007.130
- Yang, Y., & Wei, Y. (2010). Random interpolation average for signal denoising. *Signal Processing, IET*, 4(6), 708–719.
- Yannakakis, G. N., & Hallam, J. (2008). Entertainment modeling through physiology in physical play. *International Journal of Human-Computer Studies*, 66(10), 741–755.
- Yoo, S., Lee, C., Park, Y., & Kim, N. (2005). Neural network based emotion estimation using heart rate variability and skin resistance. *Advances in Natural* .
- Yu, C., Liu, Z., McKenna, T., Reisner, A. T., & Reifman, J. (2006). A method for automatic identification of reliable heart rates calculated from ECG and PPG waveforms. *Journal of the American Medical Informatics Association*, 13(3), 309.

- Yuankui, Y., & Jianzhong, Z. (2005). Recognition and analyses of EEG & ERP signals related to emotion: from the perspective of psychology. *Neural Interface and Control* (pp. 96–99). IEEE. doi:10.1109/ICNIC.2005.1499851
- Zadražil, M., & Kozumplík, J. (2003). Wavelet filtering with median thresholds. *Microwave and Radio Electronics Week, 13*(5), 1–4.
- Zajonc, R. B. (1985). Emotion and facial efference: a theory reclaimed. *Science*, 228(4695), 15–21.
- Zajonc, R. B., Murphy, S. T., & Inglehart, M. (1989). Feeling and facial efference: implications of the vascular theory of emotion. *Psychological review*, 96(3), 395–416.
- Zelenski, J. M., & Larsen, R. J. (2000). The Distribution of Basic Emotions in Everyday Life: A State and Trait Perspective from Experience Sampling Data. *Journal of Research in Personality*, 34(2), 178–197.
- Zeman, J., & Garber, J. (1996). Display rules for anger, sadness, and pain: It depends on who is watching. *Child Development*, 67(3), 957–973.
- Zeng, Z., Fu, Y., Roisman, G. I., Wen, Z., Hu, Y., & Huang, T. S. (2006). One-Class Classification for Spontaneous Facial Expression Analysis. *Automatic Face and Gesture Recognition, 2006. FGR 2006. 7th International Conference on* (pp. 281–286). Washington, DC, USA: IEEE Computer Society. doi:10.1109/FGR.2006.83
- Zhai, J., & Barreto, A. (2008). Stress detection in computer users through non-invasive monitoring of physiological signals. *Blood*, 5, 0.
- Zhai, Jing, & Barreto, A. (2006a). Stress Recognition Using Non-Invasive Technology. *Proceedings of the 19th International Florida Artificial Intelligence Research Society Conference FLAIRS*, 395–400.
- Zhai, Jing, & Barreto, A. (2006b). Stress Detection in Computer Users Based on Digital Signal Processing of Noninvasive Physiological Variables. *Engineering in Medicine and Biology Society, 2006. EMBS '06. 28th Annual International Conference of the IEEE* (pp. 1355–1358). IEEE. doi:10.1109/IEMBS.2006.259421
- Zhai, Jing, Barreto, A. B. A. B. B., Chin, C., & Li, C. (2005). Realization of stress detection using psychophysiological signals for improvement of human-computer interactions. *SoutheastCon, 2005. Proceedings. IEEE* (pp. 415–420). IEEE. doi:10.1109/SECON.2005.1423280
- Zhang, G. (2000). Neural Networks for Classification: A Survey. *IEEE Transactions on Systems, Man, and Cybernetics, Part C: Applications and Reviews*, 30(4), 451–462.

- Zhang, H. (2004). The Optimality of Naive Bayes. In V. Barr & M. Zdravko (Eds.), *Proceedings of the Seventeenth International Florida Artificial Intelligence Research Society Conference : FLAIRS2004*. Florida: AAAI Press.
- Zhang, M., & Zhou, Z. (2007). ML-KNN: A lazy learning approach to multi-label learning. *Pattern Recognition*, 40(7), 2038–2048.
doi:10.1016/j.patcog.2006.12.019
- Zhang, Y, Post, W., & Dalal, D. (2011). Coffee, alcohol, smoking, physical activity and QT interval duration: results from the Third National Health and Nutrition Examination Survey. *PLoS one*.
- Zhang, Y., Li, Z., Ren, F., & Kuroiwa, S. (2005). Semi-automatic emotion recognition from textual input based on the constructed emotion thesaurus. *Natural Language Processing and Knowledge Engineering, 2005. IEEE NLP-KE '05. Proceedings of 2005 IEEE International Conference on* (pp. 571–576).
doi:10.1109/NLPKE.2005.1598802
- Zhang, Yu, Li, Z., Ren, F., & Kuroiwa, S. (2005). Semi-automatic Emotion Recognition from Textual Input Based on the Constructed Emotion Thesaurus. *IEEE International Conference on Natural Language Processing, 1*, 571–576.
- Zimmermann, P., Guttormsen, S., Danuser, B., & Gomez, P. (2003). Affective Computing – A Rationale for Measuring Mood with Mouse and Keyboard. *Swiss Federal Institute of Technology*, 1–10.
- Zimmermann, P., & Guttormsen-Schär, S. (2003). Affective Computing – Measuring Mood with Mouse and Keyboard. *International Journal of Occupational Safety and Ergonomics (JOSE)*, 9(4), 539–551.
- Zwaag, M. D. V. D. (2010). Guidelines for biosignal-driven HCI. *CHI (ACM Conference on Human Factors in Computing Systems) 2010*, 1–4.
- de Gelder, B., & Hadjikhani, N. (2006). Non-conscious recognition of emotional body language. *Neuroreport*, 17(6), 583.
- de Wied, M., & Verbaten, M. N. (2001). Affective Pictures Processing, Attention, and Pain Tolerance. *Pain*.
- van den Broek, E. L., Janssen, J. H., Healey, J. A., & van der Zwaag, M. D. (2010). Prerequisites For Affective Signal Processing (ASP) – Part II. *Proceedings of the Third International Conference on Bio-Inspired Systems and Signal Processing*, 188–193.
- van den Broek, E. L., Janssen, J. H., Westerink, J., & Healey, J. A. (2009). Prerequisites for affective signal processing (ASP). *International Conference on Bio-Inspired Systems and Signal Processing, Biosignals*. INSTICC Press.
- van den Broek, E. L., Janssen, J. H., Zwaag, M., & Healey, J. A. (2010). Prerequisites for Affective Signal Processing (ASP) – Part III. *Proceedings of the Third*

International Conference on Bio-Inspired Systems and Signal Processing, (2010), 432–435.

van den Broek, E. L., Zwaag, M., & Healey, J. A. (2010). Prerequisites for Affective Signal Processing (ASP) – Part IV. *Proceedings of the 1st International Workshop on Bio-inspired Human-Machine Interfaces and Healthcare Applications*, 1, 59–66.

van den Broek, E. L., Zwaag, M., Westerink, J. H. D. M., & Healey, J. A. (2011). Prerequisites for Affective Signal Processing (ASP) Part V - A Response to Comments and Suggestions. *Proceedings of the Third International Conference on Bio-Inspired Systems and Signal Processing*, 301–306.